

Y2K

How much time do you have left?

Don't live in the dark ages...



Take the guess work out of your backup battery system with LINK instrumentation & Freedom 458 Inverter/charger...

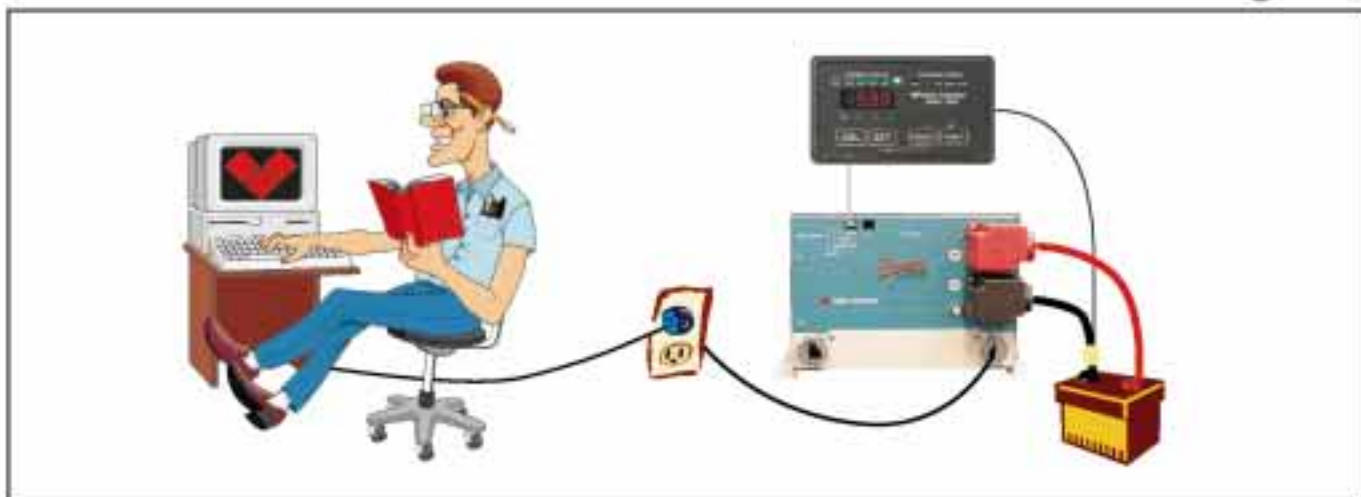

Knowledgeable Customer Service

Call 1-800-446-6180. Email: techhelp@heartinterface.com

Simple Operation

Easy to install. Easy to program. Easy to use.

Integrated Instrumentation

Engineered systems. Designed to work together.

Your time is running out, call Heart Interface today!



heart interface

Heart Interface Corporation · 21440 68th Ave S · Kent, WA 98032
Tel 1-800-446-6180 · Fax 253-872-3412 · www.heartinterface.com



BP SOLAR

BP Solar: we're an advanced solar energy company. We manufacture premium solar modules and we're on the leading edge with new, low cost technologies. But we do much more...

We provide power solutions to enhance your quality of life and we have joined with industry leaders to bring you the best line of renewable energy products available, all backed by a name that is known and trusted throughout the world.

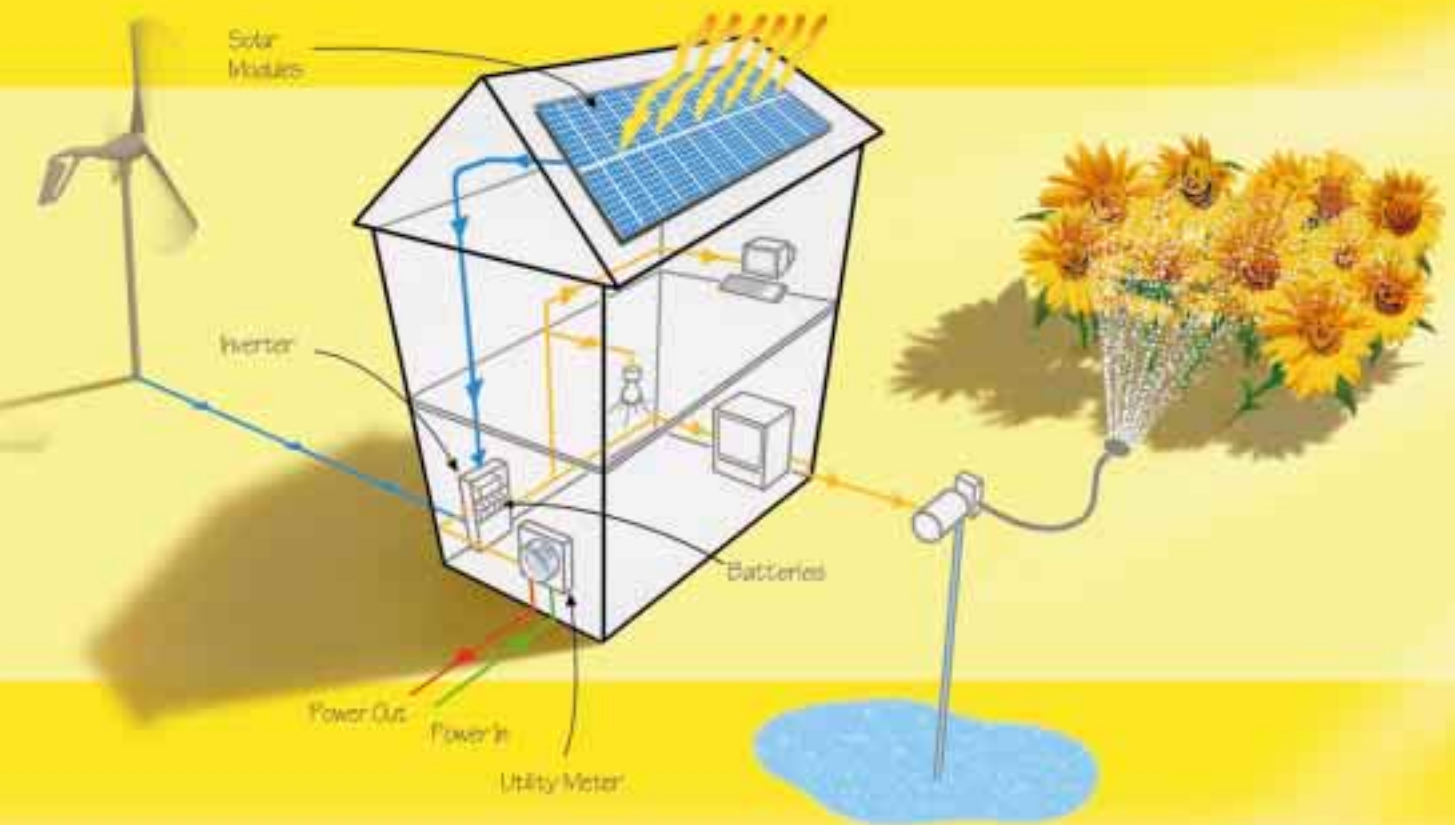

USA:

American Energy Technologies, Ltd. - Florida

Toll Free: 800-874-2190
Phone: 904-284-0552
E-Mail: Solardell@aol.com

Dankoff Solar Products - New Mexico

Toll Free: 888-396-6611
Phone: 505-473-3800
E-mail: pumps@danksolar.com

Alternative Energy Engineering - California

Toll Free: 800-777-6609
Phone: 707-923-2277
E-mail: Energy@alt-energy.com
Internet: www.alt-energy.com

Effective Solar Products - Louisiana

Toll Free: 888-824-0090
Phone: 504-537-0090
E-mail: esp@effectivesolar.com
Internet: www.effectivesolar.com

Alternative Solar Products - California

Toll Free: 800-229-7652
Phone: 909-308-2366
E-mail: mark@alternativesolar.com
Internet: www.alternativesolar.com

Intermountain Solar Technologies - Utah

Toll Free: 800-671-0169
Phone: 801-501-9353
E-mail: utahsolar@aol.com
Internet: www.intermountainsolar.com





BP Solar, the world leader in solar electric systems, provides everything you need in a single package. And trained technicians from your BP Solar dealer can install the whole system in about a day, without disrupting your home or current electrical wiring. The BP Solar Electric Systems use "photovoltaics" or "PV" to convert sunshine directly into electricity. The power feeds into your home's existing electrical circuits energizing lights and appliances. Any extra power flows out to the power grid, actually spinning your utility meter backwards! For more information or the name of a dealer near you, just call one of our trusted partners listed below.

Reliable Technology From An Industry Leader

Business opportunities now available - join our team.



BP SOLAR

CANADA:

Talmage Solar Engineering - Maine

Toll Free: 888-967-5945
Phone: 207-967-5945
E-mail: tse@talmagesolar.com
Internet: www.talmagesolar.com

Powersource Energy Systems - British Columbia

Toll Free: 888-544-2115
Phone: 250-544-2115
E-mail: info@powersourceenergy.com
Internet: www.powersourceenergy.com

Solar Solutions - Manitoba

Toll Free: 800-285-7652
Phone: 204-632-5554
E-mail: solar@solarsolutions.ca
Internet: www.solarsolutions.ca

Powersource Energy Systems - Alberta

Toll Free: 888-544-2115
Phone: 403-291-9039
E-mail: info@powersourceenergy.com
Internet: www.powersourceenergy.com

Trans-Canada - Quebec

Phone: 450-348-4405
E-mail: rozonbatteries@yahoo.com
Internet: www.worldbatteries.com

Powersource Energy Systems - Ontario

Toll Free: 888-544-2115
E-mail: info@powersourceenergy.com
Internet: www.powersourceenergy.com



Southwest Windpower
INCORPORATED
RENEWABLE ENERGY PRODUCTS



HOME POWER

THE HANDS-ON JOURNAL OF HOME-MADE POWER

Issue #73

October / November 1999

Features

- 8 Inverter Converter**
Bill Witt has a history with grid-intertied PV. To make the most of his power company's "time of use" billing strategy, he switched to two separate systems.
- 18 All for Wind & Wind for All**
This neighborhood in Fairfield, Iowa has been off-grid for five years. With the addition of a community wind generator, these four families have filled the gaps in their solar resource.
- 28 Still Crankin' Out Amps**
John Millard wrote up his PV system way back in HP10. Back in those days, everybody was homebrewin' their RE systems. John sees no reason to quit now—his system works just fine. Here's an update.
- 38 More than Just a Bedroom**
Redwood Alliance's workshop is a success again this year. Only this time, the system owners Elias and Gretchen went for the whole house, and intertie too.
- 48 Solar Cooker Followup**
In 1996 Lanseni Niare undertook a quest to take 100 solar cookers to Mali. A year later, he went back to assess their effectiveness, and learned a lot about changing people's habits.



More Features

- 54 Tree Power w/o Chlorophyll**
Even though trees are the ultimate solar collectors, they don't make much electricity. So Mike Caveney decided to put a PV system in his treehouse!
- 58 Laser Groovy**
The high cost of photovoltaics makes every watt count. This new technology (available now) ekes out the highest efficiency yet from all that expensive silicon.
- 74 SolWest Success**
The Northwest gets its own RE fair! Way out in John Day, Oregon, this fair was pretty big for a startup. Heck, with all the solar bozos in town, we almost doubled the population.

GoPower

- 64 Energy Cycle**
Bill Gerosa homebrews an electric bike that really scoots.
- 94 On the Spot**
Shari Prange and Mike Brown do a Voltsrabbitt conversion for the public at the SolWest energy fair.
- 102 Suspend Your Disbelief**
Mike Brown gives the rundown on suspension modifications for EVs.

Cover: Marcus Brown (left) and Mike Sutton (right) haul the PVs to the roof of Elias Elias' (lower left) home. See page 38.

Things that Work!

- 70 MPPT Controller**
RV Power Products' 20 amp charge controller, Solar Boost 2000, gets the Thumbs Up for its 20–30% gain in power output.

Guerrilla Solar

- 84 Guerrilla 0006**
Another Guerrilla surfaces, this one a three year old operation. Solar and wind power are the tools.

Homebrew

- 88 LED there be Light**
Jonathan Scherch builds some simple LED lights. You can too.

Book Review

- 122 The Rammed Earth House**
Green building is RE's missing twin. Check out this book on rammed earth building and learn with us.

More Columns

- 100 Word Power**
"Battery"
- 106 Power Politics**
The California utility deregulation experiment: Learning from our failures.

More Columns

- 110 IPP**
Cut rate gear—friend or foe? Also, RE worldwide.
- 114 Code Corner**
More Grounding. And you too can affect the 2002 NEC.
- 120 To Bee, or Not to Bee**
The bee saga continues.
- 129 The Wizard**
Time, space, and other axes.
- 136 Ozonal Notes**
Global warming, a wake up call. Net metering in OR—the smaller half. And, Richard cools off.

Regulars

- 6 From Us to You**
- 80 HP's Subscription Form**
- 81 Home Power's Biz Page**
- 124 Happenings—RE Events**
- 128 Letters to Home Power**
- 139 Q&A**
- 141 MicroAds**
- 144 Index to Advertisers**

Access and Info

Access Data

Home Power
PO Box 520
Ashland, OR 97520 USA

Editorial and Advertising:
Phone: 530-475-3179
Fax: 530-475-0836

Subscriptions and Back Issues:
800-707-6585 VISA / MC
541-512-0201 Outside USA

Internet Email:
hp@homepower.com

World Wide Web:
www.homepower.com

Paper and Ink Data

Cover paper is 50% recycled (10% postconsumer / 40% preconsumer) Recovery Gloss from S.D. Warren Paper Company.

Interior paper is 50% recycled (50% postconsumer) RePrint Web, 60# elemental chlorine free, from Stora Dalum, Odense, Denmark.

Printed using low VOC vegetable based inks.

Printed by

St. Croix Press, Inc.,
New Richmond, Wisconsin

Legal

Home Power (ISSN 1050-2416) is published bi-monthly for \$22.50 per year at PO Box 520, Ashland, OR 97520. International surface subscription for \$30 U.S. periodicals postage paid at Ashland, OR, and at additional mailing offices. POSTMASTER send address corrections to Home Power, PO Box 520, Ashland, OR 97520.

Copyright ©1999 Home Power, Inc.

All rights reserved. Contents may not be reprinted or otherwise reproduced without written permission.

While *Home Power* magazine strives for clarity and accuracy, we assume no responsibility or liability for the use of this information.



Recycled Paper



Recyclable Paper

People

Joy Anderson
Mike Brown
Sam Coleman
Richard Engel
Lawrence A. Gamble
William A. Gerosa
Anita Jarmann
Kathleen Jarschke-Schultze
Jim Kerbel
Stan Krute
Don Kulha
Don Lowebug
John Millard
Lanseni Niare
Christine Parra
Karen Perez
Richard Perez
John Perlin
Shari Prange
Benjamin Root
Jonathan Scherch
Joe Schwartz
Wade Webb
Michael Welch
John Wiles
Dave Wilmeth
Myna Wilson
Bill Witt
Ian Woofenden

“Think about it...”

Quantum mechanics—
The dreams
stuff is made of.

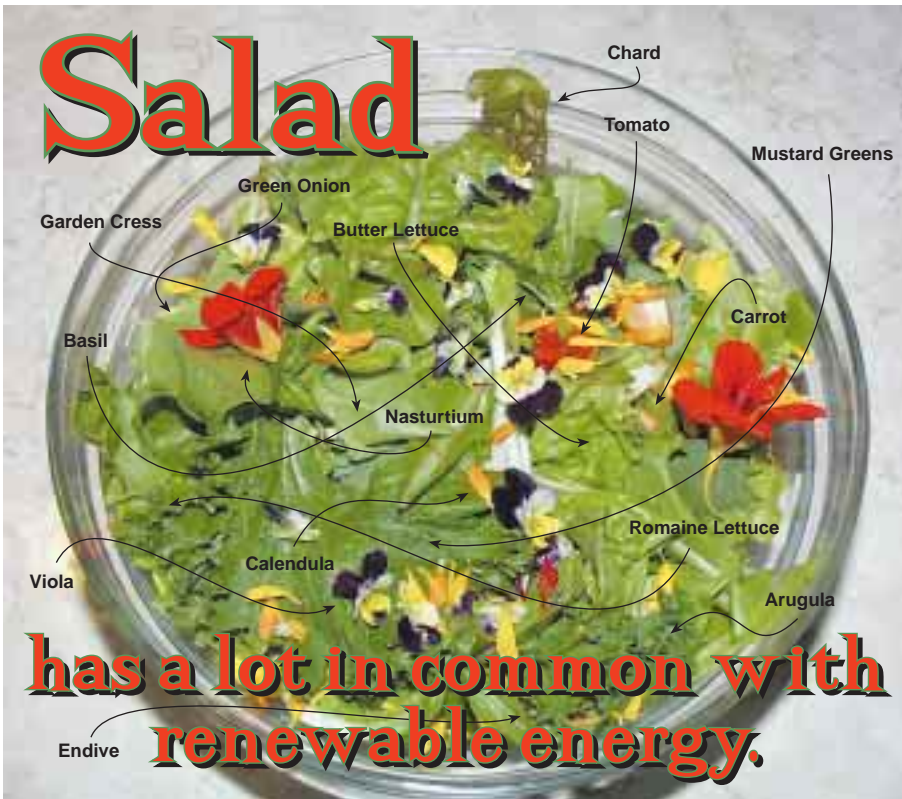

The same sun that grows vegetables also powers renewable energy systems. The same backyard where the veggies grow is also used to make energy. The veggies in the salad are nourished by water pumped with solar energy.

Every time I eat salad, I marvel at the versatile and generous gift of sunlight. What a winner. Sunlight grows our food, heats our homes, and powers our lives—and it's delivered free daily.

—Richard Perez

Richard harvests sunshine.



Karen harvests sunshine.



Power Now



 **SolarSense.com**
1-877-79-SOLAR

System Evolution: A Parade of Inverters

Bill Witt, with Jim Kerbel

©1999 Bill Witt

After years of searching, I located my land along the Wisconsin River in 1989. It was mostly water, a few islands, and tangles of forested wetlands and swamp. But there were also a few acres of high land, which held a collapsed toolshed, creaky woodshed, and a century-old clapboard farmhouse in sad disrepair.

The house had pine plank floors with paths of the decades worn in them. It had nine foot (2.7 m) ceilings, rough old plaster, a narrow, creaking stairway to a moldering attic, and a dank fieldstone cellar complete with grave markers dating from the turn of the century, half buried in the dirt.

Disconnected

Two years later the house was cleaned out, at least to the point where it didn't sicken me, but otherwise my estate was more or less unchanged and I was enjoying it very much. One stormy day, a tree branch knocked out the power line to the house, and my power supply hasn't been the same since.

Bob Ramlow of Snowbelt Solar, in Amherst, Wisconsin, referred me to Jim Kerbel and his Photovoltaic Systems Company for the design and installation of my system. At that time, Bob insisted on a 24 VDC system for economy of wiring and efficiency of operation. "It has the force to punch through your existing wiring, so you won't have to re-wire the whole house." In fact, most rooms had been jerry-rigged by a half century of renters. There were nests of 120 VAC cords of sundry gauges snaking along ceilings and walls, all tied to a 30 amp service in what was then a filthy clothes closet.

First System

Jim placed a 12 foot (3.7 m) steel mast 5 feet (1.5 m) down in a clearing on a sandy knoll about 100 feet (30 m) from the house. Using a trencher, he ran 6 gauge (13 mm²) wire underground to a battery pack consisting of eight 12 V 105 AH deep cycle lead-acid batteries. We put the batteries in a convenient spot under the kitchen counter, where I thought they would be sheltered as much as possible in summer and winter.

The mast supported a passive Zomeworks six panel single-axis tracker. We installed two 60 watt Solarex panels on it, which was all I could afford at the time. Jim built a power center with a small Sun Selector M8 charger, six breakers, and gauges showing solar input, load, array amps, and battery voltage. A 600 watt Heart inverter provided sufficient 120 VAC power for my simple needs at the time.

The tracker moved 180 degrees east to west during the day. In spring, summer, and fall, I set it at one of the three available locking south-facing angles. It worked well and I was happy with it even though it was slow to warm up and orient eastward in the mornings. What I particularly liked was the fact that it required no electricity for its movement. It just sat out there on the knoll all by itself in the heat and cold, doing its job.

I went around the house putting in 24 VDC ballasts and high efficiency fluorescent lighting in all the rooms.



Bill's shop, with two Wattsun dual-axis trackers which hold thirty-four Solarex MSX-64 PV panels for two independent systems.

Altogether, this first system served me well for two years, and I plan to use the power center and inverter on my camping van.

Time for an Upgrade

In 1991 I was ready to expand. Jim and I met several times with Tom Stafford, engineer for the local utility, Wisconsin Public Service Corp., to design a grid intertie system. Jim was careful to go over every detail, and Tom was very open-minded and receptive. This was uncharted territory for our region, which held no intertie systems to date. Each of them met repeatedly with me and with each other. The success of the project was due to their continued dedication. I think I was lucky to get the right people in the right place at the right time.

These projects are expensive and complex and not to be taken lightly. It would have been even better to have obtained grant money, discounts, or tax credits, but there was nothing available. The first small system cost about US\$3,000, and the subsequent two about US\$18,000 to \$20,000 each.

Over a period of roughly half a year, all preliminary understandings with the power company had been reached and described in a thick contract which Tom and I signed. I obtained a building permit from Portage County after furnishing a hand-drawn site map. It was drawn to scale and showed all structures and the proposed tracker, which was to be at the west end of a steel pole building I had just erected. The permit cost was a nominal US\$20.

The utility had been most concerned about matching its 60 Hz cycle to my inverter's output, and with automatic shutdown to insure the safety of repair workers in case

Stand-Alone System

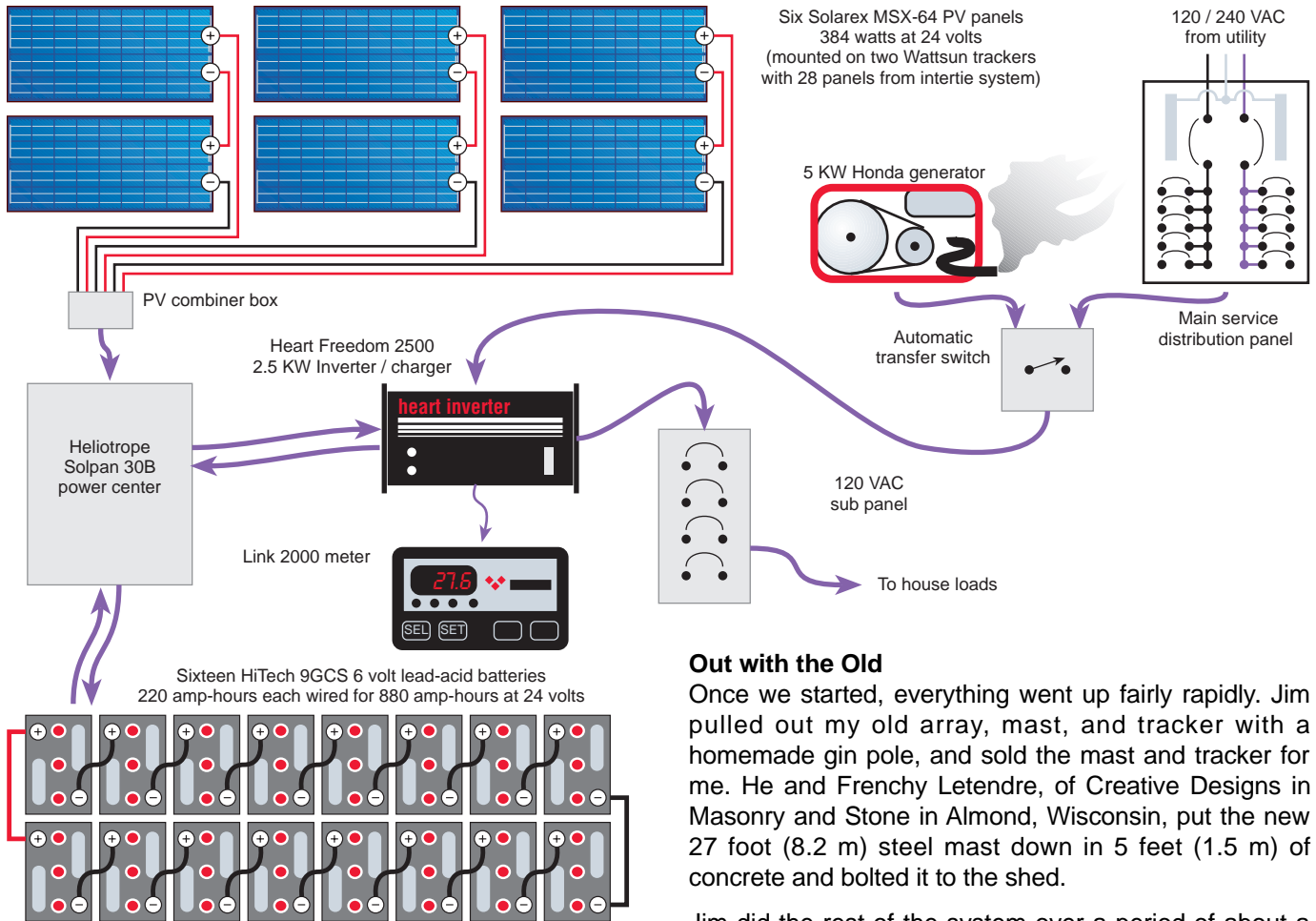

of line failure in the area. Jim won their confidence on both counts.

I had the utility put about 100 feet (30 m) of underground cable in from their power pole to my shed. The lead portion runs under the road in front of my house, and the remainder is under my driveway, ending at the utility meters on my shed. It cost about US\$2 a foot plus extras for drilling under the road—well worth it to have my sky free of overhead wires.

Since I am on time-of-day metering (two functions: on-peak at 11 cents/KWH and off-peak at 3 cents/KWH), and buy and sell mode (two more functions), two meters are required. By law, Wisconsin has an optional time-of-day price differential which enables buying low and selling high if you can restrict your heavy usage to the evening hours. Time-of-day pricing is certainly the exception rather than the rule in the U.S. at present. I know that at his home and office system, Jim charges up his batteries and equipment at night and sells during the day, and is very pleased with the situation.

Out with the Old

Once we started, everything went up fairly rapidly. Jim pulled out my old array, mast, and tracker with a homemade gin pole, and sold the mast and tracker for me. He and Frenchy Letendre, of Creative Designs in Masonry and Stone in Almond, Wisconsin, put the new 27 foot (8.2 m) steel mast down in 5 feet (1.5 m) of concrete and bolted it to the shed.

Jim did the rest of the system over a period of about a month. Carl Hansen helped and also rewired my old farmhouse properly for 120 VAC. When completed, there were sixteen 64 watt Solarex panels on a Wattsun dual-axis tracker tied to a Trace SW4024 charger/inverter.

Two short lengths of 4/0 (107 mm²) cable lead to an insulated wooden box nearby, housing sixteen 6 volt 220 AH deep cycle lead-acid batteries. The 24 VDC system has four sets of batteries wired in parallel, with each set of four wired in series. This provides total storage of 21.1 KWH (24 V x 4 x 220 AH = 21,120 WH).

The Trace inverter kept the batteries charged (bulk 28.8 V, float 25.2 V), sold all excess power to the grid, and bought it when needed for extra battery charging or supplying my house. Unfortunately, it supplied 120 VAC house power from the grid continuously. So Jim added a timer, power contactor, and UPC-1 set point controller for time of use. The only time the Trace was on grid was if two parameters were met: the batteries were full, and it was during peak selling hours (9 AM to 8 PM). This change did improve system performance.

We also had a manual override so we could back up the system with cheap off-peak power (8 PM to 9 AM). This allowed inverting off the batteries in the evenings, when I used most of my loads. The Trace then bulked up the batteries the next morning from PV if it was a bright day, or from the grid if it wasn't.

Limitations

The problem here is that the Trace is built to maintain batteries strictly as emergency backup. But since I didn't really want to use the batteries in this way (there is also a Honda generator for backup), the timer was a stopgap measure that was somewhat awkward but necessary to allow regular evening use of battery power.

Unless disconnected by the timer (or grid power failure), the Trace always draws load power from the grid. This was the crux of the problem, which necessitated the timer in the first place. It is a very annoying limitation of the Trace, because I wanted to draw load only from the batteries.

It would be very nice to be able to program the Trace to draw load power from a designated source or combination—batteries and/or grid—at the option of the user. I wanted to draw only from the batteries while still selling to the grid, but the Trace will not do this. I don't see why Trace can't fairly easily revise their software to accommodate people like me. But perhaps there is little demand for such systems and therefore little incentive for such a revision.

Grid Intertie System

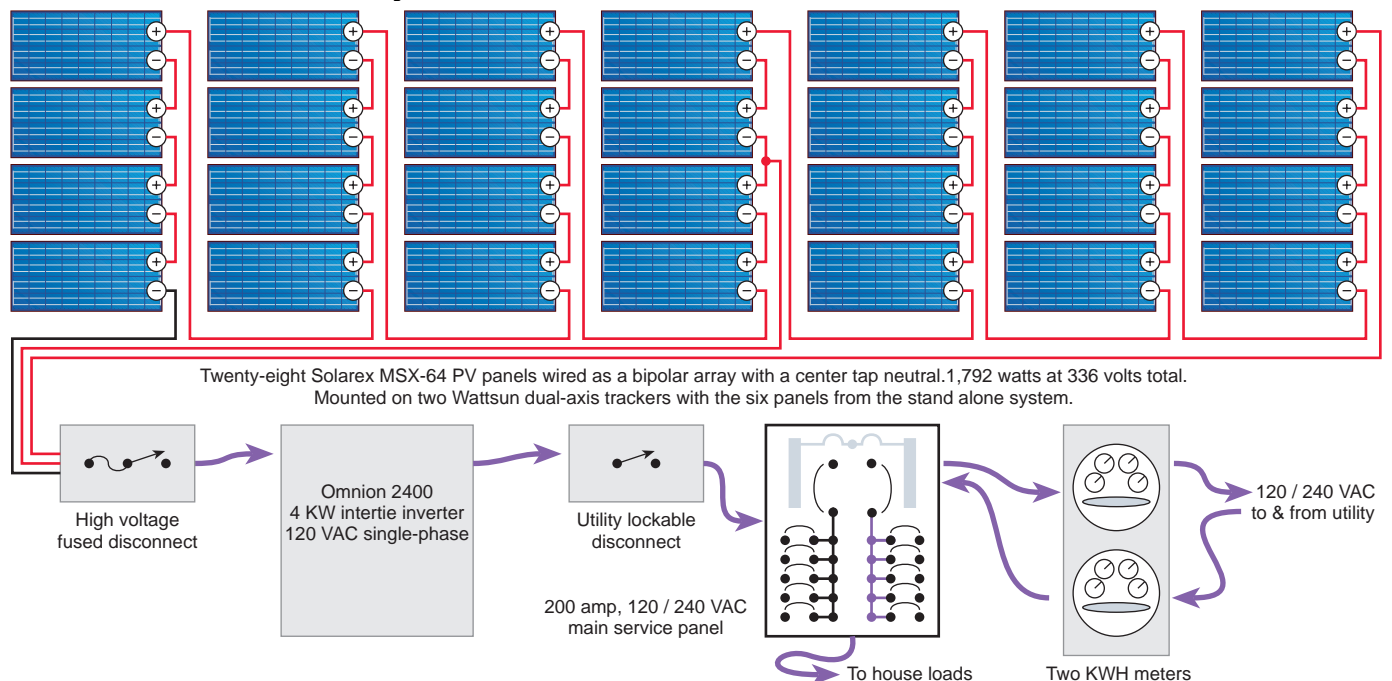

All Things to All People

The Trace is an interesting piece of equipment, multitasking between its various jobs, and that was also one of the problems for me. It spent a lot of time fussing over the batteries—a fairly large-capacity bank in my case—which was all downtime from grid sales. I could not draw solely upon the battery pack for house power outside the limits of our timer, as the Trace is presently designed. So during the day, my usage all came from the grid when I'd rather have been selling to it. The Trace bulks up the batteries, sells from them to the grid down to float level, and then bulks them up again, which uses up a lot of inverter time.

In general, I guess the problem is that the Trace can't be all things to all people. And it does a good job at grid buy/sell intertie while maintaining a battery pack strictly as an emergency power source should the grid go down. But it loses a good bit in grid sales by taking tender loving care of the batteries, bulking up quite often and spending substantial portions of every hour switching between sell, bulk, and float modes.

Stubborn Old House

The AC power to my house goes underground about 100 feet (30 m) from the shed to the house via 2/0 (67 mm²) aluminum cable to a 200 amp service in the cellar. Jim broke a big drill bit and used up half a day getting through two thicknesses of 8 by 8 inch (20 x 20 cm) foundation timbers. He was not very happy about it, but that's old houses for you—stubborn, never easy, and full of surprises, mostly not good. Carl also fought



Bill's two systems converge, but remain discrete, on the power wall in his shop.



Safety lockout and two KWH meters for the intertie system.

to get wiring for a battery voltmeter and DC nightlight in the dining room up from the service box and into the wall through the huge foundation.

There are lightning arrestors in all appropriate places throughout the system. The tracker, mast, grid, and house services are grounded by 8 foot (2.4 m) ground rods. All ground wiring is continuous, unbroken from origin on the equipment to terminus on the copper ground rod. Jim is a very thorough craftsman.

Production

The theoretical maximum production of the system was about 1 KW (16 panels at 64 W each = 1.024 KW). Wisconsin has about 3.85 average sun hours per day, according to the University of Wisconsin Solar Energy Lab. So at 100 percent efficiency, the system theoretically could average 3.85 KWH per day. I calculated averages for over two years from my utility bills, which include total on-peak and off-peak sales. The average annual output is about 2.4 KWH per day—an actual efficiency of 62 percent.

Besides matters of variations in annual rainfall and cloudiness, and site exposure to the sun, there are various system losses to be expected under field conditions. For example, while solar panel production goes up in cold weather, my battery efficiency goes down because temperatures are only 10 to 20°F (6-11°C) higher inside the battery box than outside, even though it is insulated. In summer it sometimes rises to

90°F (32°C) or more in the box, which also cuts down battery storage capacity. But I think the main factor is that the Trace had to spend lots of energy frequently topping off the batteries, and this decreased sales significantly.

I am trying to design a passive solar system to keep the batteries warmer in winter, and a better ventilation system for summer. The batteries are located in my unheated shed, and though it incorporates some passive solar features, more must be done to moderate temperature extremes.

Here's the Bill

The utility levies a monthly service fee of US\$8.50 (recently raised to \$9.50). Since I failed to sell back this much in electricity, the bill was usually a debit rather than a credit. I wrote a letter of protest to utility president Larry Weyers in the Green Bay, Wisconsin headquarters, requesting a fee waiver. He turned the matter over to Tom Stafford. The utility obviously had no intention of granting my request, in spite of my protest that it costs me money to sell them electricity.

In fairness, Tom pointed out that it also costs them money to maintain equipment, transmission lines, and meters on my shed. But it still seems petty and wrongheaded to refuse to give me a small token break to acknowledge and encourage energy conservation and production.

Final Upgrade

In June 1998, I attended two PV workshops offered by the Midwest Renewable Energy Association (MREA) in Amherst, Wisconsin. They were taught by Jim, and by Chris LaForge of Great Northern Solar. Afterwards I decided to put up another tracker and enlarge my setup.

We had studied an Omnion system in the workshop, and in the fall I decided on this particular inverter because of its high efficiency. Jim said that according to his calculations, the Trace unit was selling back to the grid at somewhat over 80 percent efficiency, while his Omnion system attained about 94 percent efficiency.

Jim re-sold the Trace inverter to a customer with a stand-alone system. We decided that the answer to my particular problem was *two* systems—a batteryless grid sell-back system using the Omnion inverter, and a stand-alone system using a new Heart Interface Freedom 2500 charger/inverter.

Jim put another mast on the opposite end of the shed for a second tracker, with an array of 18 Solarex panels. The new grid-tie system consists of an Omnion 4 KW 2400 series inverter with two 14 panel sub-arrays, for a total of 28 panels selling exclusively to the grid. A total

Sixteen HiTech batteries and their insulated box.



Omnion Photovoltaic Power Converter

The Omnion Photovoltaic Power Converter is a high efficiency grid-interactive *non-battery based*, fully automated, user-friendly system. Most Americans who live on the grid don't want to deal with batteries. The best choice for these folks is to use the utility grid as their battery. You don't have to replace it, water it, or clean it.

The Omnion unit we used in the Witt system includes these standard features:

- Peak power point tracking
- GFCI for roof-mounted PV
- High voltage PV wiring for lower cost
- Morning auto start and evening auto off
- Over/under voltage protection
- Over/under frequency protection
- Over temperature and islanding protection
- No buttons to push or program—totally automatic

As a system installer/designer, I own one of these units and find that it gives better performance from my PV system than any other inverter/charger available. I am in my twentieth year as a systems designer/installer, and this is my first choice. But my customers usually don't see it that way. They often want a battery backup.

If you want a battery backup, this is not the inverter for you. And you must invest in PVs at least 12 modules at a time to provide the necessary peak voltage. This means the minimum system cost is about US\$10,000. But beyond that, it's hard for me to find any disadvantages to this system.

With the Omnion system, your PVs are wired for high voltage DC at or just above peak grid voltage. So the inverter simply converts the high voltage DC to grid-compatible AC using high speed electronic controls. There is no transformer to waste your PV power.

A typical Omnion 2 KW system costs four to six thousand dollars less than any battery system of comparable size. This is a high reliability piece of equipment and it delivers more watt-hours of clean electricity to the grid for your system dollar. What more could you ask for?

—Jim Kerbel

of 6 panels with a separate Heart Freedom 2500 charger/inverter system are tied through a Solpan 30B power center to my present battery pack, dedicated exclusively to my home. We trenched in another cable and installed a Link 2000 remote control on a wall in the old house.

The two systems are completely separate and wired independently. The Heart is tied to two panels on my first sixteen panel array and to four on the new eighteen panel array, leaving fourteen panels free on each array for each leg of the Omnion system. These independent systems, one for the grid and one for the house, sharing arrays, constitute a unique setup, I think.

The Heart, operating alone, is more efficient at its single dedicated task than was the multitasking Trace, maintaining the batteries at a peak level of 28.8 VDC rather than having them constantly bulking up and floating down.

For backup I still have the generator, and ultimately also the grid. Jim incorporated the timer which can be activated and set manually to charge the batteries from the grid (if necessary) during off-peak hours when it is far cheaper.

Modified Wave Problems

There are some problems in house power caused by the simpler modified waveform inverter versus the smoother stepped-wave output of the former Trace SW4024.

One major problem set me back \$US500 because I had to replace a 1/2 hp 120 VAC deep well pump motor and control. The old one, which worked perfectly with the Trace, would not function properly with the Heart. The pump controller was down with the pump. Jim said this is bad news for modified wave inverters, and he always recommends above-ground pump controllers.

Also, I had purchased outdoor motion-sensor lights, but they won't work with the Heart either. Finally, one brand of high efficiency fluorescent lights, Sylvania, began to flicker badly and had to be replaced. Other brands, including Osram and Abco, have worked well.

Credits, Not Debits

The Omnion intertie system can produce a theoretical maximum of about 1.8 KW (28 panels at 64 W each = 1.792 KW). This translates to an average annual maximum of about 6.9 KWH per day (1.8 KW x 3.85 hours).

In the first eight months of operation, from November 1998 to July 1999, the system has produced an average of 6.3 KWH per day. This is very close to the maximum of 6.9 KWH—an efficiency of 91 percent, with the sunniest summer months still to come.

So it is fulfilling our highest expectations to date, and it is very satisfying to listen to the high-pitched whine of the Omnion inverter going full tilt on a bright sunlit day. And now my utility bills are credits rather than debits, so the Omnion can go right on singing my song for the foreseeable future.

Access

Author: Bill Witt, 601 W. Casimir Rd., Stevens Point, WI 54481 • 715-341-4162 • wwitt@uwsp.edu

System Design and Installation: Jim Kerbel, Photovoltaic Systems Co., 7910 Hwy 54, Amherst, WI 54406 • 715-824-2069

Heart Interface Corp., 21440 68th Ave. S., Kent, WA 98032 • 800-466-6180 or 253-872-3412

Fax: 253-872-3412 • sales@heartinterface.com
www.heartinterface.com

Trace Engineering, Inc., 5916 195th NE, Arlington, WA 98223 • 360-435-8826 • Fax: 360-435-2229
inverters@traceengineering.com
www.traceengineering.com

Omnion Power Engineering Corp., PO Box 879, East Troy, WI 53120 • 414-642-7200 • Fax: 414-642-7760
hmeyer@omnion.com • www.omnion.com



MORNINGSTAR

BREITLING

Powered Around the World...

...by PROSTAR
The World's Leading Solar Controller

MORNINGSTAR CORPORATION Phone: 215-321-4457 • Fax: 215-321-4458
Website: www.morningstarcorp.com
1098 Washington Crossing Rd., Washington Crossing, PA 18977 USA

**“MY MOM LOVES TO WATCH
THE POWER METER SPIN
BACKWARDS.
I JUST THINK
THAT WIND
THING IS
REALLY
COOL.”**

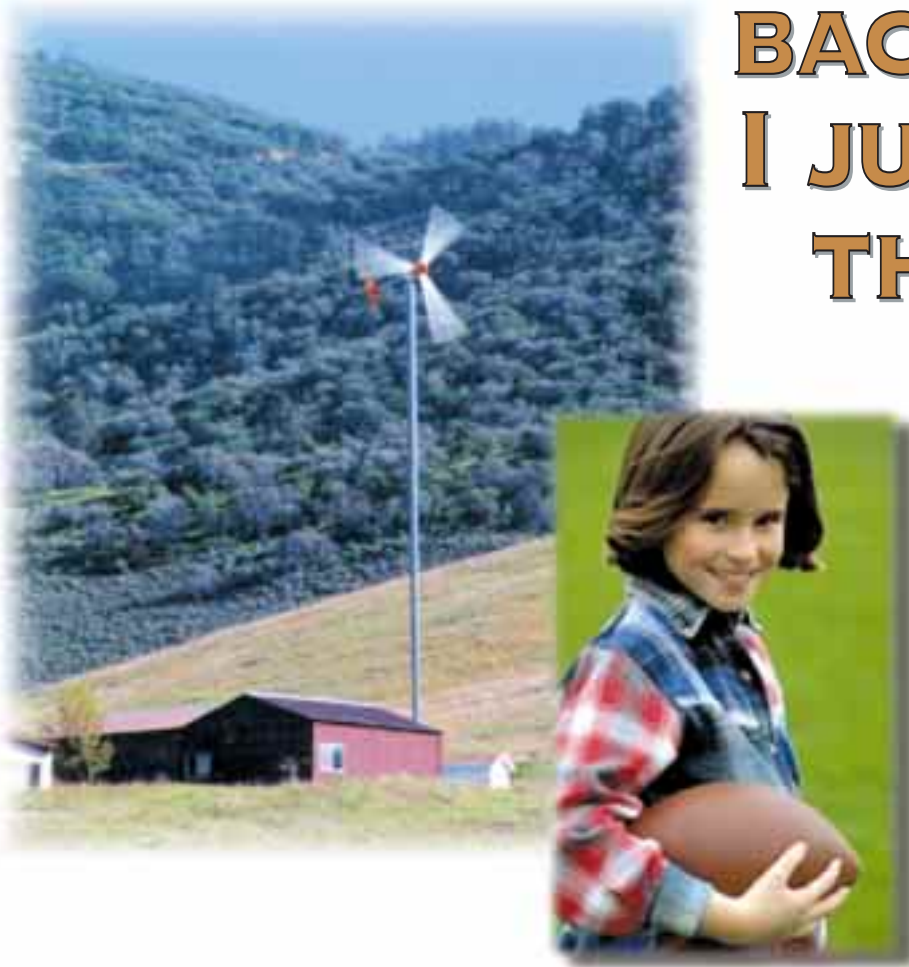

**A 10 kW Bergey Excel
wind turbine system
can reduce your utility
bills by up to 90%.**



**BUT, WILL IT WORK
FOR ME?**

**GET ANSWERS, 24 HOURS A DAY,
AT WWW.BERGEY.COM OR CALL
TOLL FREE 1-888-669-6178,
8 AM – 6 PM, CST**

For nearly twenty years Bergey WindPower has been America's leading supplier of wind energy systems for rural homes*, farms, and small businesses. This year we are introducing our exclusive 5-year warranty and our advanced UL-certified GridTek 10 inverter. Whether you want a total installation from a certified Bergey dealer or you want to save money by installing it yourself, Bergey WindPower can help you to power your dream with the power of the wind.

*Property size of at least one acre is recommended.



SIMPLICITY • RELIABILITY • PERFORMANCE

**2001 PRIESTLEY AVE.
NORMAN, OK 73069
T: 405-364-4212
F: 405-364-2078
SALES@BERGEY.COM
WWW.BERGEY.COM**



Tom Bishop



Dan Healy



Julie Collett



Corey Johnson



Nick Mariana

Great People... Great Service...

Free to
Home Power
Readers!

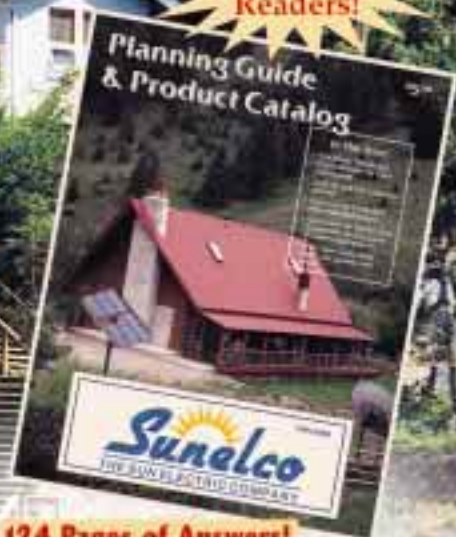

124 Pages of Answers!

Our publication begins with basic load analysis and sizing information and includes case histories, design guidelines and useful in-depth data required for system layout. It offers detailed descriptions of solar components and packages. A must for every energy library!

At Sunelco we pride ourselves on the quality of our performance and the integrity of our Systems Designs. Because we are a part of the Kyocera Solar team we can offer you the finest that the Solar Industry has to offer

- The highest quality solar modules in the industry.
- The best warranty in the industry... **25 years!**
- The largest inventory of modules and Balance of System components available.
- People you can trust - Talented, professional and courteous.
- We live with the products we sell.
- 24 hour shipping on in-stock merchandise.

What this means to you is
Small Company Service — Big Company Guarantee!

Sunelco

THE SUN ELECTRIC COMPANY

A DIVISION OF KYOCERA SOLAR

100 Skeels Street • P.O. Box 787 • Hamilton, MT 59840

Shop On-line at: www.sunelco.com

1-800-338-6844



Trace Engineering

full page
four color
on negatives

This is page 17

Sharing the Wind

Fairfield Neighborhood Wind Project

Lawrence A. Gamble

©1999 Lawrence A. Gamble

Tilting the 40 foot “temporary” tower upright with the 3,000 watt Whisper wind genny in place.

The wind blows, the sun shines. Many dream of using the sun and wind to provide energy for their homes. In Fairfield, Iowa, people are making this dream a reality.

Fairfield is home to Maharishi International University and about 4,000 people who do transcendental meditation, among other things. Several thousand people get together to meditate twice a day in two large domes. We experience a deep silence and connection with natural law during meditation. This translates into a deep interest in living in tune with natural law, in ways that do not harm the earth or ourselves.

Fairfield is a hotbed of natural building and renewable energy (RE) activity. There are 25 to 30 RE-powered homes in this small southeastern Iowa town of 10,000. Visitors are welcome almost anytime, and internships are available for people who would like to learn about sustainable agriculture, energy, or housing projects.

Solar Neighborhood Adds Wind

For the last five years, my neighborhood in Fairfield has been getting all of its electricity directly from the sun, using photovoltaic (PV) panels. Photovoltaics is a bit

like magic—sunlight is converted directly into electricity, with no moving parts and nothing to wear out. In contrast, 99 percent of the electricity supplied by electric utility companies in Iowa comes from coal, oil, and nuclear power.

We’ve now taken an exciting new step in my neighborhood—the installation of a shared wind generator to supplement the power obtained from our solar panels.

The Sun and Wind in Iowa

Iowa is truly blessed with an abundance of renewable resources. We have sun, wind, biomass, and even falling water in some places (of course, these seemingly separate energies all have the same source—the sun). It’s obvious to anyone who has spent any time in Iowa that if the sun isn’t shining, often the wind is blowing. The combination of sun and wind here can provide an abundance of energy, whether you look at shorter daily and weekly weather cycles or at longer seasonal cycles.

Over the last five years, the homes in my neighborhood have demonstrated the joy of getting by comfortably on solar energy. Many times during the year, we have an overabundance of energy. And once in a great while (usually less than one percent of the time), we run a

little short. Then we have to conserve a bit, or run a small backup generator. This year we've discovered that when you supplement solar electric generation with wind power, the result is the bliss of a real abundance of energy.

Two Curves

To confirm this intuition and informal observation about the complementary nature of the sun and wind in Iowa, I obtained daily sun and wind data from the airports at Ottumwa and Burlington. The result is graphed to the right.

The important thing about these graphs is not the exact value at any point, but the shape of the two curves. As expected, the amount of energy available from the sun has a peak in the summer months and a minimum in the winter months. The wind has a peak in the winter months and a minimum in the summer months. As you can see from the shape of these two curves, the wind and sun are complementary; the peak for one is the minimum for the other. Combine the two and it's easy to have an abundant source of energy year-round.

Four Solar Homes

My neighborhood is in a new subdivision, which does not have utility power or water available. There are now four households—Gamble, LaFrancis, Munson and Wright—all of which have obtained their electricity from solar power for the last five years. Two homes have their own solar electric systems. The other two homes share a single system. Ultimately, all four homes will probably have independent solar electric systems.

My system has 1,140 watts of PV, configured for 24 volts. There are six groups of seven Carrizo laminate PV modules, a Trace 2624 quasi sine wave inverter, and twelve 6 volt, 220 amp-hour Exide batteries. I have a Power Pulse desulfation system and a Bobier Electronics OmniMeter.

My appliances include a Sun Frost RF-12 refrigerator, 30 inch (76 cm) TV, stereo, compact fluorescent lights, and computers. I also have a water pump and a large variety of tools (drill press, bench sander, radial arm saw, worm drive skill saw, drills, belt sanders, etc.).

I also run the LaFrancis house, which is about 500 feet (150 m) away. They are connected by a #10 (5.3 mm²) wire to the AC output of the inverter, and have lights, TV, stereo, and two compact refrigerators.

Seasonal Resource Comparison

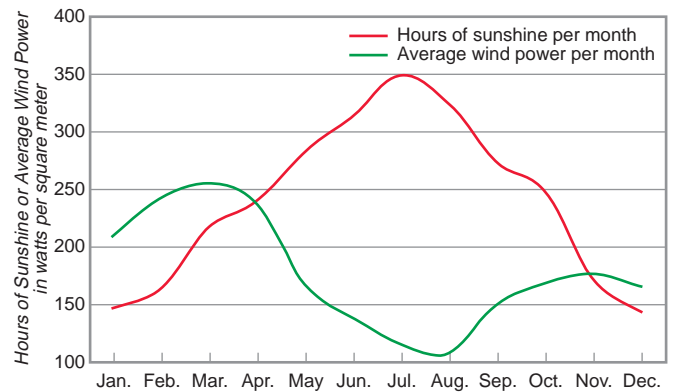

The Munsons have 760 watts of PV, also at 24 volts. They have four groups of seven Carrizo laminate PV modules, a Trace 2624 quasi sine wave inverter, and a Cruising Equipment Amp Hour +2 meter. They also have twelve 6 volt, 220 amp-hour Exide batteries and a Power Pulse desulfation system. Their appliances include an apartment-sized refrigerator, compact fluorescent lighting, and other standard appliances, plus a mini-dish TV system.

Max Wright is out of town for a year, and we haven't connected the wind generator to his system, although we will when he returns. His system is also at 24 volts, and he has 760 watts of PV. He has four groups of seven Carrizo laminate PV modules, a Trace 4024 sine wave inverter, and four 6 volt, 220 amp-hour Exide batteries.

The Wind System

In 1997, my neighbors and I got together and decided to install a wind generator that we could all share. After much thought, I recommended a Whisper 3000 (3,000

A boom truck was used to tilt 'er up.





Lonnie Gamble in his battery room, with the Whisper controller visible in the left rear.

watts, 24 volts, and a 15 foot (4.6 m) diameter rotor). Much thanks to Elliot Bayly at World Power Technologies for helping think the system design through. My neighbors and I shared the US\$4,000 cost of the machine.

With the machine chosen, the next step was to pick the spot for the wind generator tower, and to size the wires going to each battery bank. To minimize cost, and losses in the wire, it was essential to pick a central location. The location we chose is less than 300 feet (90 m) from each house.

The three-phase AC power from the Whisper is changed to DC by a device called a rectifier. Rectifiers use diodes (one of the most simple electronic devices), which are like a one-way valve for electricity. They let electricity flow in one direction but not in the other. In our system, the diodes perform an additional trick. In addition to changing AC to DC, they allow power to flow from the wind generator to each battery bank, but they block the flow of power from one battery bank to another.

We have a separate rectifier at each battery bank. The rectifiers isolate the battery banks from each other, keeping each battery bank from draining or charging the others. The power from the wind generator automatically flows to the battery bank with the lowest voltage. When all battery banks are full, the controller turns on a large resistive load that comes with the Whisper 3000 and absorbs all the excess power.

I initially thought that we would have to use a higher voltage model and a transformer at each location. It turned out to be cheaper to use the lower voltage

model, and to use larger wire to each battery bank rather than using transformers. We ended up with three #0 (53 mm²) cables to my location and three #00 cables to the Munsons (#00 (67 mm²) cable is about 1/2 inch (13 mm) in diameter—this is big, heavy wire!).

Controlling the Wind Generator

With PV, when the batteries are full, you can simply disconnect the panels. With a wind generator, some method must be used to control the machine if the batteries are full and the wind continues to blow. If the wind generator is allowed to turn in the wind without a load, it will overspeed and may damage components.

There are three methods for controlling wind generators: keeping some kind of electrical load on the system, mechanically spilling wind from the blades, and using a brake to stop the machine. World Power's Whisper machines do all three. Their machines are regulated by a controller that can connect a resistive load large enough to take the full load of the generator if the batteries are full.

The Whisper also controls output in high winds by tipping the blades back to a horizontal position. In high winds it looks a more like a helicopter than a wind generator. This is necessary because the power available in wind is related to the wind speed cubed—double the wind speed and you get eight times the power. The energy available in a 40 mile per hour (18 m/s) wind is 64 times greater than the energy available in a 10 mile per hour (4.5 m/s) wind. The Whisper simply spills this extra energy by tipping back the blades, a technique that has been used to govern wind generators since at least the 1930s.

As a final safety measure, shorting all the leads of the generator together can shut down the Whisper. This puts a huge load on the generator and keeps it from starting up. The down side of this method of stopping the generator is that it is not always successful in high winds.

Managing a Shared Resource

The controller and dump load for the wind generator are located at my house. There are shut-off switches (which simply short out the three-phase AC coming in from the generator) located at the Munson house, the tower base, and at my house. If a storm is coming, or there is some reason to shut off the machine, any of us can do it. I generally watch and manage the wind machine. If all our battery banks are full, we usually shut the wind machine off.

I usually check with the Munsons to make sure that their batteries are also full before shutting the wind machine off. It turns out that I am a larger power user

than they are and that if my batteries are full, most likely their batteries are full too. In cold weather, I sometimes let the machine run just to get the extra heat. We have extra energy about 70 percent of the time.

I own the wind generator. The Munsons had a well drilled, and I get access to the well in exchange for them getting access to the wind generator. I was initially more worried about the social issues than the technical issues with this shared system, but everything seems to be working smoothly.

The LaFrancises (the people connected to my system with a 500 foot (150 m) AC extension cord) also watch the wind machine. If there is going to be bad weather and no one is around, they can shut the machine off at the base of the tower. They don't currently have a way to monitor the battery voltage at their house, so they are not usually involved in shutting the machine off if the batteries are full.

Nelson LaFrancis designed and built the tower. He also has a truck with a crane rig that we can use to safely raise and lower the tower. We all share in the duties involved in operating the wind system, and it works out pretty well.

Power On High

We had to choose a tower design. You can increase annual output of a wind generator by increasing tower height. Due to friction of air moving across the ground, wind speed increases with height above the ground. It's pretty easy to go up another 20 feet (6 m) or so and get another couple of miles per hour of wind speed. Because the power in the wind is related to the wind speed cubed, there is almost twice as much energy available in a 12 mph (5.3 m/s) wind as there is in a 10 mph (4.5 m/s) wind.

Also, it's important to be above turbulence created by the wind flowing around trees and houses on the ground. There is a lot less wear and tear on the machine if it operates in smooth air. Picture water flowing and swirling across the landscape, around trees and buildings, and you get an idea of what wind turbulence looks like.

Typically, the optimum height is 80 to 100 feet (24–30 m) above the ground. Our location is on top of a hill. I felt that 60 feet (18 m) was a minimum, and our tower



Lonnie cranking the tower up from the back of Nelson's boom truck.

should ideally be 80 feet (24 m) tall. We ruled out a guyed tower because the guy wires would take up too much space, and we didn't want to look at them. We wanted a tower that would tilt down for installation and repair.

Temporary Tower

Nelson LaFrancis is a genius metal fabricator, so we left the design and fabrication of the tower to him. The tower is by far the most complicated and difficult part of the whole installation. While we were planning for the permanent tower, we put the wind generator on a temporary tower 40 feet (12 m) tall made of 5 inch (13 cm) schedule 40 steel pipe.

We installed the foundation for the permanent three-legged tower. The footings for each leg have five yards (15,000 pounds or 6,800 kg) of concrete in the foundation. Each footing is on the corner of an 18 foot (5.5 m) triangle. My neighbor Bill Munson and my friend John Freeburg helped place the concrete.

For the temporary tower, we used the leg foundations as guy wire anchors, and placed another block of concrete in the middle of the triangle to set the pipe tower on. The pipe pivots at the bottom, and can be lowered or raised using a crane hoist on the back of Nelson's truck. The arrangement works pretty well, although I am glad to have someone as experienced as Nelson when we raise and lower the tower.

Now that we have had almost four seasons of experience with the shorter tower, and have had excess power for most of that time, we see little reason to go to

the taller tower. I should point out that the wind generator is located on a very exposed hilltop site. I expected more turbulence at this height, but the machine seems to run very smoothly.

A Beautiful Machine

The big moment finally arrived. The generator had been installed on the top of the tower, the blades and tail attached, the connections made, and the tower raised. I stepped back to look and thought it was one of the most beautiful machines I had ever seen. The blades are much longer and the airfoil is more developed than on the smaller Whispers I have installed. The final step was to remove the brake and see what would happen.

Nothing happened for half a minute or so; then the blades began to spin, slowly at first. At the end of another half minute the individual blades became invisible as they began to spin around at 300 rpm. At that speed, the speed at the tip of the blades is 160 miles per hour (70 m/s). The wind speed was a modest 10 mph (4.5 m/s) or so, and I eagerly went inside to see how much was being put into the batteries.

When I looked at the ammeter on the Whisper power center, it was reading about 0.7 amps or so, which I thought was a little low. Then I discovered that the power center amp reading has to be multiplied by 10, so we were really getting 7 amps. That's more like it! 7 amps at 24 volts is approximately 168 watts, which is really quite a lot of power at such a low wind speed.

Power Center

The Whisper comes with a really cool power center that includes volt and amp metering and a place to hook up 40 amps worth of solar power as well. The power center has a place to connect the large resistive load (4,800 watts at 24 VDC—about the same power consumption and heat generation as four toasters). It also has the electronic intelligence to connect the load when the battery bank is full, using an algorithm that includes battery voltage.

Our resistive load was connected for a different voltage when it arrived, so we had to rewire it for 24 volts. The factory gave us the wrong directions, and when the wind generator was first turned on, the resistive load was not connected. Eventually, we took the box with the resistors in it apart and figured out how to wire the resistors for the proper voltage. Everything is very well made—the power center and resistor box are made of stainless steel. The power center is 17 by 18 inches (43 x 46 cm) and the resistor box is 17 by 17 inches (43 x 43 cm).

A Quiet Gift

The machine lives up to its name and makes very little noise. At very low wind speeds it really is a whisper. At

higher wind speeds it makes more noise, but there is also more noise from trees and bushes and grass moving in the wind. At no point is the noise objectionable. As my friend John Stanley says, it's the sound of God giving you free energy.

Initially the winds were very light. I decided to leave the machine up in light winds for a couple of days and then take it down to retighten and adjust everything. All day long the wind speed increased. It wasn't possible to tell if the resistive bank was working because the battery voltage did not rise high enough to turn it on. Soon the machine was putting out 30 or 40 amps, with peaks to 80 amps.

I began to worry about shutting the machine down. To use up the extra energy being generated, I turned on an electric heater, generally a big no-no with solar electric systems. Still the wind increased. At its peak, the machine put out 150 amps, well over its rated output. Previously the most amperage the battery bank had seen was about 40 amps from the PV panels. The batteries were merrily gassing away getting the equalizing charge of a lifetime. The wind became so strong that I could not shut the machine down with the brake.

The Whisper uses "dynamic braking," which simply shorts the three-phase AC leads from the generator to stop the machine. But in very strong winds, shorting the leads does not shut it off. At the time, I was not very familiar with the operation of this machine. I now know that I can usually wait for a slight lull in the wind by watching the ammeter. If I shut the switch off during a lull, I can usually brake the machine even in a storm.

Use It Up!

I went on a mission to use up the extra energy. I made bread in the bread maker. I bought some inefficient incandescent lights to replace my compact fluorescents and left them on all night. I asked the neighbors to leave their lights on. I ran the heater all night. I turned the stereo up loud. I got through the night, and the next day the wind had calmed down enough so that I could shut the machine down. The Whisper 3000 is like a 500 pound gorilla. In the wrong circumstances, it's not easy to control.

We have found that most of the time we only have to run the wind generator for a few hours every couple of days to keep the neighborhood batteries topped off. Everyone is thrilled with the extra power. It is very comforting to come home and see the wind generator working away in combination with the solar panels, providing an abundance of energy. The machine even has a little red light on it so you can see if it is producing power at night.

Complementary Power Sources

Although we have found that, watt for watt, the sun is a more reliable source of energy in Iowa than the wind, the power of the wind makes a great supplement to the power of the sun.

Access

Author: Lawrence Gamble is a consultant for solar, wind, and hydroelectric projects. He has a degree in electrical engineering and is a registered professional engineer. 1860 Woodland Dr., Fairfield, IA 52556
888-SUN-ENERGY • lgamble730@aol.com
www.sunfarm.com

World Power Technologies, 19 North Lake Ave., Duluth, MN 55802 • 218-722-1492
Fax: 218-722-0791 • sales@worldpowertech.com
www.worldpowertech.com

I'd like to thank the following people for their help and support with the project: Nelson and Mary LaFrancis, Bill and Joyce Munson, John Freeburg, Michael Havelka, John Stanley, Adam Cargill, Cecelia Connerton, Phil Scot, and Jeff Albrecht (and many others who I may have forgotten to include).



Sun & Wind Made Easy!

The EZ-Wire System Center is the ONLY hybrid controller!
(Accepts AC from the wind and DC from the sun)

DIGITAL LED MONITOR
BATTERY CHARGE CONTROL
REGULATOR DIVERSION LOAD
SELECT 12, 24, 32, OR 48 VOLTS
BRAKE SWITCH & CIRCUIT BREAKERS
EZ WIRING

MORE FEATURES than any other controller or wiring center—ALL IN ONE BOX

- COMPLETE MONITORING of batteries, wind output, solar output and DC load with optional remote display
- SIGNIFICANTLY REDUCED WIRE COSTS with AC transmission
- LIGHTNING PROTECTION with ground-based electronics

The EZ-Wire System Center is standard with every Whisper generator

WORLD POWER TECHNOLOGIES INC
INDUSTRY LEADER SINCE 1978
PHONE 218.722.1492 • FAX 218.722.0791
e-mail: sales@worldpowertech.com • web: www.worldpowertech.com
19 North Lake Avenue, Duluth, Minnesota 55802, USA

New England SOLAR HOMES™

Solar Farmhouse II™

Standard Features of a New England Solar Home

- Generous unobstructed south-facing roof area
- Passive solar configuration w/ deep roof overhangs
- Open light-filled interiors
- Standard & Custom Plans can be quoted for shipments of stress skin panel or pre-fab homes

Energy Self-Reliance Suddenly Got a Lot More Attainable
All Climates/ Solar Home Design Company

For our free brochure contact us at:
New England Solar Homes
5 Jean Road
Arlington, MA 02474
Tel 782 646 6165 Fax 781 646 6188
Email solarhomes@ecobuild.com Web www.ecobuild.com

Plan Set Options:
1 Standard Plans
2 Std. Plans Customized
3 Full Custom
Call or write for price list.

RECYCLED POWER



At U.S. Battery, we're committed to doing our part in keeping the environment clean and green for future generations, as well as providing you with premium deep cycle products guaranteed to deliver your power requirements when you need them.



**DON'T SETTLE
FOR ANYTHING LESS
THAN U.S. BATTERY
PRODUCTS!**

SIEMENS

Power anywhere.™



Siemens Solar.
So you can live
where you want.
How you want.
Call 1-800-947-6527
or visit us at
www.siemenssolar.com.

Siemens Solar
The Power to Live Anywhere

SEEKING NEW DEALERS TO HARVEST THE SUN



BP SOLAR

- We are currently welcoming applications for our BP Solar Dealer Network
- Complete dealer support: engineering, marketing, sales leads, knowledgeable staff
- Single line solar distribution - Offering the world's most efficient solar modules by BP Solar
- Join the fastest growing team of successful renewable energy dealers in the world
- Pre-engineered Utility Interactive Systems

1-800-229-7652

Fax 909-308-2388

27420 Jefferson #104B

Temecula, CA 92590

E-mail: mark@alternativesolar.com

Visit our website:

www.alternativesolar.com

Huge inventory
supplies!



Trace Engineering



Pulse



Specialty Concepts



SouthWest
Windpower



Heart Interface

BP Solar





BP SOLAR

$$\cancel{E=MC^2}$$

PV+WIND=ENHANCED POWER SYSTEMS

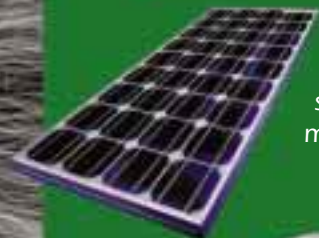

State of the art solar modules



A new generation of battery charging wind turbines

Complement your Solar Power System with clean energy from the wind. For a Power Specialist near you, call us at 1-888-BP4-SOLAR (1-888-274-7652). Business opportunities are now available!



BP SOLAR

Southwest Windpower
INCORPORATED
RENEWABLE ENERGY PRODUCTS



Still Crankin'

A PV & Wind System Ten Years Later

John Millard

©1999 John Millard

John Millard's wind and photovoltaic power system is a showcase of do-it-yourself ingenuity—proving itself for ten years.

It has been ten years since my article, *A Wind/PV System*, was printed in *HP10*. After reading the Lincoln J. Frost Sr. article in *HP70*, I would like to let you know that my system has not faded away into the sunset. In fact, I have been modestly improving it over the years, and I hope all those other people with solar and wind projects in back issues of *Home Power* have too.

More PV!

I have increased my solar power output by one hundred and twenty percent with 72 used panels from the Carrizo power plant. My total solar panel surface area is now 500 square feet (46 m²). With the help of my brother-in-law, Bill Hegerich, and his son Bill, I built four new eight by nine foot (2.4 x 2.7 m) frames out of treated two by fours. They all track the sun like the original thirteen by sixteen foot (4 x 4.9 m) frame, using

1/4 inch (6 mm) nylon ropes, pulleys, and counterweights. I have found a 30 percent increase in energy when I use the trackers.

All four nylon ropes end up on a winch drum which operates at 8.5 rpm. The 1/6 hp, 1,750 rpm, 120 VAC winch motor is geared down to this speed. There are actually two winch motors—one for the large frame, the other for the four smaller frames. The motors are operated by a power relay which works off a timer. It runs the motors for eight seconds every fifteen minutes, so the frames precisely track the sun's east-west path.

Wacky Tracking

I have a 10d nail, about 3 inches long, perpendicular to the surface of one single-axis wood frame tracker. The shadow of the nail falls on the edge of the frame. As the sun moves from the east, I watch the shadow of the nail get shorter. When the shadow lines up with the nail (or no shadow), the panels are lined up with the sun. I turn the trackers on each morning by eleven (eastern daylight savings time). Then I shut off the override switch and the electronic timer takes over. The trackers will follow the sun precisely throughout the rest of the

day until they get to the far west position, which is almost at a 55 degree angle, with respect to horizontal.

During the summer, the sun sets by eight and all five trackers are facing west. I have two reverse toggle switches which change the direction of the electric motors. I flip the switches and then turn on my override switch while they all start tracking east once again. When the trackers are all at 55 degrees facing east, I shut off power to the winches overnight. While the trackers are moving east (which takes about five minutes), I get my meter reading 200 feet (60 m) from the house where the panels, windplant, and battery house are. I take my reading from my old amp-hour meter, including total amp-hours input for the day, wind and sun. I also have a separate windplant reading. When the trackers reach full-east position, I throw the reverse switches back to forward.

I've figured out a mechanical automatic disconnect. This device stops the panels from tracking once they reach their maximum west position. When the tracker gets to the 55 degree position, it pulls its own AC power source plug to the two tracking winches that are synchronized.

Three short extension cords and single sockets are wired in series with the hot side of the 120 VAC inverter output. They are anchored on the center, lower part of each frame. They have their three associated plugs and cords that act as pull disconnects. Each is a three foot two-wire cord and plug (six foot extension cords cut in half), with the two wires twisted and soldered together and taped at the end of each cord. These three cords and plugs are anchored under the east side of three of the tilting frames, two to three feet out from the center pivot like a seesaw.

When the east side of the frame tilts up while the panels are tracking to the far west position, the cords become tight and the plugs pull out. Any one of the three will stop all the panels from tracking. Thus if the four smaller frames should reach their end stop first, power is removed from all five frames. When I reset the panels to the east, usually one of the plugs has pulled itself out and there is just enough slack in the cord to plug it in for power. These cords should be protected from water. I have two of the plug arrangements on two of the four smaller frames and one on the large frame.

Weather Patterns

The array's 130 VDC current output is between 22 and 24 amps continuous on a sunny day. I have noticed that when a cold front comes through, the current is about 24 amps continuous. But as the days progress and the humidity starts to rise, the current falls off to 22 amps, then 18 amps, and then 16 amps when it's really hazy, hot, and humid. Then we have a rainy day or two and the whole process starts over again. I've actually seen the solar panel amp meter hit 29 amps and stay there for a minute while the sun was shining through a hole in the clouds—that's 3,770 watts coming in.

But nothing beats a cloudless day, even if it's hazy. That constant 18 amps all day adds up more than those bursts from a partly sunny day. On cloudy days with light overcast, I get about 60 percent (or 12 amps) of what I get on a clear sunny day. On a really dark rainy day, it will go down 10 to 20 percent or 2 to 4 amps.

More Kilowatt-Hours!

In 1989 I had one large solar panel frame supplying me with approximately 1,300 watts—10 amperes at 130 volts, or approximately 10 KWH a day. With the additional four smaller frames with the 72 new panels, I have increased solar input to approximately 3 KW—24 amps on a good summer day. With all five panel frames tracking the sun, I have seen a total of 24 KWH input to the batteries in a day.

If there is wind, the windplant can add another 4 to 8 KWH. But I usually don't let the windplant run when there is plenty of solar energy. Why wear out the wind plant? It will automatically shut down by furling the tail

Author John Millard (left) and family with his home-built tracking PV arrays.





Four of the five PV arrays. Total PV output is about 3,000 watts.

when the DC voltage reaches 130 VDC, which usually happens early on a sunny day. My highest input in one 24 hour day was 32 KWH from wind and sun.

When the battery voltage reaches 130 VDC, a reactive inductor on the output of the inverter drops the voltage to the house by 10 volts, bringing it down to 120 VAC. The reactive inductor acts like a resistor, in series with the hot line to the house. I use an inductor instead of a resistor because it doesn't use any power.

Windplant

During the summer of 1998, I installed the TriMetric battery system monitor in my kitchen, 200 feet (60 m) from the battery house. It is good to see the charging light come on at night when it is windy. It is especially

good to see it when the hot water heater with its 1,600 watt load is on, along with some lights and the TV. The old Electro 6 KW windplant on the 80 foot tower is still running okay. I grease the turntable and other parts every year, and spray the three 8.2 foot (2.5 m) radius blades with silver paint every five years. I try to spray with the same amount of paint, so as not to unbalance the three blades.

The machine is proving its worth at night. I recently had about 1,800 watts of loads on in the house and the windplant was still generating slightly more than that. I take care of my father who needs a lot of help because of his age. He uses an electric blanket at night, and he's the only man I know who gets his heat from a windplant.

Detail of one of the home-built trackers.
Notice the concrete block as counterbalance.



Nylon ropes from winch motors provide 8 seconds of tracking correction once every 15 minutes.



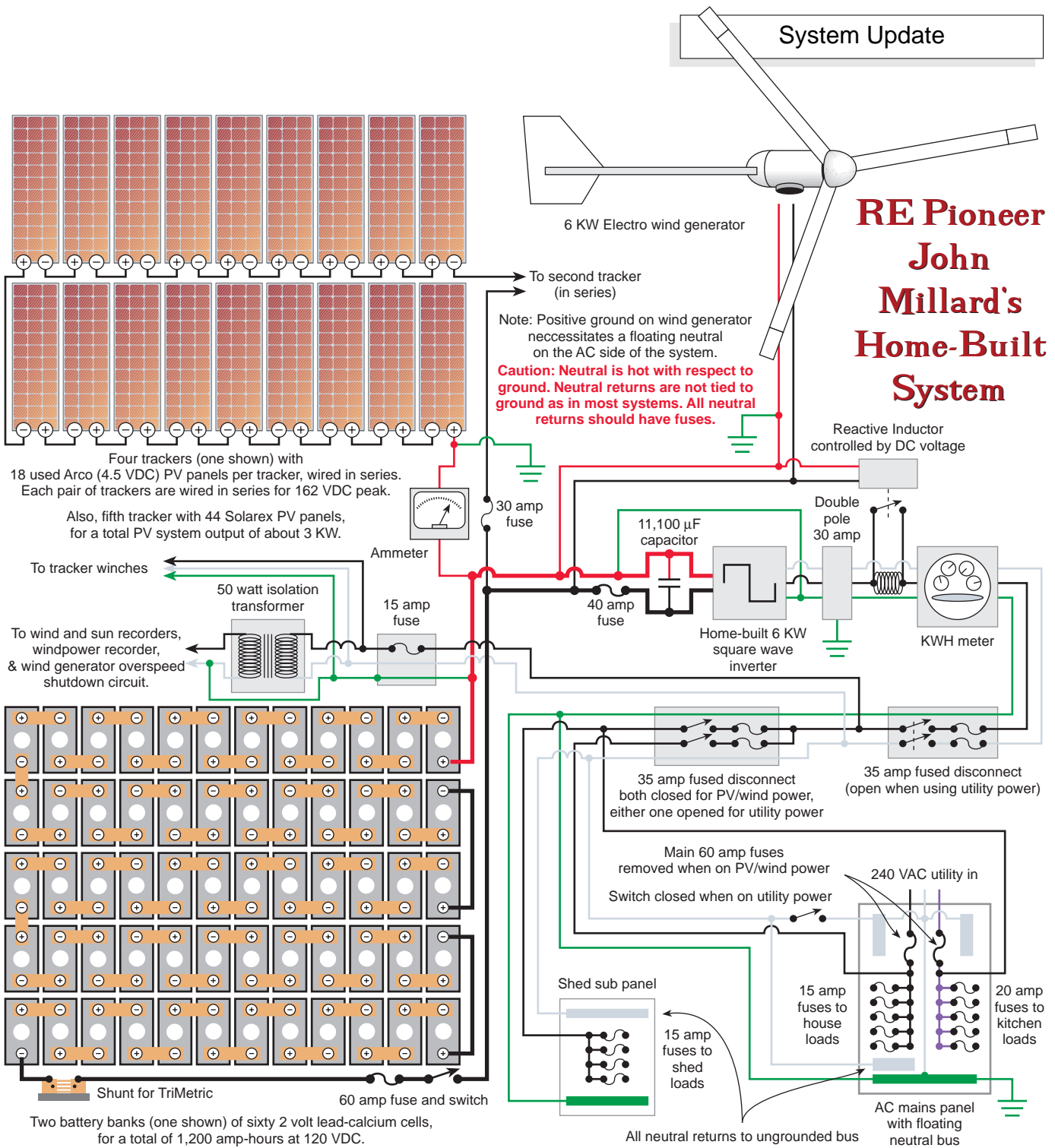

RE Pioneer John Millard's Home-Built System

Positive Ground

Since the Electro windplant has a negative hot and a positive ground, my system is the opposite polarity of most systems today. This has been a headache that I have been able to deal with over the years. When I bought the TriMetric, the dealer balked when he learned that I had a negative hot, 130 volt system. But the people at TriMetric sent me a hand-drawn schematic on how to modify it for my system. It's worked out okay.

Because of the polarity of my system, the TriMetric monitor itself is hot. So I mounted it in a black plastic

box and put tape over the push buttons. I had to make a 10 to 1 resistive voltage divider so that 130 volts DC is brought down to 13 volts DC for the TriMetric to read. I also had to build a small isolated 12 VDC power supply and battery to feed the TriMetric. This is so I don't lose all the data if my inverter power goes out.

The 200 amp shunt for the TriMetric is in the main negative 120 volt cable from the battery. So I had to fuse all the wires going to the TriMetric from the shunt, and the wires from the voltage divider. I used fast-acting 1 amp 250 V Buss AGC fuses for safety. The positive



Half of the 120 lead-calcium cells.

and negative leads from the 12 V power supply are fused with 1/2 amp 250 V Buss AGC fuses. Every wire to the TriMetric is fused for safety because it's hot.

I am absolutely pleased with this meter, with its three main functions and seven extra functions. It sure has let me know what's going on in the battery house. I have compared its amp-hour readings with my old amp-hour meter, which records wind and solar panel input each day, and my AC watt-hour meter which is hooked up to the inverter output. The readings are all the same—it's amazing!

Same Batteries

I have the same two banks of batteries—a 600 AH bank and a 500 AH bank, both at 120 volts DC. I replaced a number of bad cells, close to fifty years old, due to shorted cells from extreme positive plate growth. Some plastic cell cases have cracked because of this, but the old hard rubber cell cases are better in this situation. It's the positive plates that grow with a lot of force, not the active material. I'm down to my last spares in these lead-calcium cells. I have had these batteries for 28 years.

I do get a little anxious, as I'm sure others out there do, when all our diversion loads are on and still the voltage keeps rising on the fully charged batteries. You hate to have to go out and shut off more than half your panels. I have a regulator in the circuit, but never use it because it cuts the energy to the batteries. Some day I would like to purchase an electric vehicle, and charge it off the surplus energy of the system. That would be the icing on the cake.

We do have the utility grid here, but we rarely use it. When I first get up to the place in the spring, I spend a few days getting the system going again. Invariably there are things to repair. So I use the grid to run the house for a few days. About a week before we leave to go back to the city, I put the house back on the grid and let the solar and wind charge the batteries up full for the winter. Other than that, we're running on our alternative energy system.

Reverse Charging

I've done some experimenting with reverse charging lead-acid cells with success. It took at least five times the amp-hour capacity of the cell to get it to charge in reverse initially. I noticed at least a 10 to 15 percent decrease in capacity in the cell after doing this. I think this is because there is one more negative plate in a cell than there are positive plates.

After running down the cell to completely dead, I started the reverse charge. Caution! You can ruin your battery charger doing this. A special current-limiting charger is needed. I've had complete success in doing this and I'm still using reversed charged cells in my system. When I measured the specific gravity, it showed a full charge. I believe the reason for this is that the positive plates are negative now and have a tendency to shrink, and the old negatives which are always in good shape become new positive plates.

The positive plates in a battery are the ones that deteriorate. The negative plates don't go bad. So if you catch the battery before the positive plates are too far gone, and reverse charge it, you can have virtually new positive plates. I believe that if this is done to a battery that has plates that are still in good condition, the life of the battery can be doubled, with a slight loss of capacity. It will also delay case breakage indefinitely.

I haven't tried this on my whole battery bank, just a few individual cells. It would be a lot of time and energy to do a complete bank. I got this idea from an oldtimer years ago who had accidentally had his 6 volt car battery installed in reverse. Interestingly enough he never had any trouble with the electrical system. Don't try this in a modern car—you'll blow everything.

Household Loads

I have a 20 gallon (75 l), 1,600 watt water heater, a 14 cubic foot (0.4 m³) standard refrigerator (not frost-free), a 4.5 cubic foot (0.13 m³) freezer, microwave convection oven, a water distiller for battery water, and an E8M General Electric Elec-Trak riding lawn mower. I use the mower and water distiller as diversion loads when there is surplus power in the summer. We have numerous fans, positioned all over the house for cooling in our hot summers.

I've also added a 6,000 btu, 1,000 watt Gibson air conditioner. It has brought the bedroom temperature down to 74°F (23°C) compared to 92°F (33°C) in other rooms. I use two electric 1,500 watt heaters to heat my father's bedroom on cold fall mornings, and a third one in the kitchen before I get the woodstove going in the morning, all on at the same time.

I can run any three major appliances at the same time. And when company comes, the hot water and water supply put quite a demand on the system. A little water conservation helps when washing dishes. I should get smart and shut the hot water supply valve off a bit. Then I wouldn't have to say anything every time we have company.

Lead-Calcium Batteries

I bought a new set of batteries for the Elec-Trak lawn mower—three Delco Voyager 100 AH 12 V sealed lead-calcium flooded batteries. This will be their fourth year in use. They are really a work saver, with no watering the 18 cells, and they are corrosion-free.

What's great about these batteries is that they will hold full charge through the winter months. This is why I like the lead-calcium batteries. If my main bank were lead-antimony, they would have lost most of their charge in the same time. I'm glad Delco has come out with a lead-calcium deep cycle battery.

Elec-Trak

Over the years I've used many shop tools and have retired a few walk-behind electric lawn mowers. But the old Elec-Trak keeps going, though I had to replace the two mower motors. The motors themselves were okay, but the shafts broke due to hitting rocks. I replaced them with stronger 7/8 inch (22 mm) shaft motors from Kansas Wind Power instead of the original 3/4 inch (19 mm) shaft motors.

So after two new motors and three new batteries, it's been mowing over 1/2 acre of lawn for three years now. And it still turned out cheaper than buying a new gas riding mower. Anyway, that would have been against my principles of a complete alternative energy household.

I use my Elec-Trak and a trailer to haul firewood that I collect from the surrounding area. I cut all my firewood with an electric chainsaw. At 2.5 hp, it draws 12 amps.



John with his home-built, 6 KW, 120 VDC in, 120 VAC out square wave inverter. It draws 3 watts at idle and is 99.5 percent efficient with a 1,000 watt load.

More Power for Relatives

I use approximately 12 KWH in our all-electric home daily. It rises to over 20 KWH a day when we have company. And I have to have all the panels tracking if I want to stay ahead. I leave them flat at times in the 12 noon position if it stays sunny for a long period of time. But I was caught short last summer when we had four relatives up for a couple of weeks and the weather went sour. I realized after a week of entertaining that the batteries were half discharged.

I then proceeded to get all the panels tracking again. But days of cloudy weather afterwards almost shut the system down. If I'd had the panels all tracking during the first week the company was up, the batteries would have been close to full when the weather turned cloudy and overcast. Although the system survived, it took nearly two months for the batteries to reach full charge again when everyone went home. This year when the relatives visited, it only took one week to bring the batteries back to full charge, because every day was sunny.

Balanced System

The solar/wind system seem to be pretty well balanced with our loads. See the table for monthly input and energy used for June, July, August, September, and half of October, 1998.

The water system is our own and when I use the washing machine, I can't use the electric range. As the washer is filling with water, the water pump kicks on. And when it is washing, the water pump and the hot

Millard System Energy Production & Use

Month	KWH Made	KWH Used
June	363.7	372.7
July	470.0	430.0
August	417.5	387.5
September	418.6	402.0
October 1-17	163.3	187.0

Solar panels are left in the 12 noon flat position approximately 25% of the time.

water heater are on, which is a 35 amp load on the inverter. So I dare not turn on any other appliances. Three at the same time is the limit. So I don't cook when I'm doing a wash.

The range consists of two double-element Munsey buffet stoves. Each stove has one 600 watt element and one 1,000 watt element. I use these two stoves for all cooking, three times a day—I've been using them for years. All four elements can be used at the same time. The stove elements and housing must be grounded with a three-wire cord and three-prong plug for safety to avoid the risk of electrical shock. These stoves fit on top of the gas range nicely. The gas range is shut off at the propane tank and is rarely used. The microwave oven, which draws about 1,200 watts, is also used often.

Homebrew Inverters

Power electronics have always been a keen interest of mine, which led me to build an SCR (silicon controlled rectifier) inverter 20 years ago. It was 3 KW, 130 VDC in, 120 VAC out. But it drew too much current, idling at 2 amperes. Then when the power MOSFET came along, with its 30 amp rating at 200 VDC, I set out to build a more powerful inverter with double the rating of the SCR inverter.

Since my article in *HP10* in 1988, I have been using my new power MOSFET inverter. MOSFET stands for metal oxide semiconductor field effect transistor. It is the heart of the inverter, which is the heart of my whole alternative energy system.

I have had a few failures with power FETs. They can explode with flying shrapnel under short circuit conditions. My work was well worth it though. I made a 6 KW, 120 DC in, 120 VAC square wave output inverter, and have been using it for many years in my solar and wind energy system at my home in upstate New York. It uses 25 *milliamperes* at 120 VDC in full-on condition—only 3 watts.

So you can have a clock radio on it all the time without concern of power loss. It is as if there is no inverter in the circuit almost. It has no transformer. The direct DC in feeds the power FET bridge circuit and its square wave output feeds the house load. I can boldly say it is 99.5 percent efficient with a 1,000 watt load. This is old stuff though, since it's been working over ten years now.

Square Wave Advice

I have a bit of advice about square wave inverters. Do not put a capacitor across the output to round off the edges. It will blow the inverter because of the fast rise time of the square wave high frequency. The capacitor acts as a short (very low surge impedance). I did try it with just a 2 microfarad 600 VDC capacitor and the test inverter blew. There was nothing wrong with the capacitor.

Over the last eight years, I have used over 10,314 KWH through the inverter with one failure due to short circuit in 1992. An unprotected plug and a raised screw on an outlet plate caused a short. That short was too fast for the main double-pole ground fault 30 amp breaker, and the inverter blew. Fortunately, in two days I replaced the four FETs that blew (out of the eight total), and I was back in business. Since then it has been okay.

Induction Generator

I tried something this past winter that may interest *Home Power* readers. Knowing that an AC induction motor can generate power if it is run faster than its normal running speed (1,725 rpm for my 1/3 hp AC motor), I hooked up an old gas lawn mower engine to drive an AC motor. I have an rpm indicator—a great instrument. You just put a small piece of reflective tape on the pulley or shaft you want to measure, and you shine the flashlight instrument at the tape. A liquid crystal readout gives you the rpm of the pulley.

My interest was running the AC four pole induction motor off the square wave inverter. Would it feed power back to the DC source through the inverter while it was on at the same time? Well, it does very well. With an oscilloscope monitoring the wave form, it remained a square wave. Square wave AC voltage increased and the feedback diodes in the inverter did their job of rectifying that AC.

There was a 4 1/2 inch (11.4 cm) pulley on the AC motor and a smaller one on the gas engine. I had a small 25 watt lamp load on the inverter, and a 1,000 watt heater in series with the AC motor and inverter. When I got the motor running at about 1,750 rpm, I shorted the 1,000 watt heater out. The DC current to the inverter dropped slightly, and when I revved up the gas engine, the DC current to the inverter dropped to zero.

When I revved up the engine more, the current began flowing into the batteries (through the inverter backwards). I was able to get the current up to +3 amps into the battery with the AC induction motor as a generator hooked up to that small lawn mower gas engine with the throttle wide open. It was running at 3,476 rpm.

The AC motor was running at 2,034 rpm belt driven from the gas engine. It actually works. I was very pleased. The inverter didn't fail and I learned that it is a two way inverter/converter. I'm still finding out the inverter possibilities ten years later. The only puzzling thing is that the AC amperes from the old 1/3 horse AC motor were up to 13 amps AC instead of the normal 6 amps running to produce +3 amps DC on the other side of the inverter. That 3 amps DC at 125 volts equals 375 watts that the 1/3 horse induction motor was generating.

My conclusion is that any AC induction motor can be used as a generator if its rpm can be driven above approx 2,000 rpm for 1,725 rpm motors, and of course double the rpm for 3,450 rpm induction motors. Do not try this with a commercial inverter. Also, AC motors may overheat due to high reactive current.

Still Charging Ahead

I really appreciate having the subscription to your wonderful, information-packed magazine. I wish you continued success. Thanks for the opportunity to share more about my system. I'm still around—I have not faded away...

Access

John I. Millard, WA21BV, Winter: 46-27 157th St. Flushing, NY 11355 • 718-358-6375
 Summer: PO Box 221, Round Top, NY 12473
 518-622-3995



! NEW PRODUCT ANNOUNCEMENT !

48 VOLT VERSION OF GENNYDEECE

- * 55 PLUS AMPS AT 48 VOLT
- * BULK, EQUALIZE, FLOAT ANY SIZE BATTERY UP TO 1000 AMPHRS!
- * HEAVY DUTY CONSTRUCTION
- * COMMERCIAL RATED OVERHEAD VALVE HONDA ENGINE, W/ LOW OIL SHUT-DOWN
- * PROPANE AND ELECTRIC START AVAILABLE

"Use half the gas and double the reliability of your back-up"



Introductory Price: \$2,595.00

Information:
Feather River Solar Electric
 5575 Genesee Rd.
 Taylorsville, CA 95983

530-284-7849
www.psln.com/frenergy

Powered by
HONDA
 ENGINES
 Authorized O.E.M



Modern Super-Energy-Efficient Refrigerator / Freezers

- SFRF-10 & SFRF-19 Uprights
- SFRF-6 Chest Models
- Danfoss Compressors
- 4-5" Case Insulation
- Digital Controls
- US Manufactured
- DC & AC Models

Immediately Available



NEW! The World Of Solar 4.0 NEW!

- **Photovoltaic Design** A powerful new CD for designing solar systems. With hundreds of graphics, sounds, & products. *PC Version Only
- "Bus Tour"
- **Product Library**

Solar Fan

- DC-Powered
- High Efficiency
- 18 Watts
- High Quality
- Brass Hub



Simpler Solar Systems

Home Power Systems

- Pre-Wired
- Plug-together
- Pre-engineered
- Install in 2 hours



Purchasing 800-248-9786 • 3118 W. Tharpe St, Tallahassee, FL 32303
 Fax: 850-576-5274 • Web: www.y2ksolarpower.com • Email: Simpler@simplersolar.com

Worried About a Water Emergency?

The solution is simple -

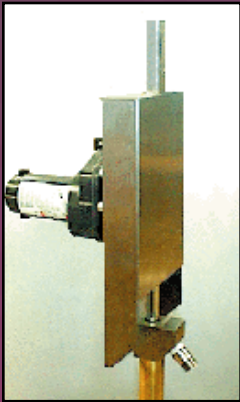

Ideal for remote cabins. Perfect for emergency water.

High precision hand or solar powered water pump.
Fits down inside your existing water well casing.
Does not interfere with your existing submersible.
Can be inter-tied with your existing main water line.
For emergencies or sustained pressurized pumping.
Easy installation in under 2 - 3 hrs. for most wells.
Hand pumps effectively below 350' at up to 100 p.s.i.
12v motor operates with a battery and 30w solar panel.
Far more cost effective than powering a submersible.
Changes from 12v motor to manual in under 5 minutes.
Can operate with any 12v charge source and a battery.

*Of all the things important,
there is nothing MORE important than your water.*

AlternativeEnergySystemsCo

501-839-4017

www.poweriseverything.com

Call us – or visit our comprehensive web site.

Dealer inquiries are welcome.

Some Things Simply Thrive in the Sun.

**Coming
Soon!**



Introducing "HIT POWER 21"

Featuring 17.3% Conversion Efficiency

Sanyo/Solec bring you the Next Generation of Hybrid Solar Cells, featuring the World's Highest Conversion Efficiency for both Residential and Commercial use.

The HIT (Heterojunction with Intrinsic Thin-Layer Solar Cell) is a hybrid composed of a thin single crystal silicon wafer surrounded by layers of ultra-thin amorphous silicon. HIT modules also feature dawn-to-dusk charging and can be placed in high temperature locations without much decrease in output.

Ultra-Thin, Ultra-Efficient... Unrivalled Performance.
It's Advanced Solar Technology you'll want to know more about.



...bringing the sun down to earth

For more information, call (310) 834-5800.

Rethinking



The Good Life

Christine Parra

©1999 Christine Parra

Redwood Alliance's *Take Your Bedroom Off the Grid* workshop crew '99. This year—grid intertie.
Author Christine Parra is on the lower right.

It had been a long, dark New York winter. Each morning, sleepy commuters, *Wall Street Journals* in hand, roused themselves from their morning naps as the train pulled into Grand Central Station. And each night, the Metro-North commuter train between New York and Connecticut made its trip back. I was one in an army of trench-coated, newspaper-carrying businesspeople. The spring day had been much like any other except that, in place of a newspaper, I held an issue of *Home Power* in my hand.

I had picked up a copy during a Solar Energy International workshop in Colorado the previous summer, and have subscribed ever since. I was tired of the *Journal*, which was so ubiquitous on the trains and in offices. I realized that there was more to life than constant earning and unbridled consumption, but couldn't identify it.

The Good Life?

I had made a model life: the executive house in the suburbs on 2.5 acres of land, sport utility vehicle, car, etc. There was, however, little connection with the seasons, no letup in the pressure to pay the huge monthly mortgage, little time for peace and reflection, extracurricular activities, or relationships. The illusion of wealth was accompanied by a severely impoverished quality of life.

But in this issue of *Home Power* (HP22, p. 26), I read about a group of people at Humboldt State University (HSU) who were making hydrogen from the sun and using it in a fuel cell. Something in the article struck me: these people were developing a technology that would make a clean, domestic hydrogen economy possible. I was inspired to move to California and study engineering.

I became a graduate student in Environmental Resources Engineering (ERE) at Humboldt State University in the fall of 1992. By the spring semester, I had enough background to complete basic tasks at the Schatz solar hydrogen facility as a volunteer. By the end of the 1993 spring semester, I was working as a paid employee at the Schatz lab, which I continued to do throughout my student years. After two more years of statistics, engineering, and design courses, as well

as calculus, physics, and chemistry prerequisites, I wrote a thesis and graduated with a Master's Degree in ERE.

Hydrogen Research

Peter Lehman and his colleague Charles Chamberlin direct the Schatz Energy Research Center, which is funded by a generous grant from Dr. L. W. Schatz, a retired businessman and self-made millionaire. The center has produced the only solar hydrogen fuel cell facility in the world, as well as America's first fuel cell powered car. The center's staff consists of a talented bunch of fifteen like-minded engineers and scientists, mostly graduates of the HSU Engineering program.

Those of us who work at the Schatz Energy Research Center acquired design, fabrication, and operating experience in solar electrolysis, fuel cells, integrated power systems, and programming. My own activities have included photovoltaic (PV) and fuel cell system design, marketing and economic analysis, budgeting, teaching, and even hands-on involvement with the hardware. Our projects have ranged in size from small, local initiatives to multimillion dollar, government-funded programs.

Take Your Bedroom off the Grid

In my eagerness to become more familiar with the hardware for small PV systems, this past May I attended a *Take Your Bedroom off the Grid* workshop. This weekend workshop was hosted by Redwood Alliance and taught by Johnny Weiss of Solar Energy International. Sharice Low and Chane Binderup of Redwood Alliance did an excellent job of organizing the workshop. Bob-O Schultze of Electron Connection and Joe Schwartz from *Home Power* rode herd on the installation portion and shared their expertise.

Johnny Weiss, Solar Missionary, is a master of RE education and instructor of many of SEI's workshops. Experience him if you can.



Jay Peltz of Alternative Energy Engineering helps students get their hands on renewable energy equipment.

The main goal of the workshop was to show people how to take advantage of the modularity of PV systems. You can start slowly and gradually increase the size of the system as more cash becomes available. This article contains ideas from the course that might help you with your PV system design. These ideas might also help you design some other parts of your life.

Independence & Conservation

Renewable energy systems are dependable, quiet, and clean. They make independence possible, and encourage conservation by making you aware of your use of resources. With RE systems, you have a limited amount of energy available for consumption. You have no choice but to be in touch with natural cycles. You can't have a small PV system and be careless or inattentive. You have to be thoughtful about your activities.

Are we ready to apply these ideas to other parts of our lives too? To figure out the difference between true needs and desires? To understand the difference between standard of living and quality of life? To stop chasing material goods to achieve happiness? To apply technology thoughtfully? To look at how we produce (in largely mechanistic, repetitive, specialized jobs) and consume (often in programmed and isolating ways with destructive results)? Are we ready to change? To earn less, use less, and have a greater connection with the natural world? Maybe—you can decide for yourself, based on the following points covered in the course.



Demystifying RE installation is one main workshop objective.

Know Your Resource and Determine Your Load

You really haven't started a PV design until you've found out how much solar energy is available to you and how much energy you need for your lifestyle. This is called determination of resource and load profile.

The resource is pretty much set. The larger question is how you decide to use what is available and how much you want to pay for certain conveniences. Remember, it's costing us all the time we work during our lives to earn the money we need for our lifestyles. It pays to consider resource versus load.

Don't Make More, Use Less

It turns out that using less is easier than making more. As you're designing your renewable energy system, you'll find that you pay quite dearly for small conveniences. This doesn't mean that you shouldn't make your system large enough to make you and your family comfortable. But it pays to think twice about each habit.

Have you ever calculated how much money it takes to satisfy your minimum needs? Or calculated the actual cost of certain habits (let's be fair—dollar cost to you as well as impact on the planet)? Have you tried measuring that cost in hours at work or in stress?

Here's a secret that I've discovered since exiting the rat race: if I consume less, then I need to buy less and I need to earn less money to buy it. In addition, I have a smaller impact on the world. Or, taken one step further, if I consume just enough to satisfy my spiritual and physical needs (as opposed to my media-fabricated desires), then I spend less time earning and more time hiking, dancing, and playing music.

This is the difference between "quality of life" and "standard of living." Which makes me happier: to be doing things each day that I enjoy and learn from, or to have as many material goods as I can accumulate in a lifetime?

Remember also that the goal of maximum convenience can cause amazing amounts of inefficiency and some

A Small Residential PV System

In Redwood Alliance's *Take Your Bedroom off the Grid* workshop, we had the opportunity to get some hands-on experience with multimeters, batteries, and photovoltaic panels (PVs). On the last day, we installed a system at the house of two renewable energy enthusiasts, Elias Elias and Gretchen Ziegler.

The couple had attended the *Take Your Bedroom off the Grid* workshop two years ago and had wished for their own system ever since. By the time the course participants arrived on site, most of the preparation work had been completed and the system was ready to be installed. Participants had the opportunity to attach the panels to the rack, wire them together, and mount the rack on the roof. We also connected the charge controller, inverter, and batteries, and then the E-Meter—the user interface.

The system contains four Solec 80 watt modules (as many as the owners could afford) and four 6 volt Trojan L-16 batteries wired in two series pairs for a capacity of 700 amp-hours at 12 volts.

Gretchen and Elias wanted to be able to add more PVs later, and to tie the system to the grid, so they needed a synchronous inverter. They decided on a Trace 2.5 KW unit, which allows for expansion and puts out power clean enough for the grid. The system also contains a Trace charge controller and an E-Meter, which displays system current and voltage, as well as amp-hours left in the batteries. Balance of system components include breakers, shunts, cables, connection boxes, and miscellaneous hardware and conduit.

What's the Cost?

The total retail cost of the system was US\$7,211 (see the cost table). In the somewhat cloudy climate of Arcata, which gets an average of about 4.4 peak sun hours a day, the system will provide 1,200 watt-hours of energy on an average day (68.9 W x 4 modules x 4.4 peak sun hours per day). Note that I've derated the power output of the modules to PVUSA test specs.

Homeowners installing PV systems in sunnier climates will have higher output due to greater insolation, so the

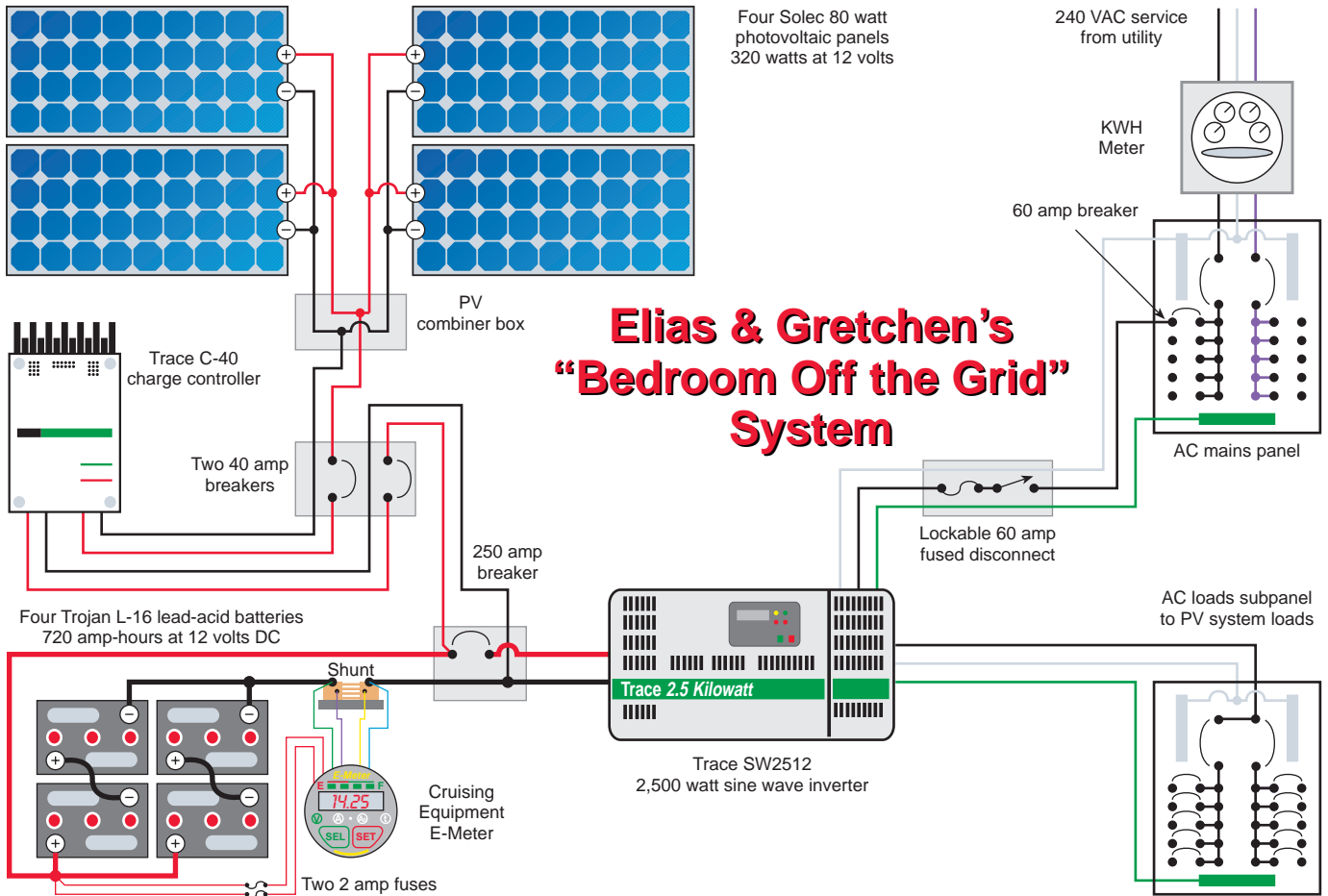

system life cycle cost will be lower. The cost per KWH for a system installed in the desert would be 68 percent of the price of a PV system installed in Arcata, because there would be as many as 6.5 peak sun hours per day.

Elias and Gretchen completed all of the documentation necessary to sell power back to the grid. According to Assembly Bill 1755, any California consumer of electricity and owner of a system less than 10 KW in size may sell as much power back to the utility as s/he consumes. The utility company must pay the market rate for the power. You run your meter backwards, a concept called net metering.

This makes possible a minimum monthly electric bill of five dollars. As described above, the system will produce about 1.2 KWH per day. Pacific Gas & Electric (PG&E) charges 13.321 cents per KWH to residential consumers of electricity in Arcata, California. So the total gain of net metering for Elias and Gretchen's system will be about 16 cents per day, or about US\$59 per year.

Subsidy & Credits

Elias and Gretchen also decided to take advantage of the California Emerging Renewables Buydown Program. The California Energy Commission (CEC) offers rebates of up to US\$3 per watt or 50 percent of the system purchase price (whichever is less) to those who install PV or wind systems. The applicant must derate the PV modules slightly (based on PVUSA tests) and account for inverter inefficiency. Qualified equipment must be used (see list on CEC Web site).

The allowed power rating per module turned out to be 68.9 W for the Solec 80 W modules and the allowed Trace inverter efficiency was 90 percent. At the current offering of US\$3 per watt, this produced a rebate of US\$744 (68.9 W x 4 modules x 90% x US\$3/W).

Finally, there is a 10 percent investment tax credit available from the federal government for solar electric, solar heating/cooling, or geothermal electric power equipment (use Form 3468 and report the answer on Form 1040, line 47). Keep in mind that you have to reduce the basis of the property by the amount of other



The fun part—puttin' panels on the roof.

questionable system design. Think about convenience first and you wind up dragging oil from the Persian Gulf in order to drive your car six miles down the road to the school or store.

Our Resources Are Not Infinite

With a renewable system, you buy a bucket of energy. You no longer behave as if you were connected to an infinite grid. If I behave as though all resources were limitless, my behavior is not sustainable. Well—face it—we're not connected to an infinite supply of anything. But this is not actually bad news. A change in consciousness can lead to enjoying living with less.

Do you remember from childhood what life was like when time was infinite? A change in consciousness could produce uncluttered minds and houses, more

subsidies (such as the US\$744 from the CEC). In the case of our two homeowners, this credit is equal to US\$647 [10% x 7,211 x (1-744/7,211)]. This slightly convoluted way of calculating the credit can be found on the IRS Form 3468 and in its instructions.

Compare the Cost

We know that it's not fair to compare renewable energy to fossil fuel energy economically. Fossil fuels carry a political cost, economic risk, and high government subsidy. The technologies that allow us to use fossil fuels are highly developed and have had many years to become less expensive. The extraction and burning of fossil fuels produces emissions that affect our health as well as the quality of our air, water, soil, and climate.

However, most consumers will compare the cost of grid power to the cost of power from a home PV system. So,

freedom, independence, and time. Such a shift is akin to the form of medicine that uses pleasure to cure addictions—life feels so good that after a while you forget about what you had to give up.

Not Every Technofix Is Useful

Just because you can do it doesn't mean it's a good idea. Elegance and simplicity are often more valuable than incorporating a lot of expensive, highly developed technofixes in your system—and in your life.

Consider this: my partner and I recently went to buy a refrigerator for our new house. The store offered a dizzying variety of options: 18 to 30 cubic feet (0.5–0.8 m³); with an external or internal icemaker or without any icemaker; with the freezer on the bottom, side, or top; highly efficient or not efficient at all; and black, white, or stainless steel.

What is it that made me wish for the largest, top-of-the-line model? Did I think to ask, "What are my exact requirements and how much of a refrigerator do I truly need?" It's easy for me to say that California's gasoline prices are too high. But rarely do I take offense at a salesperson's suggestion that I "deserve only the best," even though it'll cost me (and the environment) dearly. What if "the best" is not the biggest, most expensive, or most advanced, but just what fills my specific need?

There's No Substitute for Common Sense

If you're about to put in a PV system, know your site. Go there, live there if you can, get to know when and where the sun rises on the property at different times of the year and understand when you'll need the most power. Keep in mind that no two renewable energy systems will be completely alike, because all sites are different and all load profiles are different. There's no

let's see if the net metering, California rebate, and federal tax credit made the price of the PV system power competitive with that of grid power. This is accomplished by a life cycle cost analysis. I won't show the details here, but here are some highlights:

	<i>With Batteries</i>	<i>Without Batteries</i>
System Cost	\$7,211	\$6,231
CEC rebate	-\$744	-\$744
Federal investment tax credit	-\$647	-\$559
Net upfront cost	\$5,820	\$4,928

For the analysis, I assumed that there was a positive cash flow from net metering of US\$59/year (described above), a 25-year life of the system, battery bank replacement every eight years (for the scenario that includes batteries), a discount rate of 5.5 percent, an

System Costs

Item	Cost (US\$)
Trace SW2512 inverter	\$2,445.00
Four Solec modules, 80 watt	\$1,796.00
Four Trojan L-16 batteries	\$792.00
Two Seas universal rack, 6 module	\$460.00
Trace DC250 breaker	\$275.00
E-Meter with shunt	\$198.00
Trace C40 charge controller	\$145.00
Misc. hardware and conduit	\$115.68
A.E.E. SWCB conduit box	\$85.00
Two #4/0 inverter-battery cables, 8 foot	\$74.00
#6 wire, 230 feet	\$64.40
AC subpanel	\$53.15
#2 wire, 67 feet	\$36.85
Four #2/0 battery interconnect cables	\$32.00
Combiner block for PV	\$22.25
Grid disconnect with box	\$20.42
6 by 6 by 4 inch rain-tight box	\$20.00
2-circuit breaker box	\$17.50
E-Meter wire, 20 feet	\$15.40
Two 50 amp DC breakers	\$13.90
Shipping for rack	\$12.00
Twelve Carflex fittings	\$11.88
60 amp AC breaker	\$11.25
6 by 6 by 4 inch elect. box	\$8.20
Labor donated	\$0.00
Total	\$6,724.88
Sales tax	\$487.55
Grand Total	\$7,212.43



Elias and Gretchen are proud parents of a grid-intertied photovoltaic system which produces clean energy.

easy answer, and only your thoughtfulness can give you the system that's right for you.

In our own lives, there's nobody to tell us when we're wasting our hard-won resources of time and money. The average American spends about fifteen hours a week in front of the TV, and makes numerous purchases that may only meet the criterion of immediate gratification.

We're In This Together

PVs come from corporations. Pick your favorite polluting, government-subsidized, fossil fuel company. And I hope that these corporations make money at their PV production. Because that's how change will happen—when we make it profitable to do the things that have a smaller impact on the environment.

inflation rate of 3 percent, an interest rate of 2.5 percent, and a salvage value of the panels of 10 percent of cost. I used the Sandia Labs method for computing life cycle cost.

Based on these assumptions, the life cycle cost was US\$0.93 per KWH for the system with batteries and US\$0.31 per KWH for the system that did not have batteries. In the desert, the cost is US\$0.21 per KWH for the system, excluding batteries. These prices can be compared to the PG&E price of US\$0.13.

Note that I've done the analysis with batteries and without them. Many consumers who are connected to the grid may elect not to include batteries in their systems. Some people like batteries because they allow the system to provide power when the grid is down. I would recommend careful consideration

because such a convenience carries a hefty cost.

One of the main points brought out in the workshop was that batteries are the most common cause of problems in PV systems. In addition, they are expensive and bad for the environment. Using the grid to store PV electricity is easier if you are already connected anyway (especially if you wish to provide only a portion of your power with PVs). As shown in the analysis, the batteries nearly triple the system lifetime cost, even when you assume a very long battery lifetime.

Gretchen and Elias were fortunate enough to be able to fund their whole system. But the great thing about PV systems is that they can be simple or complex, small or large. An investment of \$50 a month can be the beginning of clean electricity for an entire family—and a cleaner environment for everyone. It's our choice.

Education

No matter what ideals we hold, most people need and wish for similar things in life: satisfaction of human needs for food, clothing, and shelter; a sense of belonging, love, personal growth, and play; and connection with the natural world. When we work together and lead thoughtfully examined lives, we can meet our own needs without jeopardizing the ability of others (present and future) to meet their own needs.

Newton said that "a system will remain in equilibrium until a net force acts upon it." Renewable energy can be the net force that acts upon our collective consciousness in favor of change. Living with renewable energy is a great way to make us aware of everything else that we consume. It renews our respect for each other and our reverence for our planet.

Access

Author: Christine Parra, Schatz Energy Research Center, Humboldt State University, Arcata, CA 95521
707-826-4345 • Fax: 707-826-4347
cep3@axe.humboldt.edu
www.humboldt.edu/~serc/index.shtml

Redwood Alliance, PO Box 293, Arcata, CA 95518
707-822-7884 • redwood.alliance@homepower.com
www.igc.org/redwood

Solar Energy International, PO Box 715, Carbondale, CO 81623 • 970-963-8855 • Fax: 970-963-8866
sei@solarenergy.org • www.solarenergy.org

Emerging Renewables Buydown, California Energy Commission, 1516 9th St., MS 45, Sacramento, CA 95814 • 916-653-2834 • Fax: 916-653-2543
Buydown Info: 800-555-7794
smiller@energy.state.ca.us
www.energy.ca.gov/greengrid

Workshop Sponsors:

North Coast Co-op, 940 9th St., Arcata, CA 95521
707-826-8668 • Fax: 707-826-8666
halfrihn@northcoastco-op.com
www.northcoastco-op.com

Electron Connection, PO Box 203, Hornbrook, CA 96044 • 800-945-7587 or 530-475-3402
Fax: 530-475-3401 • econnect@snowcrest.net
www.electronconnection.com

Alternative Energy Engineering, PO Box 339, Redway, CA 95560 • 800-777-6609 or 707-923-2277
Fax: 800-777-6648 or 707-923-3009
energy@alt-energy.com • www.alt-energy.com

Sun Frost, PO Box 1101, Arcata, CA 95518
707-822-9095 • Fax: 707-822-6213
info@sunfrost.com • www.sunfrost.com



Trojan Battery

four color on negatives

7.125 wide
4.5 high

“When Hurricane Georges hit Puerto Rico, Two Seas’ mount saved our PV system from disaster.”

- Capt. Denis Martinez, U.S. National Guard

{ 98% shipped in 24 hours }

**Mounts that exceed toughest U.S. hurricane codes,*
backed by our 20-Year warranty.**



Mounts, battery enclosures, and racks available in a wide selection of models to meet any requirement.



Two Seas Metalworks
Willits, CA 95490 USA
800-227-9523
www.2seas.com



*SBC-1606 (110 mph winds). Two Seas mounts rated for 125 mph winds.

Dyno Battery

full page
four color
on negatives

this is page 46

Get **More** for Less



In just one year, these Solarex Millennia modules will have generated an amount of electricity equal to the energy used in their production. Note: Actual photograph of Millennia modules with patented Integra™ frame.

Thinking about an environmentally friendly solar electric system for your home?

Consider this—Solarex's new Millennia™ modules generate enough electricity in their first year of operation to offset the energy used to produce them.

While Millennia is generous in delivering electricity, it's a miser when using scarce resources. In fact, Millennia needs less than 1% of the silicon required to make equal-output crystalline modules. Also, Millennia modules don't contain potentially toxic or scarce materials.

Millennia by Solarex, the leader in solar electric technology for more than 25 years, offers an attractive appearance, greater efficiency, better stability than previous generations of thin film, as well as a choice of framing options for easy installation.

Millennia delivers all of this at a lower cost to the environment, and what's even better, a lower cost to you.

Millennia: *Proving you can get more for less.*

Contact Solarex today for more information.



It could take five to ten years for comparably rated monocrystalline modules to generate the electricity equal to that used in their production. Note: Computer simulation showing comparably rated monocrystalline system and its frame.



SOLAREX
The Natural Source for Electricity™

630 Solarex Court
Frederick, MD 21703
Phone: 301-698-4200
Fax: 301-698-4201
<http://www.solarex.com>
Info@solarex.com

Mali Solar Cooker Project —One Year Later



Lanseni Niare

©1999 Lanseni Niare

Dave Berger (behind cooker) and villagers in Banamba, Mali.

The ultimate challenge in any society is making people change, even if it is for the better. There is a Bambara proverb in Mali, West Africa, that reflects this challenge: *The habit of doing is second nature*. To create any change among people, you have to accommodate their needs. To do this, you must be creative, motivated, and very understanding.

Evaluation

In 1995–96, I was in my native land of Mali with my friend Dave Berger to introduce 98 solar cookers in several areas of the country (see *HP60*, page 50). A year later, I was fortunate to leave another winter behind in the states and travel to Mali again. While I was there, I talked with some of the individuals who were involved in the solar cooker project. I was also able to evaluate the usefulness of the cookers to some of the people who had received them.

Time limitations and transportation constraints did not allow me to fully evaluate the use of the cookers in the very remote villages. My evaluation was not comprehensive or complete. We had given out survey forms when the cookers were distributed, but getting them back was much harder. Many had been lost or ignored. Individuals and organizations who were supposed to conduct the follow-up evaluations did not do so for various reasons.

Solar technology is still a very new concept in Africa, even though the use of it has been introduced by various means. The most common form is photovoltaics. But in Mali, very few people can afford this type of solar energy use because of the expense involved.

The Cooker

The solar cooker model Dave and I decided on was a simple design which reportedly functioned well in Ecuador and Kenya. It is made out of affordable materials that are widely available locally. The cooker design is a plywood box with two pieces of glass on top and a door on the front side. The inside four walls are covered with aluminum foil for reflection, and a piece of

metal painted black is at the bottom of the box. A board is attached to the top with hinges, and foil on the inside of it reflects the sun's rays into the box.

For the project to work effectively, local people had to be trained to build the cookers. Dave provided much of the explanation to the carpenters and the metalsmiths, while I translated into French and the local language, Bambara. The local carpenters were smart enough to quickly understand, and within two weeks, we had our first cookers built. Before we distributed the cookers, we trained the users and educated the key personnel. We were assisted by regional newspapers and radio stations, and different organizations on the local level.

Hurdles

The structure of the Malian family and the basic diet were two major hurdles our project faced. Families in Mali are quite large—up to 20 people—requiring huge cooking pots. So we tried to target small and educated families (10 people or fewer) to start with.

One of the staples of their diet is *toh*, a dish similar to mashed potatoes, made out of millet flour. It is cooked by boiling water and then gradually adding the flour to the water. It is difficult if not impossible to make it in a solar box cooker, since it requires high cooking temperatures and frequent opening of the box.

Upon my return to Mali, I was able to contact some of the individuals who were involved in distributing the cookers to Malian families and some of the families who had received the cookers for use. We discussed how often the cookers were used, problems with use, durability of the cooker, and what the cookers were used for.

The use of the cookers was dependent on the season, even though the number of sun days is very high. It is also dependent on the daily activities of the family, especially the women, who were the primary users of the cookers. I found out that the cookers were most often used between 11 in the morning and 4 in the afternoon, when the sun was most intense and the women were home to prepare the early afternoon meal. Due to the time and temperature needed to cook meals, cooker use was limited to miscellaneous cooking rather than full meal preparation.

Build on Failures

As with any project, success can only build on problems discovered in



the early phases. During visits to several of the families, I was disappointed to find the cooker sitting neglected in some corner of a room. In conversation with the individuals who received the cookers, I quickly learned that the cookers had some problems. These problems usually fell into these categories:

- The ever-present dust constantly settled between the two pieces of glass, and cleaning was very impractical on a daily basis. Glass is an uncommon and expensive material in Mali, and is not easily handled. Because it needed cleaning, breakage was a common problem. This problem might have been avoided by sealing the glass with silicone, but we chose not to use it because we only wanted to use materials available in-country.
- Most families were not using the proper cooking pots or pans. The cookware was either not properly painted black on the outside, or was too heavy for proper heat convection. Users had been trained to use lightweight aluminum pots painted black, but they simply chose to use what they had, perhaps as a

Solar cooker construction in the background, and the more traditional wood-fired cookers in the foreground, in Bamako, Mali.



result of their limited financial resources and our inability to follow up.

- In a few cases, the cookers were not properly stored when not in use. Cookers were left outside where animals could damage the glass, or left on the ground where termites could get at the wood, or left under leaks in the roof.

True Test

The dry, hot, and windy Sahelian environment of Mali, combined with a three month rainy season, were elements that truly tested the durability of cooker construction. Of the cookers I observed, the wood (local plywood), cardboard, and metal used in construction held up very well.

The aluminum foil used for reflection did not hold up in this environment. The foil became ripped or dirty, and lost its reflectivity over time. We chose the foil because it was available in-country. Perhaps some sort of imported reflective metal would have been more sustainable.

The ever present harmattan winds created a problem with the lid staying propped open. In many cases the hinges actually fell off the cooker frame. Perhaps a different hinge arrangement, similar to the hardware used on a piano bench, could be used. But this would add to the expense of the cooker. Already each cooker cost about US\$70, about half the monthly income of a middle class family in Mali.

The cookers were limited to uses that depended mainly on cooking time, type of food in the Malian diet, and the time of year. I estimate that approximately 80 percent of the cookers being used were heating water. Very few families used the cookers to cook a full meal. Besides heating water, I found that the cookers had been used for cooking rice, cassava, sweet potato, fish, and bread. My Malian friends Ronna and Wague, who were visiting from Portland, even made a birthday cake in one!

Lessons Learned

Through the cooker project, I found out so much about implementing a small-scale project in a developing country. Here are some of the lessons I learned:

- Phases of the project must be continually tracked by the project originators within the country. It was very difficult to return after one year with limited means, and follow up with individuals and families. We placed fifteen cookers with the US Peace Corps for the express purpose of obtaining follow-up information, along with continuous tracking. They never replied to our numerous inquiries. Other local organizations did not provide follow-up information either.

- The beneficiaries of the project should provide or participate materially in the project. Without materially being involved, there is no incentive to keep up the level of interest or participation in the project. Again we hoped that the Peace Corps and local organizations would assist us here in exchange for the cookers, information, and training we supplied, but they did not.
- Due to limited time and availability of resources to conduct the project, I believe it would have been more effective to focus the project in one area at time. This would have made both implementation and follow-up easier.
- Use of in-country materials for the purpose of attaining sustainability is a useful premise as a guideline. However, a little silicone, or even some more durable reflective material—even if imported—would have helped.
- A faster cooking device such as a parabolic cooker may have found more widespread use, given the fact that in areas where wood is still available, wood cooks much faster than the box design. People generally want new things to work faster and better than existing technology.

Moving Toward Success

The cooker project provided me with such a great opportunity to work with people in my home country, to learn about the use of solar energy projects in developing countries, and to manage project funds. I am glad that we helped begin the education process about solar energy for some of my people, and that we actually provided gainful employment for many of them. I would like to thank Dave Berger, Lloyd Marbet, the Oregon Conservancy Foundation board, and the people of Mali who helped us through the project.

In the end, I would like to thank *Home Power* for sharing our experiences with others. I hope we can learn from each other's mistakes, and that future projects will move from the realm of limited success to that of complete success. Perhaps future projects will include more follow-up evaluation work.

Access

Author: Lanseni Niare, 1736 NE 58, Portland, OR 97213
503-335-3607

Dave Berger, Portland Community College,
9275 SW 8th Dr., Portland, OR 97219 • 503-977-4878
Fax: 503-977-4859 • dberger@pcc.edu

Oregon Conservancy Foundation,
12140 SE Bakers Ferry Rd., Boring, OR 97009
Phone/Fax: 503-637-6130 • cnsrvncy@teleport.com



**New Product
Announcement**

BERGEY XL.1

1000 Watt Home Wind Turbine

Features

- ▶ 5-Year Warranty (Industry's Longest)
- ▶ Maintenance Free Design
- ▶ Excellent Low Wind Performance
- ▶ Nearly Silent Operation
- ▶ Three High-Strength **PowerFlex** Fiberglass Blades, SH 3045 Airfoil*
- ▶ Neodymium Super-Magnet Alternator
- ▶ **AutoFurl** "No Worry" Storm Protection
- ▶ Fail-Safe Design, No Dump Load Required for Structural Safety
- ▶ **PowerCenter** Multi-function Controller
- ▶ **OptiCharge** Regulation for Extended Battery Life
- ▶ Easy Installation with BWC Tilt-up Towers

*Patent Pending

**24 VDC
Battery Charging**



**Available
March, 2000**

The all new Bergey XL.1 is the most technically advanced small wind turbine ever. It combines excellent low wind performance and the legendary Bergey ruggedness, at costs well below the lightweights. It comes from the world's leading supplier of small wind turbines and is backed by the longest warranty in the business. The XL.1 delivers on value.

Compare features, performance, price, reputation, and warranties. The new Bergey XL.1 is the clear choice for your home energy system.

\$1,495

BERGEY • DIRECT

WWW.BERGEY.COM

Or, Call Toll Free:
1-888-669-6178

**Complete AC "Plug
& Play" Systems
from \$2,995**



PowerCenter Controller

- 60A Wind Regulator
- 30A Solar Regulator
- 30A Optional Dump Load
- 24 VDC DC Bus
- Battery Status LEDs

Typical Performance: 5.2 kWh DC per day

4 Times More Energy Than the Air 403¹

1.5 Times More Energy Than the Whisper 900²

1—Air is a registered trademark of Southwest Windpower, Inc.
2—Whisper is a registered trademark of World Power Technologies, Inc.

11.2 mph (5 m/s) Average Wind Speed at Hub Height, Rayleigh Distribution.
Based on manufacturer's published power curves.



SIMPLICITY • RELIABILITY • PERFORMANCE

**2001 PRIESTLEY AVE.
NORMAN, OK 73069
T: 405-364-4212
F: 405-364-2078
SALES@BERGEY.COM
WWW.BERGEY.COM**

Southwest Windpower

full page
four color
on negatives

this is page 52

EASY CHOICES

Solar Cells

AstroPower's high-efficiency five inch and six inch single crystal solar cells are the largest and most powerful solar cells on the market today. With rated power of up to 3.5 watts, these solar cells extend the unparalleled performance history of single crystal silicon into unprecedented new sizes for the best solar cell value around.



PV Modules

AstroPower's PV modules are available with rated power from 30 watts to 120 watts. The perfect solution for applications ranging from remote home power to professional applications such as telecommunications, AstroPower modules carry a 20 year warranty, and are certified to both UL 1703 and IEC 1215 standards.



Large Area Panels

Building a large array? AstroPower's large area panels give you the biggest increment of pre-tested, pre-wired PV power available today – up to 480 watts per panel. Shipped to the site in reusable shipping racks, these panels will get you into production significantly faster and less expensively than using individual modules.



APex™ Technology

Our new APex™ products are made using a revolutionary new continuous high-speed process called Silicon-Film™ that produces wafers in a matter of minutes, instead of days. Unlike many other advanced PV technologies that rely on unproven or toxic new semiconductors, APex™ products are based on crystalline silicon.



The bottom line is lower price *and* peace of mind.

MADE EVEN EASIER.

When you choose a PV supplier, you are choosing not only the products, but also the company behind the products. It's nice to know that your supplier shares the values that brought you into the PV business. AstroPower is uniquely:

Independent; AstroPower is the only major PV manufacturer not controlled by some large multi-national corporation. We have only one business, – your business, the PV business.

Clean; We use silicon wafers recycled from the semiconductor industry to make our single crystal solar cells. This allows us to deliver high quality products while consuming only a small fraction of the energy used by our competitors.

Dedicated; The most focused and dedicated people in the industry work at AstroPower. We work here to make a difference, and we take pride in the company because we all own part of it.

If you would like to join the AstroPower team, please contact us at:



ASTROPOWER
АСТРОПОУЕР

Phone: 302-368-6088 Fax: 302-368-6087
www.astropower.com

Solar-Powered Treehouse

Wade Webb

©1999 Wade Webb

This treehouse is a special passion for Mike, who has taken great care and spared no expense in the basic construction and finish details. With windows, a custom door, and redwood siding, it's a perfect getaway, with a great view of the Rose Bowl's fireworks and the San Gabriel mountains.

Tree & House

The tree is a weeping willow that was planted in 1979. A professional arborist said that this tree is abnormally large for a willow growing in California. Perhaps it has tapped into an underground water source, since it continues to grow like a weed. The tree is about forty feet (12 m) tall and the treehouse platform is eighteen feet (5.5 m) off the ground.

Mike used all recommended methods for securing a treehouse to a tree, including a steel pole to the ground, branch supports, suspension from above by chain, and cantilevered beams angled down to the trunk. The tree is only about forty feet from Mike's home. To build the treehouse, he ran an extension cord from the garage to the tree. When it was finished, he installed a TV, radio, and some lights, and ran them on the extension cord. But he hated having this earthly connection. So he came to us, and we designed a system to take his treehouse off the grid.

Sometimes you have to think outside the box. When Mike Caveney from Pasadena, California came to Solar Webb, we were used to custom applications for our solar electric systems. Since 1995 we have had many people come to us with their special power needs. But this was the first time we had to think about installing a complete solar electric system in a tree!



Mike and the automatic 20 watt halogen light at the front door.



Up the tree, on the roof, with the PV.

The two outdoor lanterns were antique kerosene lanterns that we converted to 12 volt DC. Using the Morningstar SunLight-10 controller, we can have them turn on at dusk and off four to six hours later. The SunLight-10 is so versatile that the customer can choose from many settings for lighting control.

We installed an on/off switch on the Portawattz 300 inverter so that when the family isn't in the treehouse watching TV or listening to the radio, they can keep the inverter off to conserve energy.

Sanctuary

When the sun goes down, the two lanterns on the treehouse deck come on. The glow that they throw onto the treehouse is just beautiful. The house has been featured on *About Your House* on PBS and in a special on craftsman style homes on *Home and Garden TV*. There is talk of using it as a location for a kids TV show. The solar electric system is working perfectly and is a natural addition to Mike's treetop sanctuary.

Access

Author: Wade Webb, Solar Webb, Inc., 136 E. Santa Clara St. #6, Arcadia, CA 91006 • 888-786-9322 or 626-447-9710 • Fax: 626-447-7984
info@solarwebb.com • www.solarwebb.com

Treehouse owner: Mike Caveney
Caveney@aol.com

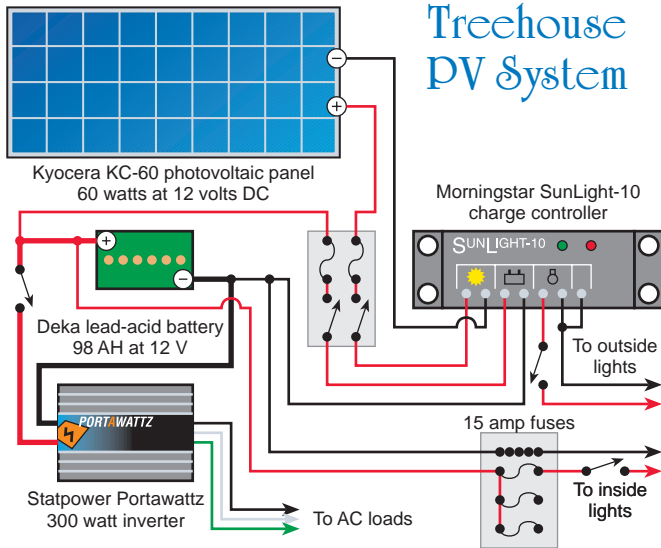

PV & Wiring

First we installed the 60 watt Kyocera PV module on the treehouse roof, which gets lots of morning and afternoon sun. We did clear a few branches to improve the solar exposure. There is a closet inside the treehouse which has plenty of room for the battery, charge controller, DC fuse box, safety shutoff, and inverter. The wires from the PV run down the back side of the house, under the platform, and up through a hole into the closet.

Mike prewired the treehouse for two AC outlets and one inside light. We were able to provide 110 VAC to the outlets and 12 VDC to the low voltage light inside the house. The indoor lights were purchased at the local swap meet, and were just fixtures with no electrical components in them.

Treehouse System Costs

Item	Total Amount
Kyocera KC-60 60 watt module	\$335.00
Labor	\$270.00
Deka 12 volt 98 amp-hour battery	\$150.00
Morningstar SunLight-10 controller	\$116.00
Two custom DC outdoor lights	\$100.00
Statpower Portawattz 300 inverter	\$90.00
Sales tax	\$87.53
Custom DC indoor light	\$50.00
Roof mount kit	\$33.00
Battery box	\$25.00
Todd low voltage fuse box	\$20.00
Square D DC safety disconnect	\$20.00
Three light switches with box	\$15.00
Module connect cable	\$13.00
Total	\$1,324.53

Take the Guesswork Out of Power Measurement



Things that Work!
Home Power #67



Richard Perez, in his review of the 4-1850 Brand Digital Power Meter for *Home Power*, said, "This is the first time that I have wished for more than two thumbs, 'Both Thumbs Up!'"

BRAND DIGITAL POWER METER

Brand Electronics manufactures digital power meters that are easy to use, reliable, accurate and affordable

- Measures overall power consumption and cost of operation.
- Use to measure 117 VAC circuit loads up to 1850 watts and determine sizing requirements for backup power supplies and circuit protection.
- Make informed decisions regarding:
 - System sizing,
 - Appliance selection and replacement,
 - The use of equipment in standby mode,
 - Energy reduction methods.

Model 4-1850 displays:

Watts, kW-hrs, User Cost, & Average Monthly Cost.

Model 20-1850 and **20-1850CI** displays:

Watts, kW-hrs, User Cost, Average Monthly Cost, Amps, Volts, Power Factor, Vars, V-A, & Peak Watts.

Model 21-1850CI is a data logging unit. It has Model 20 capability plus on board memory to accumulate data over prolonged periods for download to computer.

Price: 4-1850:	\$149.95
20-1850	\$249.95
20-1850CI	\$299.95
21-1850CI	\$349.95

Price includes domestic shipping and handling.

CI = Computer Interfacing: includes RS-232 interface, cable and software.

Maine residents add 5.5% sales tax.

I'm very impressed with this meter. I've learned a lot about my appliances. Some that I thought used a lot of electricity, didn't. Others were just the opposite. The meter and software work exactly as represented. What a novel concept!...

This has been one of my best purchases! I've learned a great deal and thought I'd give you a well deserved "pat on the back".... Thanks!

—John R. Grau, President, Affordable Electric Inc

Interestingly, both Bob and I have personal meters we use on site evaluations and I can never hang on to mine for more than a week. I keep selling it! We also allow customers to leave a deposit equal to the sale price and take the meter home to test their appliances. So far everyone has called back to let us know they wanted to keep the meter.

—Ray Ogden, Energy Outfitters

Brand Electronics ships customized units on a routine basis. We welcome an opportunity to discuss your power measurement applications; AC or DC; any voltage, current, or plug configuration.

See our web site for additional product specifications and information on availability of new products.

Dealer inquiries:

atkinson@brandelectronics.com

Tel/Fax: 207-737-3474

Call today! To order, call toll free 24 hrs.



1-888-433-6600

<http://www.brandelectronics.com>

Brand Electronics

421 Hilton Rd., Whitefield, ME 04353

For information only, call 1-207-549-3401

email: info@brandelectronics.com

SOLAR-ONE™ TECHNOLOGY AT WORK: THE HIGH UTILIZATION POSITIVE PLATE

Innovative technology is what separates Solar-One™ from the rest of the pack. Delivering full capacity for more total cycles than conventional batteries, Solar-One batteries are engineered for outstanding performance, from the inside out!

A Take a close look at the Solar-One unique high-utilization positive plate, and you will see that it is our positive grid that provides the foundation for Solar-One Positive Plate Technology. Incorporating the highest quality raw material available in the industry. The Solar-One grid uses our own metallurgical formulation and a computer-controlled grid casting system, another industry exclusive! The result:

B the Solar-One grid contains larger lead crystals, and larger crystals mean fewer points for corrosion to attack the battery.

C To accommodate grid corrosion and growth, many battery manufacturers are forced to use a "floating seal", a battery design which is far more subject to leakage than the Solar-One's burned post-to-cover seal. Having controlled the growth of our positive grid, the Solar-One seal is stronger and less vulnerable to leakage.

D The key to Solar-One's

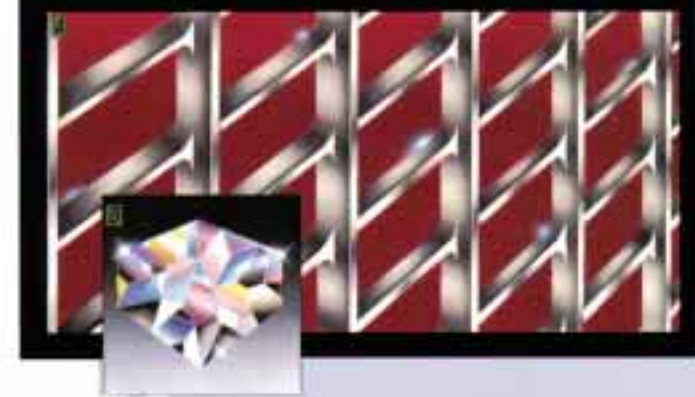

tradition of longer battery life at full capacity is our patented H.U.P. technology (US patent #4,135,829). H.U.P. is a process which optimizes both the active material utilization and the longevity of the positive paste. A colloidal suspension of

tetrafluoroethylene (Teflon®) is added, at precisely measured volume, temperature, and time, to the paste mix and causes the formation of a pervasive network of fibers throughout the active material.

E This process known as fibrillation, locks the active material into place and virtually eliminates flaking and shedding - the chief causes of battery failure.

F Tested at the National Battery Testing facility batteries with H.U.P. have been shown to increase working life by at least 20%, with absolutely no sacrifice of capacity! In fact, H.U.P. batteries deliver full capacity longer, have faster voltage recovery with lower internal resistance, and last longer than conventional batteries. For more power in your Renewable Energy System look for the H.U.P. Solar-One™ label. High Utilization Positive plate technology only from:



The First Name In R-E Batteries

Visit our **NEW Store!**

6791 South Main St.
Suite C

Bonnars Ferry, ID 83805

800-718-8816

208-267-6409

fax: 208-267-3973

www.nwes.com

email: batteries@nwes.com



Dealer Inquiries Invited.

- Warranted for 2100 cycles at 80% depth of discharge •
- FREE Shipping in 48 states •
- HUP Technology Patented in 1982 •
- ISO 9000 Certified •

Now you can enjoy the benefits of the Proven Hup Technology in your R-E system with the Hup Solar-One. Best Factory Warranty: 5 years Free Replacement, 5 years Pro-rated.

FREE System Design and Product Catalog for all your alternative energy needs!
Special Pricing on Package Systems / Best Pricing & Customer Service is our Goal

Check our ONLINE CATALOG at WWW.nwes.com

GOH SOLAR ONE!
NORTHWEST ENERGY STORAGE
800-718-8816

The Highest Efficiency Terrestrial Silicon Solar Cell You Can Buy

John Perlin

©1999 John Perlin

Ever since the first silicon cells were developed, the biggest problem has been grabbing the energy from the cell and getting it to the electrical load. This has been the stumbling block since the beginning of solar cell research and development. The buried contact cell is providing the best solution yet.

Contacts

Without electrical contacts somehow adhered to a solar cell, the cell is useless, no matter how well it's put together. The contacts extract the electricity generated by the sun, and wires connected to the contacts carry it to the electrical loads. In the 1970s, solar pioneer Bill Yerkes and colleagues streamlined production of solar modules. They began screen printing contacts onto the front surface of cells to cut costs. Ever since then, most manufacturers of photovoltaic (PV) cells have followed suit. The process resembles the method used to put designs on T-shirts.

Arthur Rudin, Director of Product Marketing at Siemens Solar, explains the procedure: "You have a screen, you put your shirt under it, the screen has a pattern, and you move a squeegee with paint across the screen. With solar cells, the paint happens to be a mix of silver paste with glass. The concoction is a good conductor and bonds well with cells."

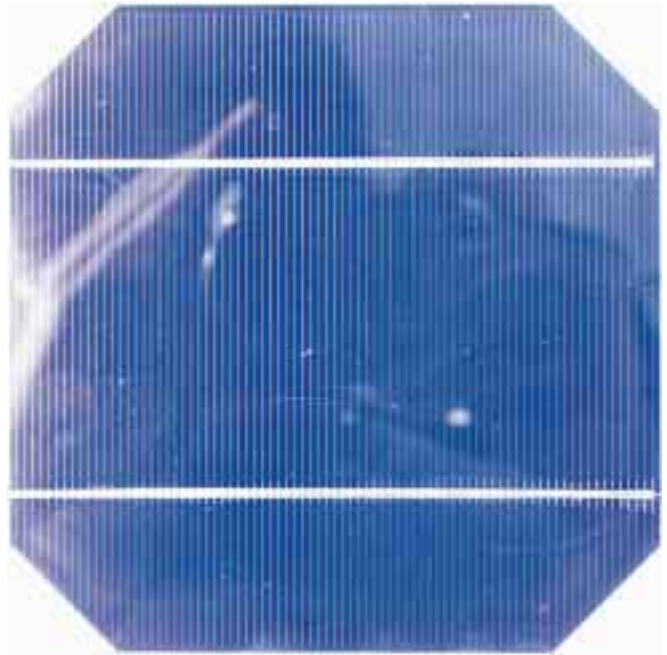

A laser-grooved photovoltaic cell.

The rest of the industry seemed quite satisfied with the screen-printing approach, and adopted the process. It readily lends itself to assembly line production, and definitely proved more economically sound than earlier methods. But Dr. Martin Green and colleagues at the University of New South Wales in Sydney, Australia, took a different position. In the early 1980s, Green and his co-workers were also focusing their attention on improving the efficiency of single-crystalline solar cells.

They had witnessed the failure of cell developers to lower the price of solar cells. The attempts had centered on developing a new PV material that would circumvent the very expensive slicing step necessary for making crystalline cells. The Australians decided instead to look at ways to substantially raise the efficiency of cells after the cutting process, without increasing manufacturing costs. This would provide more watts per dollar, achieving the same goal.

Cutting Edge

It was no accident that Australia fostered such cutting-edge research in terrestrial photovoltaics so early in the history of the technology. By the mid 1970s, Australia had become a hotbed of activity in PV research and development. The national Australian telecommunications provider, Telecom Australia (now Telstra) had decided to power much of their remote equipment—including rural telephones and microwave networks—with solar cells.

In fact, in the early 1980s, Solarex cited Telecom Australia's mass use of PV as primary "to the

development of solar power as a practical energy source.” Green applauds them for their commercial commitment to solar cells, and for helping him and his colleagues develop one of the premier PV research centers in the world. “It obviously stimulated our work because we had a target audience. There was a real interest by the Telecom people in actually using these things.”

Green and his colleagues meticulously examined the solar cells that were being used in the 1970s and early 80s. They came to the conclusion that the performance of commercial crystalline silicon modules “hinged on how metal contacts were formed to the cell.” That became their focus.

Green’s group discovered that although screen printing lowered production costs, it was the chief obstacle to better cell performance. The Australians found that the additives in the silver paste that make screen printing possible are less conductive than pure silver. They significantly reduce the contacts’ ability to effectively capture the electricity generated by the cell.

One might suggest an increase in the number of contacts on the cell to compensate for the loss in efficiency. But more of the relatively wide contact lines produced by screen printing would shade too much of the cell from the sun. The only way to get a sufficient amount of electricity out of the cell to the silver-paste contacts has been to flood the surface of the cell with phosphorous. Unfortunately, this creates a dead layer on the cell’s surface. Light absorbed in this inactive region is wasted since it cannot generate electricity.

Laser Grooves

The Australians hunted for another way to lay the contacts in order to avoid the pitfalls inherent in screen printing. In their search, Green and his colleague, Dr. Stuart Wenham, “hit upon the idea of using a laser to form grooves on the surface of the cell” and filling the grooves with copper. The copper contacts have three times the conductivity of silver paste, and since they are partially buried inside the grooves, they obscure less of the cell’s surface.

This allows more sunlight to reach the cell, and also permits the cell builder to place more contacts on the cell without worrying about shading. Enough contacts can be added to eliminate the need for all that phosphorous, allowing the entire piece of PV material to respond to light. Green and his colleagues named their invention the “buried contact cell.” Cells made this way have consistently outperformed all others in the world.

The Australians’ ultra-efficient cells got their first test in the 1990 World Solar Challenge, where PV-powered



A screen-printed photovoltaic cell.

vehicles raced across the Australian continent. The Japanese contender—the clear favorite—was a Honda powered by modules rated as the best in the world. However, a Swiss car, which ran on the Australians’ buried contact cells, unexpectedly won by a wide margin, proving its achievement was no fluke. The lopsided victory attracted worldwide attention to the work done by Green and his colleagues.

Buried Contacts

As one of the fruits of the Australians’ triumph, British Petroleum (BP) purchased the rights to manufacture the buried contact cell. Currently, BP makes modules in Spain using the buried contact concept. The company takes a crystalline wafer 300 microns thick and digs V-shaped grooves 20 microns wide and 40 microns deep into each cell. Then technicians plate the copper contact into this groove.

The laser-grooved cells now on the market convert between 16 and 17 percent of the incoming sunlight into electricity under peak conditions—full sunlight with the rays falling perpendicular to the module. Under similar conditions, screen-printed cells change between 13 and 14 percent of the sun’s energy into electricity. Laser-grooved cells improve peak performance by about 20 percent.

Low Light Performance

In less than ideal conditions during early morning, late afternoon, and on cloudy days, the efficiency of the laser-grooved product drops by only 13 percent. Its screen-printed rivals fall 35 percent off peak efficiency.

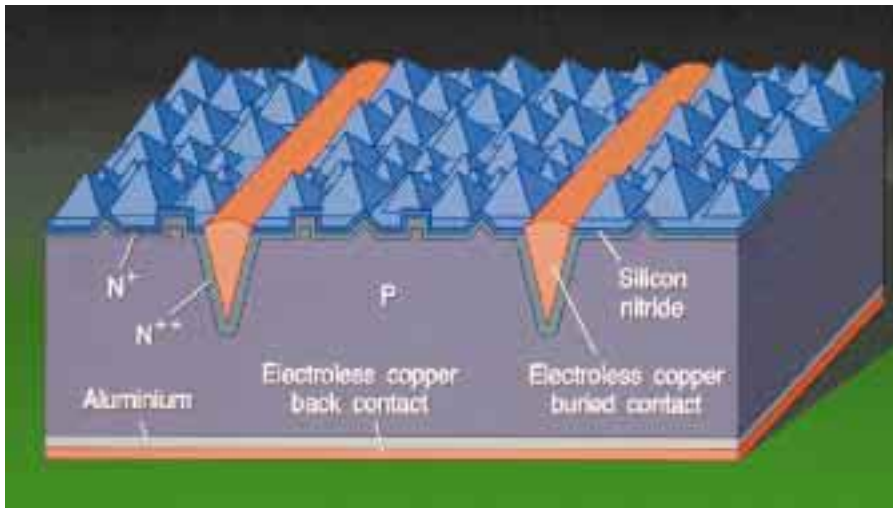

A cross section of a laser-grooved buried-contact PV cell.

In other words, under less than ideal conditions, the buried-contact cell is better than the screen-printed cell by nearly 30 percent. People living in the Pacific Northwest, Northern Europe, and other places prone to low solar insolation levels should take note!

The significant difference in the two technologies' generation of electricity under less than perfect solar conditions has led to a change in how a cell's energy efficiency is measured. The goal is to more accurately rate a module's performance for a specific location. For many years, cells have been ranked by their peak watt efficiency. It now seems preferable to examine the cells' true energy output, letting people know how much energy they will really get.

Thin Film

BP has been commercializing the buried contact cell for crystalline wafers. Meanwhile, Martin Green and his colleagues have taken laser grooving one step further to pioneer a thin-film crystalline silicon cell that may someday lower the price of solar cells dramatically.

Actually, the Australians had always yearned to work on thin-film cells. But money constraints forced them to concentrate their efforts on thick, conventional crystalline silicon. Their financial situation improved dramatically after the solar car race victory and BP's purchase of the rights to manufacture the buried contact cell. These two significant achievements led the Australian government to award Green and his colleagues a research center with generous funding.

Now they can concentrate on their dream: building a highly efficient thin-film crystalline silicon photo-voltaic device that will be cheap enough to provide a large fraction of the world's power. A thin-film cell would lower

production costs considerably because it would avoid the wasteful process of cutting large pieces of crystalline silicon into wafers, and would use much less silicon.

Laser grooving is the key to the design of this new cell, now in pilot production, and planned to be commercialized by 2003. First, very thin alternating layers of positive and negative polycrystalline silicon are deposited onto glass. All potential electrical charges are near a p-n junction—the core of any solar cell, where the important photovoltaic activity occurs. Grooves that are laser-cut into each stratum and filled with metallic contacts collect the

electricity generated in each layer of the cell when exposed to sunlight.

Time Will Tell

Pacific Power, the largest utility in Sydney, Australia, where Martin Green and his team are based, has generously funded their efforts. They have lured some of the best people in the crystalline silicon cell field to help move toward the commercialization of the laser-grooved buried-contact thin-film cell. Only time will tell if this bold application of the laser-grooved buried contact will bring about the ultimate solar generator—a low cost, highly efficient solar cell.

Access

Author: John Perlin, 1809 Hillside Rd., Santa Barbara, CA 93101 • 805-687-0160 • Fax: 805-966-1344

Professor Martin Green, Photovoltaics Special Research Centre, University of New South Wales, Sydney, NSW, 2052, Australia • 61 2 9385 4018 Fax: 61 2 9662 4240 • M.Green@unsw.edu.au www.pv.unsw.edu.au

Pacific Solar, 82-86 Bay St., Botany, Sydney, NSW, 2019, Australia • 61 2 9316 6811 • Fax: 61 2 96664079 info@psolar.com.au • www.pacificsolar.com.au

Portions of this article are excerpted from the new book *From Space to Earth: The Story of Solar Electricity*, by John Perlin. US\$32 from aatec publications, PO Box 7119, Ann Arbor, Michigan 48107 • 800-995-1470 or 734-995-1470 • Fax: 734-995-1471 aatecpub@mindspring.com



CHINA DIESEL IMPORTS

OWN YOUR OWN
DIESEL ELECTRIC
COMPANY

THE LEADER
SINCE 1977 IN
DIESEL POWERED
GENERATORS,
TRACTORS AND
MARINE ENGINES.
ALSO SPECIALIZING
IN INVERTERS,
WIND AND SOLAR
ELECTRIC POWER



SPECIAL

**25 hp 4 X4 DIESEL
TRACTOR \$5995.⁰⁰**

Back Hoe &
front end loader
Models
also available

Call or E-Mail 24 hrs / 7 days a week for FREE color literature 1-800-341-7027

Cdi@chinadiesel.com Visit us at WWW.chinadiesel.com

Or write to: China Diesel Imports, 15749 Lyons Valley Rd., Jamul, CA 91935

Warning!! Do not be fooled by "Here today, gone tomorrow" imitators. We have no dealers or distributors, we sell only direct.



More
Power!



Get All The Power You Paid For!

Solar panels...You bought them, and they were expensive.
But are you getting the power you paid for? Be certain with
the state-of-the-art **Charge Controllers from Fire, Wind and Rain!**

The Power Advantage series of charge controllers features include...

- Maximum Power Point Tracking: Continuously adjusts current from solar panels as it transforms voltage, allowing it to seek the precise point where maximum power is available. This produces up to 25% more power than conventional models.
- 3 Charging Modes: Bulk charge, constant voltage and equalize.
- Easy To Use: Set up with built in LCD display or computer (depending on model). Our exclusive Virtual Control Panel lets you monitor your system and collect data on how much energy has been produced and used, and the state of charge of the battery as well as battery life based on present load.
- Available in 24 and 48 volt models with capacity up to 1500 watts. Also available in both step up and step down voltage models. Ideal for retrofits! Any installation using a conventional charge controller can use a Power Advantage!

To be sure your getting all the power you paid for, we invite you to contact us or the Dealer in your area.



FIREWIND&RAIN
TECHNOLOGIES LLC

3920 East Huntington Drive, Flagstaff, AZ 86004
(800) 588-9816 • (520) 526-1133 • Fax (520) 527-4664
www.firewindandrain.com

WE'VE PUT THE POWER... ON YOUR DESKTOP

POINT, CLICK, LEARN, DESIGN, ANALYZE,
COMPARE, AND BUY WISELY.

NO ENGINEERING DEGREE REQUIRED!

BERGEY • DIRECT

Contents

- About Bergey
- Latest News
- 90 Second Expert
- Tutorials & FAQ's
- Products & Services
- Value Packages
- Wind Maps
- Feasibility Study
- Economics Study
- System Design
- Purchase Options
- On-line Ordering
- Certified Dealers
- Resellers
- Tech. Manuals, Etc.
- Installation Process
- Search the Site
- Library & Links
- Jobs & Opportunities

MAKING A DIFFERENCE

BERGEY WINDPOWER

Clean renewable power for homes, villages, farms, and remote sites

Bergey Windpower is the world's leading supplier of small wind turbines. We were established in 1977 and now have installations in all 50 U.S. States and over 90 countries. We take pride in offering products that let homeowner's run their utility meter backwards or that can bring electric power and modern services to remote areas.

SIMPLICITY • RELIABILITY • PERFORMANCE

"How can we help you today?"

Mike Bergey
President & CEO

- I want to learn about the California and Illinois Rebates
- I want to learn more about wind power
- We want to reduce our utility bills
- I hate my power company
- I need power for a remote home or village
- I want to help the environment
- I need reliable power for a communications site
- I need power to pump water for drinking or crops

WWW.BERGEY.COM



SIMPLICITY • RELIABILITY • PERFORMANCE

**2001 PRIESTLEY AVE.
NORMAN, OK 73069
T: 405-364-4212
F: 405-364-2078
SALES@BERGEY.COM
WWW.BERGEY.COM**

The Slipstream Electric Bicycle



William A. Gerosa

©1999 William A. Gerosa

The Slipstream hits 30 plus mph—we suggest wearing a helmet.

We have been powering one bedroom and the basement of our house for about two years using solar energy. From March through October, the PV panels produce more power than we can use. I began to wonder if we could take this extra power and charge batteries for an electric bike.

From this start, the Slipstream evolved. The Slipstream is a converted, electric-powered mountain bike that can be used to carry a rider easily for short trips of 5 to 20 miles (8–32 km). It has exceeded all of our expectations, and has now logged over 1,500 electric miles (2,414 km). People are consistently amazed at the speed and acceleration of this bike.

The Chosen Bicycle

Because we planned to add 55 pounds (25 kg) to a bicycle, strength was an important consideration. We selected a Fuji Mountain bike for this reason. With a steel frame (as opposed to aluminum or carbon fiber) and strong brakes, this bicycle was a good choice. I decided on a smaller 18 inch (46 cm) frame to keep things tight and low to the ground.

Afterwards I learned from my local bike store owner that I had mounted the 17 pound (7.7 kg) motor at the weakest point of the entire frame. But there is not really a better position, and I have not had a single problem.

The Slipstream handles extremely well and has a nice, strong feel to it. Safety is of paramount importance because the bike can travel at speeds in excess of 30 mph (48 kph).

Strip It Down

The conversion is a relatively simple process, but it requires time and attention to detail. The bicycle needs to be stripped of all derailleurs, the chain, pedals, and cranks. The axle that the cranks and pedals connect to is left intact. The Slipstream hardware is then added one component at a time.

Check to make sure that the wheels are in good shape. If the wheels have loose spokes or have side to side wobble, they might need to be adjusted. The headset (bearings in the front fork) must be properly tightened. If it is too tight or too loose, the joint can weaken, and it has the responsibility of carrying a substantial amount of weight.

Motor & Drive Train

The motor is a fine piece of equipment manufactured by Scott Motors, Inc., available from KTA Services. It is a 1 horsepower permanent magnet DC motor designed for 24 volts. It weighs approximately 17 pounds (7.7 kg) and is worth every nickel of the US\$260 purchase price.

The motor is the most critical element of any electric bicycle. I tried to cheat using US\$15 and \$20 winch, starter, and other motors. Don't follow my lead. These motors are not continuous duty and will prove to be very inefficient. The Scott motor will ensure that you

have more than ample power. It will give you more miles out of your bike for the energy you put into the battery. It is also only slightly warm after one hour of use. Some motors I tested became extremely hot, which is a sign of their low efficiency.

The motor is mounted right behind the front wheel under the down tube, which runs from the head (or front) tube down to the cranks. I used two 6 inch (15 cm) L-brackets to secure the motor to the frame. The brackets are bent in a vise to a 120 degree angle.

I designed a two-step drive train to get the 8.4 to 1 drive ratio I was looking for. This ratio is a nice balance between top end speed and low end torque for decent acceleration. A direct drive would have required too large a gear on the rear wheel. The cranks are replaced with a 20 tooth sprocket on the left side of the jackshaft and a 13 tooth sprocket on the right side of the jackshaft.

A 60 tooth gear is bolted to the the existing cassette sprocket on the rear wheel. A #35 roller chain runs from the motor to one side of the crank axle. Another #35 roller chain runs from the other side of the crank axle to the large sprocket. I purchased the sprockets from Northern Tool & Equipment, and the chain from Surplus Center.

Batteries

The batteries are two 28 amp-hour 12 volt sealed gel cells, wired in series for operation and parallel for charging. They are available from Mouser Electronics and are made by PowerSonic. The PowerSonic battery line has performed well for the Slipstream. These are deep cycle batteries that can withstand deep discharge. They hold up to the demands of a motor that can ask for over 1.5 horsepower worth of juice, or about 1,125 watts (roughly 47 amps at 24 volts).

The batteries hang just under the top tube of the bike, between the rider's legs. They are wired to the motor controller and the motor using heavy duty, zero gauge (53 mm²) welding cable. Using heavy cable provides a nice wide path for amperage to run through, and lessens any voltage drop that would occur through a smaller cable.

The usable lifetime of these batteries is highly dependent on two things—your style of driving and the way you charge and maintain the batteries. Rapid starts and extended

maximum speed will, over time, destroy the batteries. Using a charge controller set to 14.0 volts will be gentle on the batteries. Charging the batteries up before they fall below 50 percent charge will also extend their life.

Throttle & Motor Controller

The throttle is a Domino Throttle Grip that is basically a nice, clean looking 5 K Ω potentiometer that drives the motor controller. The motor controller is a 24 volt DC 175 amp unit made by Curtis PMC, and is mounted just forward of the batteries. It is based on MOSFET technology and simply varies the ratio of the *on* pulse to the *off* pulse.

When you are going slow, the *on* pulse is very short compared to the *off* pulse. When going fast or demanding more of the motor, the *on* pulse is long compared to the *off* pulse. This switching occurs at 15 KHz. The efficiency is around 98 percent, according to the manufacturer. This motor controller is truly a quality piece of equipment and provides smooth, even power to the motor across the entire throttle range. Both products are sold by KTA Services.

The "Gas Gauge"

Anyone who has used an electric vehicle for any period of time becomes very attached to it and learns all its idiosyncrasies. This includes developing a sixth sense for when the batteries are almost out of juice and exactly how far the EV can go on the remaining charge.

However, there are times when a more objective measure of the battery's state of charge is needed. Maybe your last charge wasn't truly complete, or perhaps that wind chill factor is stealing a little more power than you thought as you zip along at 20 mph (32 kph) in 30 degree (-1°C) weather. Nothing is more

A simple yet high-performance home-built EV.





Drivetrain from the 1 hp motor to a 20 tooth sprocket on the bottom bracket spindle.

unsettling than feeling that telltale drop in the motor's power when you still have five miles (8 km) to go.

There are several rather fancy meters on the market that collect and display power data in many different formats. I decided on a US\$5 voltmeter from Mouser Electronics. Though it is a 12 volt meter, you can double the range by using a resistor, which means that a 12 volt reading on the meter is really a 24 volt reading. This is an inexpensive alternative to paying US\$200 for a high tech meter.

By keeping an eye on the voltage reading, it's easy to see approximately how much energy is left in the batteries. An alternative is to carry a digital multimeter with you and check the voltage at key times during your journey.

After a while, I developed a mileage comfort zone. I knew that I could always, even under the worst circumstances, go 15 miles (24 km) without a hitch. Twenty was fine also, but anything approaching 25 or 30 miles (40–48 km) between charges required vigilance.

Drivetrain from the 13 tooth sprocket on the bottom bracket spindle to the 60 tooth sprocket on the rear hub.



Charging

The Slipstream may be charged from solar panels, from an AC charger, or from the main house battery bank. In each case, the power flows through a portable charge controller that makes sure the bike's batteries are gently recharged. I have a heavy duty cable with alligator clips for normal riding use in series, and a set of jumper cables for paralleling the batteries when I charge. My only DC source is the solar panels I have at home. I also carry a cigarette lighter plug adapter to charge from a car, but I have never used it.

The charge controller is a small, 12 volt DC 8 amp unit that is set for 14.0 volts and built into a Radio Shack project box. A 5 amp meter is affixed to the front of this project box and wired in series with the charge controller. This meter shows the amperage into the batteries through the charge controller. It gives an indication of how hungry the batteries are and how much power your charging source is creating relative to the batteries' demands.



The Scott Motors 24 VDC PM motor and two PowerSonic 28 AH batteries can drive this bike to 30 mph.

The Slipstream requires about 65 amp-hours to completely recharge a fully depleted battery bank. When the solar panels are also powering a portion of our home, the bike can be fully recharged in about 10 to 20 hours of fairly strong sunlight. If the house demands no solar electricity, these figures can be cut in half.

Being a pragmatist, I also devised an AC charging unit for the bike. It is simply a 120 VAC to 15 VDC surplus power supply. I bought it from Mouser Electronics, and it provides the Slipstream with 5 amps at 14 volts. This is extremely handy for longer treks that are beyond the normal range of the bike. I carry the ammeter/charge controller and the power supply in a backpack when I ride. Both are small and add no weight, and I can charge anywhere there is a 120 VAC outlet. Gas station owners are usually more than happy to let stranded EV motorists "plug in" for 15 minutes while buying a soda.

Performance

After they understand that the Slipstream is electric-powered and charged by the sun, most people begin asking why the bike was built this way or that way. There is no correct way to build an EV—it simply has to suit your needs. I needed an EV that had the flexibility of a small, light vehicle coupled with decent range and performance capabilities that would allow the rider to negotiate limited automotive traffic.

As of July 1999, the bike has traveled over 2,400 miles (3,860 km). It has seen 95 degree (35°C) days and it has seen 15 degree (-9°C) days—not including wind chill factor. While 20 mph (32 kph) is a comfortable cruising speed, the Slipstream is capable of 30 mph (48 kph) on flat ground and 20 mph up steep grades. It consistently beats cars off the line at stoplights and can jump to 30 mph in about four seconds from a standstill.

Feel free to visit the Slipstream Web site, which features some additional information on the bike and some of our latest EV projects. Please send me email if you have specific technical questions about construction that this article did not cover. Happy EV-ing!

Access

Author: Bill Gerosa, The Electric Bicycle Project,
134 Palmer Ave., Sleepy Hollow, NY 10591-1616
212-559-4034 • gait@earthlink.net
<http://home.earthlink.net/~gait/emb.htm>

KTA Services Inc., 944 W 21st St., Upland, CA 91784
909-949-7914 • Fax: 909-949-7916 • www.kta-ev.com

Mouser Electronics, 11433 Woodside Ave., Santee, CA 92071 • 800-346-6873 or 619-449-2300
Fax: 619-562-8796 • sales@mouser.com
www.mouser.com

Northern Tool & Equipment Company, PO Box 1499,
Burnsville, MN 55337 • 800-533-5545 or 612-894-8310
Fax: 612-894-0083 • hal@northern-online.com
www.northern-online.com

Surplus Center, PO Box 82209, Lincoln, NE 68501-2209 • 800-488-3407 or 402-474-4055
Fax: 402-474-5198



- POWER LEVELS FROM 1KW TO 60KW
- OUTPUT VOLTAGES OF 100,120,230
- INPUT VOLTAGES OF 12 TO 108
- 20+ YEARS MTBF
- EXPANDABLE
- MODULAR
- REMOTE CAPABLE
- "HOT" SWAPABLE



TRUE SINE WAVE MX SERIES POWER INVERTERS

COMING SOON
BATTERY CHARGERS



2225 E. LOOP 820 N. FT. WORTH, TEXAS 76118-7191
TEL: 817.488.4443 VOICE: 817.488.4069 FAX: 817.488.1284
WEBSITE: WWW.EXELTECH.COM E-MAIL: INFO@EXELTECH.COM



**LOOKING FOR
1000+ AH?**

Now Shipping!

4-KS-21PS
1104AH (20 hour rate)
15 3/4 (L) X 9 3/4 (W) X 24 3/4 (H)
230 lbs (wet), 186 lbs (dry)

INTRODUCING... THE NEW 4-KS-21PS

- New Generation Dual-Container Modular Design
- 3300 Cycles to 50%DOD.
- Fewer or No Parallel Strings
- Fewer Cells
- Less Maintenance
- Elimination of Stray Current
- Greater Charging Efficiency
- Available Wet or Dry Charged
- 10 Year Warranty



Surrette Battery
Company, Ltd.

1-800-681-9914
sales@rollsbattery.com

Rolls
Battery Engineering

Vanner

four color on negatives

7.125 wide
4.5 high

plug into

POWER



FROM THE SUN, WIND & WATER

We're Your Resource for Home Power Equipment.



Call us for ONE STOP SHOPPING from our HUGE IN-STOCK INVENTORY. We're the #1 TRACE DISTRIBUTOR in the US with over 20 YEARS IN THE BUSINESS of serving you with GREAT CUSTOMER SERVICE. Our FREE TECHLINE is staffed by MECHANICAL and ELECTRICAL ENGINEERS. **CALL FOR OUR CATALOG: 1-800-777-6609.**

Dealer
Inquiries
Welcome.



Applied Power, formerly known as
**Alternative Energy
Engineering**

Solar, Wind & Hydroelectric Power Systems

Things That Work

Tested by Home Power

RV Power Products' Solar Boost™ 2000

Tested by Sam Coleman,
with help from Joe Schwartz

©1999 Sam Coleman

The Solar Boost 2000 is a 20 ampere, 12 volt, temperature-compensated, pulse width modulated charge controller for use in any small PV system. It has a special current boosting function, which uses peak power point tracking to give you more current into your batteries without adding additional panels.

Other features include an output current limit of approximately 21 amperes (even if the input is overloaded), a relay instead of a blocking diode, and reverse polarity protection on the battery and PV connections.

RV Power Products, as their name implies, has primarily focused on the recreational vehicle market. But with this product, they are moving into the renewable energy field as well. A similar controller for larger systems has just been introduced. It will handle 12 and 24 volt systems of up to 50 amps maximum charge rate.

Installation & Setup

This controller has an open frame construction and is meant to be flush mounted in a box or in the front of an enclosure. Open frame means that there is no back cover, and the electronics are exposed. There are four mounting holes for screws on the unit. When installing, make sure that you have easy access to the dip switches and adjustment potentiometers, since fine-tuning will be necessary after the initial installation. RV Power Products also offers an optional US\$25 surface mounting box.

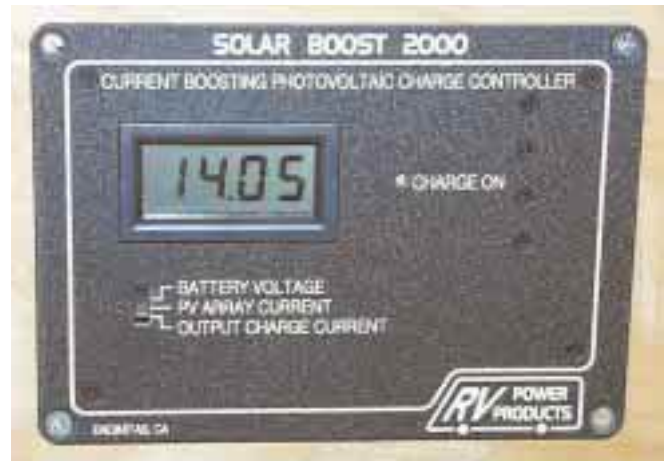

The Solar Boost 2000 faceplate.

The installation and initial setup are fairly simple. The instruction booklet is clear and informative. There are only five wires to connect—two to the PVs, two to the batteries, and the temperature compensation lug, which is connected to a battery terminal. To set up the unit, you use eight dip switches, a battery setpoint potentiometer, and a peak power point potentiometer. The instructions for installation, initial setup, and fine-tuning are relatively easy to follow. Our test system was fine-tuned twice before actual data was taken.

Testing

The Solar Boost 2000 was tested in a system with approximately 165 watts of PV and a 210 ampere-hour sealed 12 volt battery pack. The PV array consisted of three different type modules with widely varying peak power points. One of the peak power points was rather low, with a less than ideal temperature response. This configuration is the worst case scenario, since the peak power point of the combination was closest to the lowest individual value.

The percentage of current boost is affected by a variety of factors. The most important factors are temperature and battery voltage. The lower the temperature of the panels or the voltage of the batteries, the higher the boost. At the same ambient temperature, panel temperature can be affected by solar insolation, wind and breezes, moisture, clouds and cloud effects, and the length of the solar day. Another factor is wiring—both wire size and connections. To maximize the unit's current boost capability, voltage drop between the PVs and batteries should be kept to a minimum.

The graph shows the percentage of current boost versus ambient temperature. Variations at the same or similar temperatures are due to the battery voltage and the other factors cited above. The battery voltage range during data acquisition was between 12.78 and 14.17

VDC. Maximum boost was 21.1 percent and occurred at a temperature of 32°F (0°C) with a battery voltage of 12.97 VDC. The peak power point varied from 13.41 VDC at 85°F (29°C) to 16.65 VDC at 40°F (4°C).

At the lowest battery voltage, current boost was 19.0 percent at of 36°F (2°C). At the highest battery voltage, current boost was 9.6 percent at 66°F (19°C). The average power transfer efficiency between input and output was 95.9 percent.

At high temperatures and battery voltages, the boost percentage can go slightly negative since power transfer is never 100 percent efficient and the device itself uses some current. But when the batteries are full and there is plenty of sunshine, this is not really a disadvantage, since the systems are running a surplus anyway.

Conclusions

The manual for the Solar Boost 2000 says that you may get up to 30 percent or more current boost. Even with a much less than ideal set of PVs, I measured a maximum boost of 21.1 percent. Also, the wiring in the test system was smaller than it should have been. Without these drawbacks, it is highly probable that I could have measured 30 percent boost at even lower temperatures and voltages. With a set of PV panels of similar type and consistently higher peak power point, along with better wiring, this 30 percent figure probably could have been achieved.

Typical power conversion efficiency is rated at 94 percent at 15 amps. The average measured during the test exceeded this value, although current was somewhat lower.

The Solar Boost 2000 is not only an effective maximum power point tracker, it is also an excellent charge controller. The temperature compensation for maximum charging voltage works perfectly, both below and above the reference temperature of 80°F (27°C). There is also a display which can show battery voltage, PV current in, or current to the battery.

This charge controller and current booster is an ideal match for PV systems. During times of lowest temperature (like in winter when the sun shines least) and lowest battery voltage, the current is boosted the most. This is when it is most needed in PV systems. If you need a charge controller for a PV array of 20 amps

Boost vs Ambient Temperature

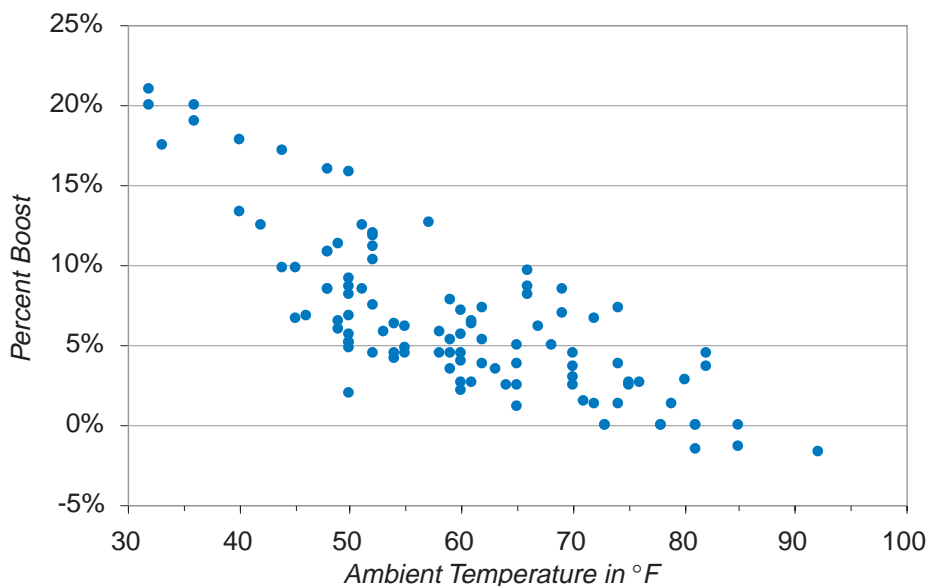

or less, the Solar Boost 2000 is a good choice. The price for this controller is US\$225. We are looking forward to testing Solar Boost 2000's big brother, the Solar Boost 50.

Access

Reviewer: Sam Coleman, Home Power, PO Box 520, Ashland, OR 97520 • sam.coleman@homepower.com

Joe Schwartz, Home Power, PO Box 520, Ashland, OR 97520 • 530-475-3179 • Fax: 530-475-0836
joe.schwartz@homepower.com • www.homepower.com

RV Power Products, 1058 Monterey Vista Way, Encinitas, CA 92024 • 800-493-7877 or 760-944-8882
Fax: 760-944-8882 • info@rvpowerproducts.com
www.rvpowerproducts.com

Photons In, Photons Out
Solar Rechargeable Lamp



- Quality Antique Brass
- Bright White LEDs
- NiMH Batteries
- 90 Day Warranty

See web page
for details:
www.photonlamp.com

Backwards to the Future, Ltd.
PO Box 409, Fennville, MI 49408
Fax: 616-236-6186
email: sales@photonlamp.com

Chinese Diesel Generator-Set

Water Cooled • Electric Start

- Turn Key Complete
- Industrial Quality
- Free Tool & Overhaul Kit
- 3 Full Hours on One Gallon of Fuel
- **230 / 115 Volt, 60 Hz**, Single Phase
- Guaranteed Parts Availability
- Prompt Delivery / Shipping
- Runs Home, Small Farm, Shops
- One Year Limited Warranty

15, 20, 24, 30, 40 & 50 Kilowatt
Diesel Generators are available upon request

*Call Now to Place Your Order,
or For More Information*

Newinli International, Inc.

13445 Yorba Ave., Chino, CA 91710

Phone: (909) 364-0667 Fax: (909) 364-0856

Distributors Wanted

7.5KW
\$2,795



10KW
\$3,162



15KW
\$4,885



The Southern Star in Solar

SERVING THE SOUTHERN UNITED STATES & CARRIBEAN



SOLAR CONTRACTING SINCE 1977

4,000 REFERENCES AVAILABLE

FULL SERVICE DESIGN & INSTALLATION

SITE SURVEYS / LOAD ANALYSIS / ON-SITE TECHNICAL SUPERVISION

**Energy
Conservation
Services**



Tropical Solar Experts

(352) 377-8866



**Siemens Solar
PowerPro™**



Tom & Shirley Lane...ECS Owners

6120 SW 13th Street • Gainesville, Florida 32608 • USA • www.ecs-solar.com

BACKWOODS SOLAR ELECTRIC SYSTEMS

For an Earth Restored and a World at Peace

Independent Electric Power Systems for the Remote Home — Solar Electric, Wind, Hydro

We are a family business, living with our products for over 20 years, and offer the knowledge to help you set up your energy system. Free Consultation. Questions are personally answered.

Our catalog includes a planning guide to help you understand how to put your energy system together—its applications and sizing. We offer lower than usual prices on **Solarex** and **Siemens** PV modules and **Kohler** generators. Our **Trace** inverters include free battery cables. We carry **Sun Frost**, **Nova Kool**, and **ConServ** refrigerators, specialized appliances and lighting, and a range of meters and controls: **Heliotrope**, **SCI**, **Pulse**, and **TriMetric**.

Our \$3 Catalog/planning guide is FREE to *Home Power* readers.



Most items in stock for immediate shipment. We accept VISA, MasterCard, American Express, and Discover



Steve & Elizabeth Willey • 1395-HP Rolling Thunder Ridge • Sandpoint, Idaho 83864

Phone: (208) 263-4290 • Fax: (208) 265-4788 • E-mail: info@backwoodssolar.com • Web: www.backwoodssolar.com

**Toronto
Surplus
& Scientific Inc.**

STORE: (416) 490-8865 FAX: (905) 887-0006 OFFICE: (905) 887-0007

608 Gordon Baker Rd. Willowdale, Ontario, Canada Zip: M2H-3B4



NOVA ELECTRIC CORP GALAXY 2KW INVERTER

These inverters are brand new, unused in the original carton. Input voltage is 22-34Vdc 140A max, output voltage is 120Vac @ 20.8A 60 Hz. These are high efficiency sine wave inverters, with full alarm outputs and phase sync in/output. Operator's manual is included with each unit.
Price: new unused.....\$925.00ea



TEKTRONIX 465B OSCILLOSCOPE

Superior Quality, only found in Tek products, is built-in to this 100 MHz dual trace scope. It features delayed timebase, Ch1/Ch2 sum or difference, Vertical deflection range 5mV-5V/div. This is an excellent general purpose oscilloscope
Very good condition.....\$750.00
Tek 465 good condition.....\$650.00
Tek 465M ruggedized military ver \$495.00
New "Avex" 100MHz scope probes \$24.00
465(?) Manual included with purchase.....



MILITARY STANDARD 24V DC GENERATOR

Superior QUALITY plus rugged design are features of this deluxe 2 cylinder 4 stroke gasoline generator. It features meters for voltage & current indication, main circuit breaker and voltage adjustment. Shielded wires and plugs comprise the RFI suppressed ignition system eliminating all radio noise. These units are "new" in the original carton complete with operator's manual and pull-start cord. Output voltage is adjustable approx 18-32vdc (24.28v) nominal @ 53.3A (1.5Kw) continuous duty 100% load.
Price: \$579.00 ea. or 2 units for \$1100.00

ALL PRICES IN U.S.\$

Please include telephone/fax with mail-in orders. Orders must be prepaid by guaranteed instrument. Please call if you have any questions.

View our web inventory list and give us a call!

STORE: (416) 490-8865

www.torontosurplus.com

SHIPPING IS NOT INCLUDED IN THESE PRICES. PLEASE CALL FOR RATES.

SOL WEST

Renewable Energy Fair



Jennifer and the Bear test the completed Voltsrabbit.

On July 24 and 25, over 1,500 renewable energy enthusiasts gathered in John Day, Oregon for the first annual SolWest RE Fair. Did we ever have a good time!

I met and talked with folks from a variety of western states, Canada, and Mexico. Folks came from over 2,000 miles (3,200 km) away just to attend this fair. Perhaps the most amazing journey to SolWest was by The Sol Brothers—Bob Maynard,

Gene Hitney, and Larry Elliot—who drove a solar-powered truck over 290 miles (465 km) to reach John Day.

Folks Came from Far and Wide to Where?

John Day is a tiny town in eastern Oregon. With a population of about 1,800, it's hard to even find it on the map. I know most of the SolWest attendees had never been to John Day before. On our drive there, I wondered how this small town would react to having its population nearly doubled by RE maniacs. I need not have worried—the local folks were very hospitable and even attended the fair!

Primarily a cattle and timber town, John Day is looking to diversify its industries. SolWest was thoroughly supported by the local financial and political infrastructure. These folks are smart. They realize that with over 300 full sun days yearly, John Day is a great site for solar energy and new solar industries.

The Friday night before the SolWest fair, there was a networking dinner for the exhibitors. At this dinner, local folks spoke to the assembled group of over 150 people, who were busy stuffing their faces with a great meal. The local businesspeople and politicians are ready to bring solar energy industries into John Day.

Parabolic barbeque.



Harnessing youth power.



Learning new tricks.





Water pumping has many uses.



RE information exchange under the Oregon sun.

They have the energy, the work force, and the spark to do it, too.

John Day is located in the middle of Oregon's high mountain desert country. The scenery is spectacular and varied—everything from big mountains to rivers and forests. And while John Day may appear to be in the middle of nowhere Oregon, it's really about the same distance from a number of large metro areas. Folks traveling from Boise, Reno, Salt Lake City, San Francisco, Portland, Seattle, Spokane, and Missoula can all reach John Day in a day's drive.

What a Fair!

SolWest was held on the Grant County Fairgrounds, which is well suited to an event of this size. There was plenty of room for over fifty booths displaying all kinds of RE technology, and the twenty-nine

workshops during the weekend. There was ample space for folks camping out or spending the weekend in their RVs.

The booths ran the gamut from very official and corporate to down-home funky. At SolWest, Idaho Power rubbed shoulders with Mom & Pop Solar, and there wasn't a single fist fight. One RE company—I can't say who—even hooked up a couple of PVs to a Micro Sine inverter and created an instant guerrilla system. They plugged it into the grid right under the eyes of the local utilities, and everyone smiled. Now that's what I call an energy fair activity!

Not all booths were directly concerned with energy. Some focused on building, conservation, gardening, and of course, food. I tasted some of the best BBQ ever at one of those booths.

The folks attending SolWest had an interesting and diverse mixture of ages and backgrounds. They all had one thing in common—an intense interest in renewable energy. Many of the folks already had systems up and running or were planning on installing an RE system soon. The *Home Power* booth was jammed with folks asking technical questions. We always create a mini living room at our booth so folks can sit and talk. At SolWest, this area was filled with people sharing information about what was working and what wasn't.

Workshops

There were twenty-nine workshops held over the weekend on all phases of RE and sustainable living. If you weren't at SolWest, you missed hearing a long list of RE pioneers presenting the information that they know best. The workshop

Old stuff: Low tech wind power.



New stuff: High tech hot water.





Jennifer Barker did it!



Another Guerrilla Solar happening.



Mike and Shari convert it on the spot.

presenters included Michael Hackleman, Kelly Larson, Steve Willey, Doug Boleyn, Bob-O Schultze, Don Harris, Frank Vignola, Mike Oehler, Candice Gossen, Dale Costich, and many others.

Mike Brown and Shari Prange had the very best workshop—they converted a VW Rabbit into an electric Voltsrabbit over the weekend and had it driving around the fairgrounds by Sunday afternoon! See Shari's report on the conversion in this issue.

It wasn't just information that circulated during this fair. I watched

many folks hauling PV modules, solar cookers, inverters, instruments, and wind generators out to their cars. Many of the vendors with "Fair Specials" went home with empty trucks and fat wallets. If there is anything better than having your questions answered by the experts, it has to be taking home boxes of PV modules at great prices!

Jennifer Barker

Energy fairs such as SolWest don't just happen. Generally, one or two core organizers are the driving force. The sparkplug for SolWest was Jennifer Barker. Jennifer began her work well over a year ago. She

began with a firm foundation by creating the nonprofit organization, The Eastern Oregon Renewable Energy Association (EORenew), to sponsor the fair. She worked tirelessly and meticulously to ensure that every detail of this fair was the best it could be. It showed. If anyone wants to know how to do this job right, call Jennifer.

Next Year?

We have big plans for next year's SolWest. The SolWest folks and *Home Power* are teaming up to present a pre-fair workshop, where we will design and install a working PV system. This system will be

The Sol Brothers got there on pure photons.



Active, passive, and photovoltaic—SolWest had it all.





Dealers did what dealers do.



Solar gets around!

permanently intertied to the local grid on the Grant County Fairgrounds. I will be teaching the classroom sessions and Joe Schwartz will be teaching the wrenching sessions. If you want to attend this workshop, or if you want to see your company's RE gear become part of this workshop and on permanent display at the Grant County Fairgrounds, contact Jennifer Barker.

Homeward into the Setting Sun

It was a wonderful weekend. If you weren't there, then you don't know what you missed. The whole *Home Power* crew arrived back home pooped. We had too much fun. We talked shop with way too many folks. We can't wait to do it again.

Access

Author: Richard Perez, *Home Power*, PO Box 520, Ashland, OR 97520

530-475-3179 • Fax: 530-475-0836
 richard.perez@homepower.com
 www.homepower.com

SolWest: Jennifer Barker, The Eastern Oregon Renewable Energy Association, PO Box 485, Canyon City, OR 97820 • 541-542-2525
 solwest@eoni.com
 www.eoni.com/~solwest



SUNRISE • SLOWPUMP • FLOWLIGHT BOOSTER PUMP • SOLARFORCE • SOLARAM • SOLAR CENTRIFUGAL

+
=

(FILL IN THE BLANK)

A:

Running an inefficient water pump is like throwing money down the drain. Dankoff pumps reduce your power consumption, saving you money from the day you buy your system. Ask your dealer for details or call us toll free at 888-396-6611. You can also visit us on the Web at www.dankoffsolar.com or e-mail us at pumps@dankoffsolar.com.

The answer's so simple. Get a Dankoff pump.

SUNRISE • SLOWPUMP • FLOWLIGHT BOOSTER PUMP • SOLARFORCE • SOLARAM • SOLAR CENTRIFUGAL

SOLAR PANELS

CANROM-7(7Wp)	\$ 78.00
CANROM-20	\$ 132.00
CANROM-40	\$ 268.00
CANROM-50	\$ 329.00

CANROM-65 . . . \$343.00

CANROM-75	\$ 460.00
CANROM-S1*	\$ 706.00
CANROM-S2**	\$ 1,199.00

* **Canrom-S1** is a kit containing two Canrom-40 panels, an 8 Amp voltage regulator, aluminum mount with three inclination positions, 60 feet of gauge 10 cable, fuse box on the panel side of battery, and complete installation instructions.

** **Canrom-S2** contain four Canrom-40 panels, a 12 Amp voltage regulator, aluminum mount with three inclination positions, 60 feet of gauge 10 cable, fuse box on the panel side of battery, and complete installation instructions.

CANROM Photovoltaics, Inc.
 Call or fax for a free catalog: 716-282-2975
 or email using : www.canrom.com



Specializing in **COMPLETE** systems design

*Solar Electric, Heating, Water, & Appliances
 Including complete CAD design services*

We can supply everything you need to be off-grid... inverters to modules to batteries, including your kitchen stove.

All the best brands...

TRACE • KYOCERA
APT • BUDERUS
THERMOMAX
WATTSUN
SOLARJACK • IBE
PEERLESS-PREMIER



Authorized
GOLDEN GENESIS
 Dealer

Free Catalog to Home Power Readers in USA



P.O. Box 340, 262 Badger Road
 Ennis, MT 59729



Ph 406-682-5646 • Fx 406-682-5644

REMOTE?

Dealerships Available



- Full Compliant
- Full Assembly
- No Wiring
- Complete
- Portable

GenSun, Inc. 10760 Kendall Road, Lucerne Valley, CA 92356 - (760) 248-2689 - solar@gensun.com

LEADERSHIP IN ALTERNATIVE ENERGY

GENSUN

INTEGRATED SOLAR ELECTRIC SYSTEMS

Intermountain Solar Technologies, Inc.



Inverters

DR 1512	\$ 739
DR 2412	\$ 999
DR 3624	\$ 1139
SW 2512	\$ 1849
SW 4024	\$ 2389

Regulators

C40	\$ 149
PM 60	\$ 229

Solar Panels

V L X 53	\$ 259
SR 50	\$ 269
MSX 64	\$ 314
BP 275	\$ 375
MSX 83	\$ 409
BP 90	\$ 479
SR 100	\$ 490
AP 120	\$ 559

Wind Generators

Air 403	\$ 519
---------	--------

Shop On Line - www.intermountainsolar.com

Or Write - 10288 S. Jordan Gateway #D - S. Jordan, UT 84095

Specializing in Affordable Power - Call Today (800) 671-0169

You Can't Always Rely on the Grid

But you can always rely on Rolls batteries.



You have invested in an alternative energy generating system. Make sure your battery is not your weakest link. Insist on North America's best deep-cycle battery... Rolls.

- Dual-container construction eliminates potential leaks, stray current, and decreases maintenance
- Unsurpassed cycling due to the most dense active material in the industry
- Modular construction for easier installation
- Average life expectancy is 15 years - Warranted for 10 years

Rolls

BATTERY ENGINEERING

1-800-681-9914

Surrette Battery Company Ltd., Springhill, NS, Canada, B0M 1X0
www.surrette.com e-mail: jds@surrette.com

Renewable Energy on CD-ROM

**Windows,
Mac, or
Unix**

Contains the original magazine layouts
(text & graphics)

**In Adobe Acrobat PDF® format: Color • Fully Indexed
Searchable • Exportable • Printable**

Acrobat Readers included

Solar4

**HP61 - HP70
(Oct. '97 - May, '99)
over 1200 pages of Home Power**

*Plus: audio RE lectures,
RE system analysis software,
& RE business database*

Solar3

**HP43 - HP60
(Oct. '94 - Sept. '97)
over 2000 pages of Home Power**

Solar2

**HP1 - HP42
(Nov. '87 - Sept. '94)
over 3900 pages of Home Power**

**Home Power
PO Box 520**

Ashland, OR 97520

Phone: 541-512-0201

Web: www.homepower.com

\$29^{ea}

Postage Paid

(International orders add \$3)

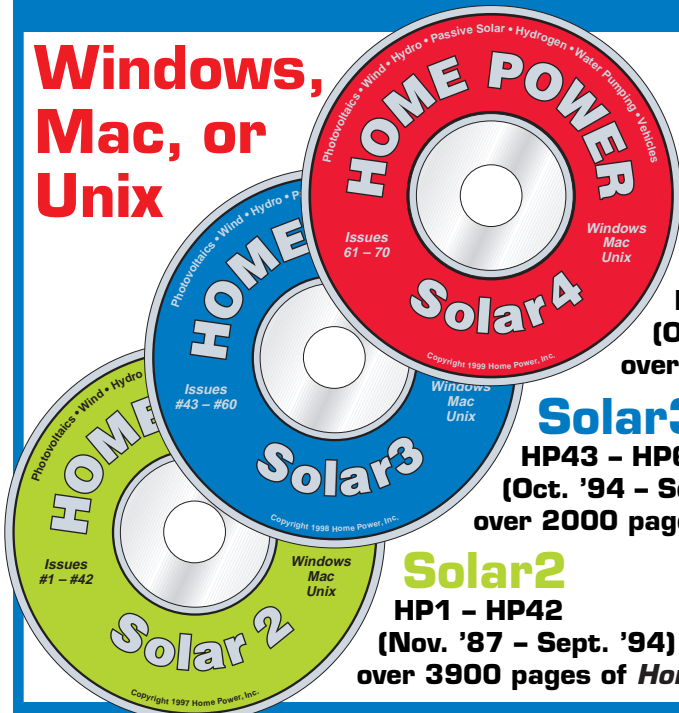

For credit card orders call Home Power at 800-707-6585

Renewable Energy & Sustainable Living Workshops

At the ReNew the Earth Institute

MREA's new educational facility in the rolling farmland of Central Wisconsin

**Green
Building
Technology**

- Basic / Intermediate PhotovoltaicsOctober 2-3
- Solar Hot WaterOctober 9
- Active Solar Space HeatingOctober 10
- Masonry StovesOctober 16



Photovoltaics, Wind, Hydro

*Watch this space
for more upcoming workshops
throughout the year!*



Solar
Hot Water

Call or write for more information and course descriptions.

Midwest Renewable Energy Association, 7558 Deer Rd., Custer, WI 54423

phone (715) 592-6595 • fax (715) 592-6596 • mreainfo@wi-net.com • www.the-mrea.org



Home Power's Business



"The man who on his trade relies
Must either bust or advertise."

Sir Thomas Lipton — 1870

Display Advertising

Advertising Rates per Consecutive Insertion

	Single Insertion	Three Insertions	Six Insertions	Ad Area sq. in.
Full Page	\$1,500	\$1,350	\$1,275	64.1
Half Page	\$840	\$756	\$714	32.1
Third Page	\$600	\$540	\$510	21.4
Quarter Page	\$471	\$424	\$401	16.0
Sixth Page	\$334	\$300	\$284	10.7
Eighth Page	\$268	\$241	\$227	8.0
Twelfth Page	\$188	\$169	\$159	5.3

Four process color (CMYK) in any sized advertisement is a flat rate of \$185 per insertion. For inserts, and current subscriber/circulation demographics, please call us.

Home Power is published bi-monthly. The ad deadline for the Dec 99 / Jan 00 issue (HP74) is 14 Oct 1999. Call 530-475-3179 for further details.

MicroAds

MicroAd rates are 10¢ per character. Characters include letters, numbers, spaces, and punctuation marks. \$15 minimum per MicroAd insertion. Send a check with your ad. We do not bill MicroAds.

Home Power magazine for Resale

Quantities of *Home Power* magazine are available for resale by distributors, newsstands, bookstores, energy businesses, and others. Please call, email, or write for rates and shipment specifics.

First Class Home Power Subscription

Get 6 issues of *Home Power* magazine via First Class U.S. Domestic Mail for \$36. Many of you have asked for faster delivery, so here it is: First Class *Home Power*. All First Class issues shipped in an envelope. We start your subscription immediately with the current issue.

International Home Power Subscriptions

Due to the high cost of international mailing, we charge more for *Home Power* international subscriptions.

1 YEAR (6 issues) INTERNATIONAL RATES:

All payments in U.S. currency ONLY!

Canada:	Air — \$36	Surface — \$30
Mexico:	Air — \$38	Surface — \$30
Western Hemisphere:	Air — \$40	Surface — \$30
Europe:	Air — \$53	Surface — \$30
Asia and Africa:	Air — \$64	Surface — \$30
Pacific Rim:	Air — \$64	Surface — \$30

Surface shipment may take up to three months. All international issues are shipped in mailing envelopes. International subs are best paid for by either VISA, MasterCard, or funds from a U.S. bank.

International orders: Call: 541-512-0201
Fax: 541-512-0343

Back Issues of Home Power magazine

Back issues through #20 are \$3.25 each (\$4.25 each outside USA) while they last. Sorry, no more issues #1–12, 14, 15, 16, 25, 35, 36, 38, 40, 41, 59–61, 63–65, & 67. Back issues of #21–45 are \$4.75 each (\$6 each outside USA). Back issues #46–current are \$5.75 each (\$7.25 outside USA). Back issues are shipped First Class mail. See the ad index for current *Home Power* back issue specials. Issues #1–42, 43–60, & 61–70 on CD-ROM for \$29 each (US\$32 outside USA) Win/Mac/Unix.

Second Class Home Power Subscription

Get 6 issues of *Home Power* via Second Class U.S. Domestic Mail for \$22.50. Second Class can be forwarded for one issue (2 months), so let us know immediately if you move! We start your sub with the next scheduled issue, so please allow ten weeks for your first copy to arrive.

ACCESS ➡ **Home Power, PO Box 520, Ashland, OR 97520 USA**

800-707-6585 or 541-512-0201 Subscriptions and Back Issues

530-475-3179 Advertising and Editorial • www.homepower.com



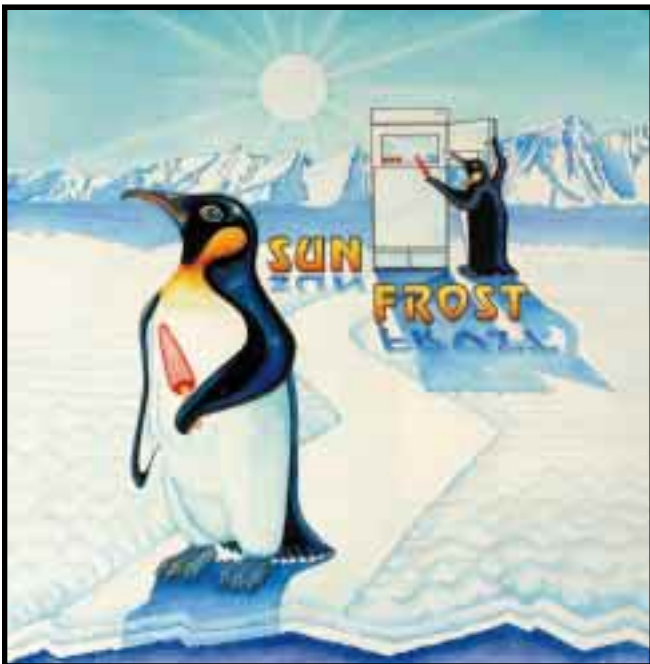

**Not enough sunshine in your life?
Slash the cost of your power system with**

SUN FROST

P.O. Box 1101, Arcata, CA 95518-1101
Phone: 707-822-9095 • Fax: 707-822-6213 • www.sunfrost.com

Experience the Simple Elegance of Canyon Turbines



We do turnkey systems for homes or resorts
& grid-intertie for net metering in the Rocky Mountain Region.



- Consulting
- Design
- Site Review
- Installation
- Service

Solar Plexus, 130 W. Front St., Missoula, MT (406) 721-1130

With 25 years of experience, J. Bornay offers you a complete line of windturbines, from 60 W to 12 Kw.

Juan y David Bornay, S.R.C.
P.O. BOX 116 • E-03420 CASTALLA (ALICANTE) SPAIN
TEL +34 965 560 025 • FAX +34 965 560 752
WEBSITE: www.bornay.com
e-mail: bornay@bornay.com

RENEWABLE ENERGY with the EXPERTS

*An Instructional Video Series
on the Basics of Residential Renewable Energy*

Residential Solar Electricity **\$39.95**
with Johnny Weiss, 48 min. *each*

Johnny Weiss is one of the founders and teachers at Solar Energy International, in Carbondale, CO.

Residential Wind Power
with Mick Sagrillo, 63 min.

Mick Sagrillo has installed and repaired over 1,000 wind turbines.

Residential Microhydro Power
with Don Harris, 44 min. Don Harris has designed and manufactured over 1,000 microhydro power plants.

Batteries with Richard Perez, Editor in Chief and founder of *Home Power* magazine.

Solar Water Pumping with Windy Dankoff, 59 min. Windy Dankoff has been designing and installing solar-powered water pumping systems for 15 years.

Add \$5.00 shipping for international orders

Home Power, Inc., PO Box 275, Ashland, OR 97520
toll free in USA: 800-707-6585 • 541-512-0201

Fax: 541-512-0343

Web: www.homepower.com



Reviewed in HP56

BOOST YOUR SOLAR OUTPUT

Maximum Power Point Tracking Technology Can Boost Your Solar Output 30% Or More!



- Patent Pending MPPT Technology extracts more power from your PV array.
- Advanced high efficiency power conversion technology delivers up to 30% more charge current to your batteries
- Superior PWM voltage control and available temperature compensation
- User friendly display monitors PV charge performance
- Solar Boost™ 2000 (20 amp 12V)
- **NEW Solar Boost™ 50 with multistage charging (50 amp 12V/24V)**

Our products are manufactured in the USA for the highest level of quality and reliability. Other products available include multistage AC chargers, inverters, solar panels and more.

Contact RV Power Products or a dealer near you. New distributors welcome.

RV POWER PRODUCTS
1058 MONTEREY VISTA WY
ENCINITAS, CA 92024

(800) 493-7877
(760) 944-8882

Discover e-mail: info@rvpowerproducts.com/www.rvpowerproducts.com

1-888-MR SOLAR

America's Solar Super Store

Nobody's Cheaper!

SOLAREX®
From only \$5 a watt



TRACE SW 4024
\$2399

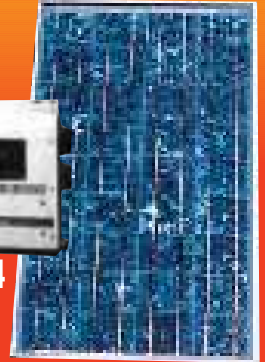

VLX 53 \$265



Top solar technology at rock bottom prices.

free catalog

Toll free 1-888-677-6527 www.888mrsolar.com



The Book on Solar Cookers

Back by Popular Demand

A second edition, fully updated and revised.

Includes:

- A history as well as a who's who in the solar-cooking movement
- Guidelines for designing your own cooker
- Plans for building the **SunStar** cooker with salvaged and inexpensive materials
- Tips and tricks for cooking with the sun

With 200 Photographs & Diagrams

\$15

Outside USA add \$5 for air shipping

Call Home Power Publishing
800-707-6585

Outside USA 541-512-0201



T-SHIRTS

Guerrilla Solar

Install by Night—Power by Day

On Black: \$15, or Camo: \$18
International orders add \$5 for air shipping

Call, see our web site, or send check or money order
800-707-6585 (541-512-0201 Outside USA)
www.homepower.com

Home Power, PO Box 520, Ashland, OR 97520

TOP SECRET

GUERRILLA SOLAR: the unauthorized placement of renewable energy on a utility grid.

PROFILE: 0006

DATE: September, 1999

LOCATION: Somewhere in the USA

INSTALLER NAME: Classified

OWNER NAME: Classified

INTERTIED UTILITY: Classified

SYSTEM SIZE: 800 watts of PV, 100 watt wind generator

PERCENT OF ANNUAL LOAD: 10%

TIME IN SERVICE: 3 years

Net Metering? No Problem! Although the thought of putting one over on the local utility has some appeal, the decision to run my renewable energy system in grid intertie mode was made because I needed more precise charge control of the PV array.

For many years, I controlled the state of charge in my battery bank by dumping the excess solar power into an RV-type absorption refrigerator. With the addition of eight Siemens SP75 modules to my array, the job of keeping a handle on battery state of charge became much more complicated. It made good sense to spin the electric meter the right direction--counting down--to consume the excess power produced!

I have a 100 watt Wincharger wind generator and 800 watts of PV. Currently, the PV array consists of eight Carrizo quadlam PVs connected for 12 volt, 200 watt output. These modules are connected directly to the battery bank through overcurrent protection devices and shunts for metering. A Siemens M75 48 watt panel is installed in the system via a series/parallel contactor to allow parallel connection to the quadlams for additional current at 12 volts, or in series to produce 24 volts to run the circulating pump on my solar-heated hot tub.

The eight Siemens SP75 panels are wired in series for 130 volts at 4 amps. The high voltage is wired back to the house through switchgear that allows me to connect the output directly to my electric vehicle for battery charging. When the system is not being used to charge the EV, a 75 amp Todd Power Source charger steps the 130 volts down to 12 volts. This charges the battery bank and drives the Trace SW 2512 inverter in intertie mode. Of course, some losses are inherent in the voltage/current conversion, but given the several options for EV/inverter usage, the efficiency seems to be acceptable.

All of the PVs are mounted on a fixed rack, which is adjusted seasonally. The average output of the array from April to September is about 3.5 KWH per day. This may seem low, but my site is on the west side of a hill. It receives little solar radiation until nearly 10 AM, and surrounding trees begin shading the array at about 6 PM.

Permits? We don't need no stinking permits! Why not go legitimate? Well, every contact that I have ever had with our city's building department has been demoralizing, disheartening, and unproductive, regardless of the subject. Although my system is basically wired to code, I saw a long and difficult path to tread if I attempted to convince the inspectors and the utility of the merits of my interconnection with the grid.

To be fair, the local utility has stated that they will willingly talk to any independent power producers who wish to install an intertied system on a case-by-case basis. But for my little peanut whistle of a power plant, I saw no reason to poke the hornet's nest.

Getting caught? I'm not too worried. The system is safe and the Trace SW series inverters are foolproof. My utility should be worried about Y2K backup generators backfeeding the grid, not the few KWH they won't be selling me this year. Until they come knocking at the door, I guess you could call me a Solar Guerrilla!



Y2K COOKING!

While your computer's on ice and the utility is down you can NOW cook with the...

GLOBAL SUN OVEN

The Ultimate Cooking Appliance!

- Cooks any kind of food with the power of the sun—NO Fuel Needed!
- Reaches temperatures of 360 to 400 degrees Fahrenheit!
- Totally safe—No danger of fire!
- Used daily in 126 countries around the world!
- Ruggedly built for years of trouble-free use!
- As portable as a small suitcase!



\$219

includes FREE UPS delivery within the continental U.S!

To Order Call: 1-800-338-1781

Sunlight Energy Corporation
4411 W. Echo Lane, Glendale, AZ 85302

Ask us about our complete solar electric Y2K back-up systems featuring the NEW DEEP CYCLE dry cell lead acid batteries.

Solar Village Institute Inc.

Renewable Energy Dealer, Installers, Educators
Solar, Wind & Micro Hydro Systems
Serving the Carolinas and Virginia.
Off grid since 1992

Solar Village Institute inc.
Chris and Lyn Carter
PO Box 14, Saxapahaw, North Carolina, 27340
fax/phone (336) 376-9530, voice (336) 376-9292
Email solarvil@netpath.net www.solarvillage.com

Real People, Real Power, Real Goods

For over 20 years, Real Goods has helped people achieve their dream of creating their own sustainable power system

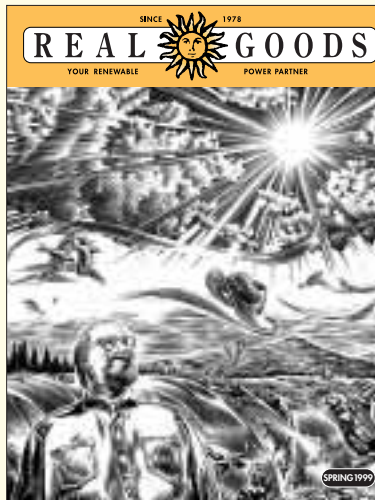

200 Clara Ave., Ukiah, CA 95482

Our knowledgeable technicians will help you make informed decisions about sustainable technologies.

- COMPLETE SYSTEM DESIGN
- BACK-UP POWER SYSTEMS
- SOLAR, WIND, HYDRO



For a free catalog or system design, call 800.919.2400.

Mention code HP91 or visit our website.

www.realgoods.com/renew

Email: techs@realgoods.com



Discover the Power of Solar Energy

**Saturday,
October 16, 1999**

The National Tour of Solar Homes is an opportunity to see how solar energy is working today. Since 1993, thousands of people have visited solar homes in their communities. They have felt the warmth of a sunroom, washed their hands in solar heated water, and watched the meter run backward on a PV-powered home.

**Discover the practical
benefits of solar energy
on the National Tour
of Solar Homes.**

**Sponsored by the
US Department of Energy,
BP Solarex, AstroPower,
Interstate Renewable Energy Council,
and Home Power magazine.**

For information or to find a tour near you, contact:
American Solar Energy Society
2400 Central Avenue, G-1
Boulder, CO 80301
Phone: 303/443-3130
Email: ases@ases.org
Website: www.ases.org





SIEMENS

SUN
FROST



No Power? No Problem!

Solar • Microhydro • Wind Power • Water Pumping • Remote Communications

We do it all and we do it right!

There is more to a working renewable energy system than a cheap deal on a pile of hardware. While other companies may seem to be cheaper, none are better at building the right, and most cost-effective, RE system for you.

Electron Connection offers: load analysis, site survey, system design, sales, installation, user training, and tech support long after the warranties expire. We live on renewable energy, have over 17 years of experience, and have established over 300 systems. We specialize in NEC® compliant, safe systems that will make your Electrical Inspector smile!

Complete service including installation: We have done systems from Ketchikan, Alaska to Baja California. We have a network of qualified, competent Electron Connection associates across the country. If you need installation or design assistance we will refer you to one in your area. We do it all and do it right the first time!

Equipment via mail order: We offer reasonable deals and technical reality checks. Why settle for a packaged system when you can have yours custom designed by the experts?

Dealers / Installers: Why talk to a “technician” when you can talk to an electrician? We spend half our time in the field installing the equipment we sell you. We KNOW how the systems work and offer technical support, system design assistance, prompt shipment, fair pricing, and NO BULL. Local Referrals. Electrical competence is required. Write today for your dealer application.

Electron Connection

PO Box 203,
Hornbrook, CA 96044 USA
Voice • Fax: 530-475-3401
E-mail:
econnect@snowcrest.net
Web Page:
www.electronconnection.com
CA Electrical Lic #613554



- **Photovoltaics** — Siemens - BP - Solarex
- **High-Quality Batteries** — Trojan - GNB
- **Power Inverters** — Trace - Exeltech
- **Instrumentation** — Cruising - Fluke - Wavetek
- **Charge Controls** — Heliotrope - Trace
- **Trackers & PV Mounts** — WattSun - Zomeworks - Direct Power
- **Microhydro Electric Powerplants** — ES&D - Harris Hydro - Lil Otto Hydroworks!
- **Wind Generators** — World Power Tech - Southwest Windpower
- **Pumps** — Dankoff Solar - Solarjack - SHURflo
- **Water Heaters** — Myson - Aquastar
- **Efficient Lighting** — Phillips - Osram - S&H
- **Safety Gear** — APT - Heinemann - Cutler & Hammer - Square D Products
- **Radiotelephones**



1-800-945-7587

LED there be Light!

Jonathan Scherch

©1999 Jonathan Scherch

Old projects (amorphous panels that needed assembly) now provide power for new projects—homebrew LED lighting.

Here on the shores of Puget Sound, we do get our fair share of sun, wind, and water. When it doesn't rain, we are able to harvest the sun for electricity.

DIY PV System

A few years ago, I organized a cooperative bulk order of PVs with friends and fellow ham radio operators. We purchased 75 unwired, unframed 15 watt amorphous solar panels for about \$25 each. My share was ten panels. As each of us assembled and finished our panels, we learned how to handle these delicate units, which are made of fragile, untempered glass. I wired and framed my panels using silver braided bus wire, conductive epoxy, and pressure-treated wood. Later, I sealed the edges and backs with weatherproof caulk and urethane sealant. They have been going strong for three years now.

With panels in place, I purchased a Trace C-12 controller and a Schottky diode (to prevent battery drain after dark). The system charges two Trojan T-105 golf cart batteries equipped with those "things that work"—Hydrocaps. Our system provides more than enough electricity to power my multi-mode ham radio station (KK7PW). With power to spare, I recently decided to tackle a little "homebrew" project, inspired by the *LED Lighting Shootout* in *HP60*.

In Love with LEDs

I chose to go with LEDs (light emitting diodes) because of their touted long life (100,000 hours!), durability, and the fun and ease of homebrewing with them. We use these lights primarily as overhead reading lamps, though by raising them toward the ceiling, they provide adequate, soft light for our living room. With some decorative chain and lampshades, the lights add to the existing decor.

I've programmed the automatic lighting function of the C-12 so that the lights come on at dark, when our solar panel output drops below 3.5 volts for at least 60

Snug as a batt in a tub.

[Editor's note: battery acid can turn styrofoam into unmanageable goo!]



seconds. The controller is set so that the lights shine for about four hours. We never worry about who will turn out the lights! What's more, the dusk-to-dawn function provides security lighting in our home when we are away.

In the future, we might experiment with intensive lighting for our early spring seedlings and indoor houseplants. Our Northwest winters leave our plants (and us) hungry for light! We might even take the LED lights camping, given their light weight, waterproof construction, and ultra low power appetite (less than 500 milliamps).

Brewing

Having more experience homebrewing beer than electronics, I needed advice on how to apply what I had learned in the *Shootout* article. I contacted Hosfelt Electronics to request their catalogue, and then made a call to *HP* headquarters and spoke to Richard Perez.

My guess is that he could sense the novice nature of my call and offered patient, sage advice on how to go about building the project I had in mind (Thanks, Richard!). In a few weeks, I had acquired all the parts I needed to build our lights, along with a new soldering iron and accessories.

I opted to purchase 26 white, full-spectrum LEDs with wide-angle beams (2,000 millicandles) to make two lamps, using 12 and 14 LEDs respectively. At US\$3.99 each, the LEDs, along with the other components, made the initial cost of the project quite noticeable. But the lights could last some 60 years on pure sun juice, so I felt that their long-term economic and environmental benefits were justifiably impressive. I could save money, use less Northwest hydro-electric power (save the salmon!), and increase our level of self reliance.

One of Jonathan's lights and its shade.



Jonathan Scherch enjoying his favorite mag illuminated with the fruits of his labors.

The planning, assembling, and soldering of the lights took me about eight hours. I wired two LEDs with one 220 ohm resistor in series, and then connected each assembly in parallel. Richard explained that the resistor is there to limit the maximum current through the LED semiconductor junction. LEDs don't much care about forward bias voltage. What counts is current through the junction—max is usually around 25 to 30 milliamperes.

After soldering the components in place, I coated the back side of the lights with Liquid Electrical Tape, a brush-on electrical sealer. I may elect to use a more heavy-duty sealant in the future, but this is what I had

LED Light Parts List

Item	Part Number	Quan.	Cost (US\$)	Total Cost
LEDs, 5 mm bright white	25-353*	26	\$3.99	\$103.74
Schottky diode, 40 amp, 400 V 3.6-4 VDC 2,000 mcd	DO-203AB**	1	\$4.13	\$4.13
Resistors, 220 Ω 3 packs of 5	271-111***	13	\$0.29	\$3.77
Perforated board 2 3/4 by 3 11/16 inches	276-158***	1	\$2.39	\$2.39
Voltage regulator 12 VDC 1 amp	276-1771a***	1	\$1.49	\$1.49
Soldering iron, 25 watt	64-2070c***	1	\$6.99	\$6.99
			Total	\$122.51

* Hosfelt Electronics

** Radar Electronics

*** Radio Shack

LED Light Schematic

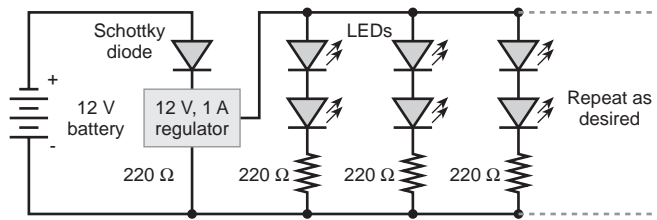

on hand at the time, and so far it seems to work well. The lights are fed by a voltage regulator via our solar electric system fuse box. The regulator is a 12 volt, 1 amp component available off the shelf at Radio Shack.

As this was my first attempt at electronic homebrewing, I enjoyed the opportunity to apply some simple electronic theory in an effort to produce a practical appliance. Whether homebrewing light or lager, I highly recommend the experience.

Access

Jonathan Scherch, Ph.D., KK7PW, Graduate Program on Environment & Community, Antioch University, 2326 Sixth Avenue, Seattle, WA 98121-1814
206-441-5352 ext. 5710 • Fax: 206-441-3307
scherch@antiochsea.edu • www.antiochsea.edu/ec

Hosfelt Electronics, 2700 Sunset Blvd., Steubenville, OH 43952 • 800-264-6464 or 740-264-6464
Fax: 800-524-5414 or 740-264-5414
catalog@hosfelt.com • www.hosfelt.com

Radar Electronics, 168 Western Ave West, Seattle, WA 98119 • 800-723-2773 or 206-282-2511
Fax: 206-282-1598 • done@radarinc.com
www.radarinc.com/pages/radsea.html

Radio Shack, 100 Throckmorton St., Suite 1500, Fort Worth, TX 76102 • 800-843-7422 or 817-415-3011
Fax: 817-415-3240 • support@tandy.com
www.radioshack.com



NO HASSLE WIND POWER
Rugged 18" blade Ampair 100 produces up to 100 Watts *continuously*, 24 Hours per day, at wind speeds from 8 to 100+ mph. No brakes or furling needed...guaranteed at any windspeed! Veteran of 3 years *continuous* Antarctic service. Roof mount is OK; pole mount is better. Put it up, hook it up to the batteries and forget it!

Jack Rabbit Energy Systems
425 Fairfield Ave., Stamford, CT 06902
(203) 961-8133 • FAX (203) 961-0382
e-mail: jackrabbitenergy@worldnet.att.net

NO-HASSLE WATER POWER
If you have a reasonably fast running stream or tide nearby and 12" of water clear, Aquair UW Submersible Generator can produce 60 to 100 Watts *continuously*, up to 2.4 KWH per day. **NO TURBINES, NO DAMS, NO PIPES!** Water speed 5 mph (brisk walk) = 60W. 8 mph (slow jog) = 100W. Timber, rock, or natural venturi increases output.

12 or 24 VDC

SUNWEAVER
Design and Installation of Independent & Back-up power
Serving New England Since 1985

1-800-SUNWEAVER
Route 4 Northwood, NH 03261
Phone: 603-942-5863 ~ Fax: 603-942-7730
Web: www.sunweavers.com ~ e-mail: fonature@tiac.net

BATTERY BOX VENTILATOR & BACK DRAFT DAMPER

- Positive hydrogen venting
- Stops back drafts
- Keeps batteries warmer
- Increases battery capacity
- Minimal power consumption
- Available in 12, 24 or 48 VDC

* Trace SW Inverter or controller required

Power Vent \$79 + \$7 S&H (cont. U.S.)
CO residents add 3%
Specify 12, 24 or 48V (48V vent \$104)

THE POWER VENT

C.C. Solar Technologies
POB 52, Salida, CO 81201
719.530.0718
Or Ask Your Local R.E. Dealer

Solar Energy International



**Call for a
Complete Catalog
of Workshops
in 2000**

Photovoltaics
Wind Power
Microhydro Power
Solar Home Design
*Natural House
Building*
*Straw Bale
Construction*
Solar Cooking
*RE for the
Developing World*
*Successful Solar
Businesses*



Upcoming Workshops

Renewables for the Northwest, WA Oct. 3
PV Design & Install, WA Oct. 4-9
Microhydro Power, WA Oct. 11-15
PV Design Online Nov. 1-Dec. 10

For more information on SEI,
see the following articles in Home Power:

Jane Goes Solar	HP 49, pg 6
PV Lighting in the Colorado Rockies	HP 50, pg 24
A Phoenix is Raised in Colorado	HP 58, pg 6
Solar Baking Under the Sonoran Sun	HP 59, pg 50
Take Your Bedroom Off the Grid	HP 60, pg 16
Mile High Wind Genny	HP 71, pg 24

Hands-On Education • Sustainable Development

voice: (970) 963-8855 • fax: (970) 963-8866

e-mail: sei@solarenergy.org • web: www.solarenergy.org

P.O. Box 715, Carbondale, Colorado, USA 81623

Vermont Solar Engineering

800.286.1252 - fax 802.863.7908

*When Y2K goes away,
we'll still be here.*



We pride ourselves on being a hands-on dealer/installer, selling what we know to work well from down-to-earth experience. We didn't arrive on the scene yesterday, and won't disappear after the sale, either. So if you're looking for support from a company *not* riding the Y2K cash cow into the sunset, please give a call.



The Chargeboost™ Transformer squeezes the maximum current from a modified sine wave inverter's battery charger. If your charger & generator are not performing well together, you'll be impressed with the results. **Starting at \$129**

3 KW Auto-toroid™ Transformer, A high efficiency, UL listed, lightweight 120/240 volt step-up toroidal unit. Includes 20a, dp circuit breaker on output. Factory wound for Vt. Solar. **\$299**



Surrette KS21 2v, 1000 ahr battery

Designed for maximum cycles and infrequent watering. Expected to last 15+ years in service, this battery has a 10 year warranty (3 years unconditional, 7 years pro-rated), and is among the toughest, longest lasting lead acid you'll find anywhere.

12 vdc 1000 ahr string (6 cells) **\$1,259**
24 vdc 1000 ahr string (12 cells) **\$2,496**



...Other Surrette Batteries

CH375-L16
6v, 375 ahr,
5 year warranty.
\$ 189

T12-250
12v, 250 ahr, 7 year warranty.
\$ 239

Trojan T-105
6v, 220 ahr
\$65



Model 2020 Bogart TriMetric meter
a customer favorite –
only **\$169** including shunt
and shipping !!

Servel Propane Fridge

This refrigerator offers spaciousness, a base mounted control panel, and temperature control. Piezo igniter, flame safety valve, and combined electric and gas thermostat. 8.0 cubic feet.

\$1049



Solar Modules

Siemens SP75 75 watt (17v@4.4a) **\$ 399**
Siemens SR100 100 watt (17v@5.9a) **\$ 495**
AstroPower AP1106 110 watt (16.7v@6.6a) **\$ 529**

Protect your Investment !! **Delta Lightning Arrestors**
LA 302 R (ac protection) . . . **\$ 29**
LA 302 DC (dc protection) . . **\$ 39**

← **** SHIPPING EXTRA** except where indicated →

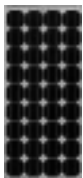

Vermont Solar Engineering
PO Box 697
Burlington, Vt. 05402

Hands-on dealer / designer / installer of the best in renewables since 1991

Call or visit our on-line catalog for excellent Siemens and Trace Pricing

www.vtsolar.com

WE WROTE THE BOOK ON ELECTRIC CAR CONVERSIONS

CONVERT IT How-To Manual

by Michael Brown with Shari Prange

Expanded & Updated 3rd Edition
\$30.00 tax & postage included

www.electroauto.com

"We built Mr. Brown's car,
and we won." Bruce Burk,
St. Johnsbury Academy,
1991 American Tour de Sol
Open Class Winner.



ELECTRO AUTOMOTIVE
POB 1113-HP, FELTON, CA 95018

"First-rate history, excellent writing, great storytelling..."

—Neville Williams, SELCO

FROM SPACE TO EARTH The Story of Solar Electricity John Perlin

From Space to Earth, by the author

of the critically acclaimed *A Forest Journey* and co-author of the solar classic *A Golden Thread*, tracks the evolution of photovoltaics, the direct conversion of the sun's energy into electricity via solar cells.

From shaky 19th-century beginnings, to high-visibility success in the space program, to our increasing—and largely unrecognized—reliance on this subtle, silent energy source, John Perlin tells the true and amazing story of the technology and the truly amazing individuals who brought it to light. Details current advances, and examines applications in both the developed and developing world.

*From space to earth. From Mali to Manhattan.
From the mountains to the oceans. From the utility to your roof.
The history of photovoltaics.*

"An important contribution on the eve of the 'solar century.'"

Available for \$35 postpaid from **aatec publications**

ISBN 0-937948-14-4 240 pages 125+ illus. hardcover July 1999 \$32

To order, or for more information, contact **aatec publications**

800.995.1470 voice or 734.995.1470 • 734.995.1471 fax
aatecpub@mindspring.com

PO Box 7119 Ann Arbor MI 48107

Visa/MasterCard/American Express accepted.



Tumbler Tech's New **PowerPro** DC to AC Power Inverters

PowerPro 125 (125 watts continuous)



Model Number : TP-125
Input Voltage : 10-15 VDC
Output Voltage : 115 VAC
Frequency : 60Hz +/- 3%
Continuous Output : 125W
Surge Power : 200 Watts

PowerPro 200 (200 watts continuous)



Model Number : TP-200
Input Voltage : 10-15 VDC
Output Voltage : 115 VAC
Frequency : 60Hz +/- 3%
Continuous Output : 200W
Surge Power : 400 Watts

PowerPro 300 (300 watts continuous)



Model Number : TP-300
Input Voltage : 10-15 VDC
Output Voltage : 115 VAC
Frequency : 60Hz +/- 3%
Continuous Output : 300W
Surge Power : 400 Watts

PowerPro 500 (500 watts continuous)



Model Number : TP-500
Input Voltage : 10-15 VDC
Output Voltage : 115 VAC
Frequency : 60Hz +/- 3%
Continuous Output : 500W
Surge Power : 800 Watts

Palo Alto HQ: (650) 494-3322 • Fax: 494-3062
e-mail: PowerPro@TrumPower.com
Web Site: www.josephson-ent.com/tumbler

Dealers Wanted



Reliable People ... Reliable Products ... Reliable Power

SunWize Technologies is looking for experienced solar dealers who want to be a member of our team. Our dealer program includes:

- **Technical support**
- **Training seminars**
- **Cooperative advertising**
- **Lead distribution**
- **Large product inventory for same day shipping**
- **Complete catalog and design guide**

We pride ourselves in supporting our dealers with personal attention. Call our Dealer Sales Manager if you are interested in becoming an authorized SunWize representative at:

1-800-232-7652.

Visit our website at:
www.sunwize.com



SunWize uses Siemens' high-quality solar modules which are certified worldwide and backed by the longest warranty in the PV industry - 25 years!



Complete Y2K Systems

SOLAR ELECTRIC

WIND ELECTRIC

PROPANE GENERATORS

(8KW available late May, limited supply)

INVERTERS

SOLAR EVAPORATIVE

COOLERS SPECIAL
SALE!

A Premier Manufacturer of Quality Solar Products

SUNAMP POWER COMPANY

7850 E. Evans Rd., S-104
Scottsdale, AZ 85260-6919



1-800-677-6527



Birth of a

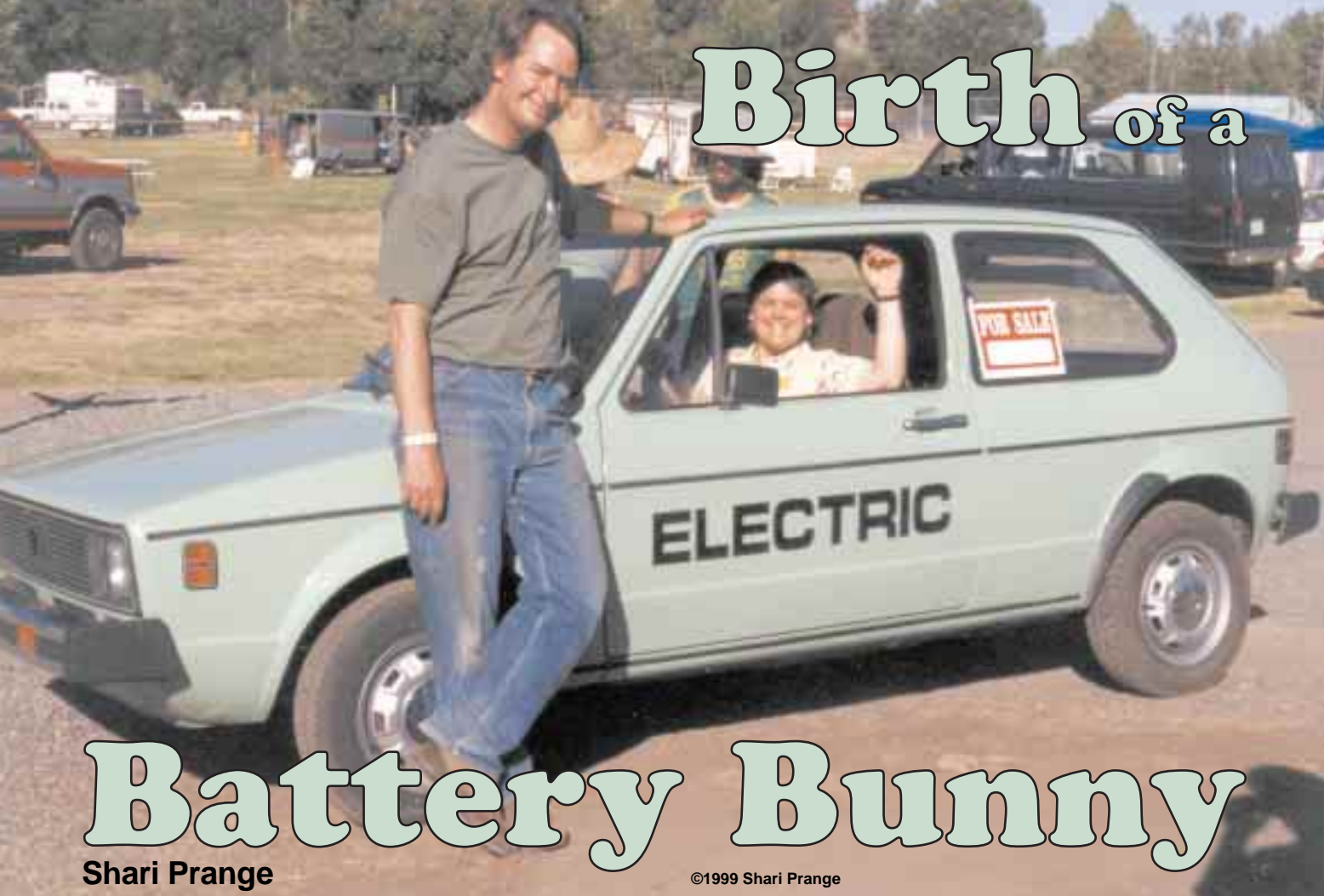

Battery Bunny

Shari Prange

©1999 Shari Prange

Jennifer and Lance Barker with the shiny new electric “Voltsrabbit” conversion, a SolWest demonstration event.

Lance and Jennifer Barker are true believers in renewable energy. Their 40 acre homestead outside of John Day, Oregon is completely off-grid, and Jennifer has authored a solar cookbook. They are also true believers in Volkswagens. Their fleet includes a Bug, a Bus, a Thing, and a single-cab pickup—not to mention a Rabbit or two lurking in the bushes. So maybe it was inevitable that these two interests would intersect one day.

Flirting with an Idea

Lance and Jennifer had wanted an electric vehicle for quite some time, and thought that a Rabbit would make a good candidate. When they learned about a particularly clean car available in Seattle, they jumped on it. “If you’re going to invest all the time and money in a conversion,” Lance said, “you want a nice chassis to

put it into.” This car needed a head gasket, but the body was cherry—albeit an apple-green cherry. It had good paint, with only one small dent, and a good interior as well.

After they purchased the car, Jennifer and Lance began to investigate electric conversions in more detail. They then came to the reluctant conclusion that it wasn’t practical for them. The road between their home and town was partly gravelled, and involved a substantial drop in elevation. Charging at home would require a larger solar array than they had. Being practical and realistic people, they agreed that it just wasn’t a workable plan for them at present.

Conception

But they still wanted to see the pretty little green Rabbit go really “green” as an electric. “I could’ve just fixed the head gasket and sold it,” Lance said. “But you don’t often find a Rabbit in this good shape, and I felt it really should be an electric.”

About this time, Jennifer and Lance founded the Eastern Oregon Renewable Energy Association, and began to organize the First Annual SolWest Renewable Energy Fair. Was there some way they could work the

car conversion into the fair? On the recommendation of Richard and Karen Perez, Jennifer emailed Mike Brown of Electro Automotive in California and asked about the possibility of doing a conversion on the car as a public demonstration at the fair.

Fortuitously, the car was a Rabbit, which was one of only two models (the other being the Porsche 914) for which a complete custom pre-fabricated kit exists. It would not have been possible to do a public demo conversion in just a few days if parts also had to be designed and fabricated.

Details were worked out, and the conversion project was on! The kit was shipped to John Day in advance, and Jennifer arranged a discount on batteries from the local Interstate dealer. The entire community got behind the project, donating work space, tools, and helping hands. Jennifer also got sponsorship from Redline for low friction transmission fluid, and from the Tire Rack for a discount on low rolling resistance tires. The project, and the fair as a whole, began to come together.

Pre-Natal Care

Preparations began on the car a couple of weeks before the big event. Lance installed heavy duty springs and shocks front and rear, and freshened up the axles. Jennifer applied touch-up paint to a few scratches and waxed the whole car until the paint looked new.

The Electro Automotive contingent arrived on Tuesday, just as Lance and Jennifer were preparing to move the car into town, a distance of about twenty miles (32 km). The problem was that the car didn't run, and didn't have any brake lights or turn signals. However, a transport convoy was established. Jennifer would drive the Bug, towing the rabbit. Solar Man Phil Wilcox would ride shotgun. Lance would steer the Rabbit at the end of a tow strap, and Mike and I would follow in a pickup to provide warning lights. Kids, don't try this at home!

To avoid the long, steep downhill and traffic of the main highway, most of the journey was done on empty gravel back roads. And, just to make life more interesting, it began to rain. After slowly climbing to the top of the pass, Jennifer pulled over, unhitched Lance, and got out of the way. The Rabbit began to roll, gained speed, and soon disappeared downhill.

The rest of the convoy followed, peering around each curve—and over the steep side of the road—for a glimpse of Mr. Toad on his wild ride. Finally, just before the back road joined the highway, we caught up to Lance where he had stopped, grinning with the exhilaration of finding himself still alive. The car was rehitched and towed the rest of the way into town at a more sedate pace.



Hoisting out the internal combustion engine.

First Labor Pains

The SolWest fair, held at the Grant County Fairgrounds, didn't open until Saturday. But there was work to be done on the car before then. So space was secured at the Auto Shop just a couple of blocks from the fairgrounds. Over the next three days, all of the dirty internal combustion system was stripped out of the car. In addition to the engine, this included the entire fuel system, cooling system, and exhaust system. The work

Results of the IC component-ectomy.





Lowering the new electric motor into place.

crew included Mike Brown, Lance, and Humberto Moro, who had traveled to John Day from Guadalajara, Mexico, just to volunteer for the conversion.

Next came pressure washing to clean the engine bay and the transmission. Then the crew began cutting and drilling the various holes needed. The spare tire well behind the back seat had to be cut out to accept the rear battery rack and box. Some sheet metal had to be cut in front to provide clearance for the front battery rack, and holes were drilled for cables and other components.

By Friday afternoon, when the car was towed (by a real tow truck) to the fairgrounds, the rear battery rack was in place. Also, the 2/0 (67 mm²) power cables from the front to the rear of the car were installed underneath

An aluminum and steel adaptor system mates the new electric motor to the standard transmission.



inside a length of flexible PVC hose mounted with riveted brackets and clamps. All the vestiges of its former life as a gas car were gone—even the factory lettering on the hatchback—and the Rabbit was ready to receive its new drive system.

The “delivery room” at the fairgrounds was a 20 by 20 foot (6 x 6 m) expanse of floor in the middle of the pavilion, with other exhibitors lining the walls. The conversion was the first thing people would see as they entered from any door. The actual work area was blocked off with yellow “Caution” tape and stanchions, but visitors to the fair could gather outside the tape on three sides of the car, just a few feet from the action.

A low platform stretched along the driver’s side of the car, with all the electric drive components, neatly labeled baggies of hardware, and tools carefully laid out for the “delivery” team. Beyond the platform, I was in charge of tables of informational literature and posters, and of course, answering the many questions people had. To the rear of the conversion area, all of the dirty internal combustion parts that had been removed were spread out on display: the engine hanging from a hoist, the gas tank, radiator, exhaust system, and piles of unidentifiable grimy pieces that were no longer needed.

Complications in the Delivery

The little bunny had a couple of surprises in store. The first complication actually occurred at the Auto Shop on Friday. When the time came to install the clutch on the motor and adaptor, it didn’t fit. The new clutch parts Lance had bought didn’t match the old clutch parts and flywheel. Rabbits have two different clutch sizes. Theoretically, you can tell which size your car has by its year, but in real life, you can’t be sure until you take it apart.

John Day is a very small town, and it’s a long way to a big town where the right clutch could be bought. Fortunately, the old clutch was still in good condition and not very old, so it was re-installed.

Another surprise was more serious, and reared its head on Saturday, when the conversion was underway at the fairgrounds. Rabbits come in two versions, the early ones (’74–’79) built in Germany, and the late ones (’81–’84) built in Pennsylvania. This car, however, was a 1980, a transitional model that’s neither fish nor fowl. Some parts of it are early, some are late, and some are for that one year only.

In this case, the dash didn’t match either early or late versions. The place where the new gauges and circuit breaker were supposed to mount simply didn’t exist. Oops! This is the kind of thing a hobbyist converter might run into and have to spend a few days working

The Battery Bunny's Power System

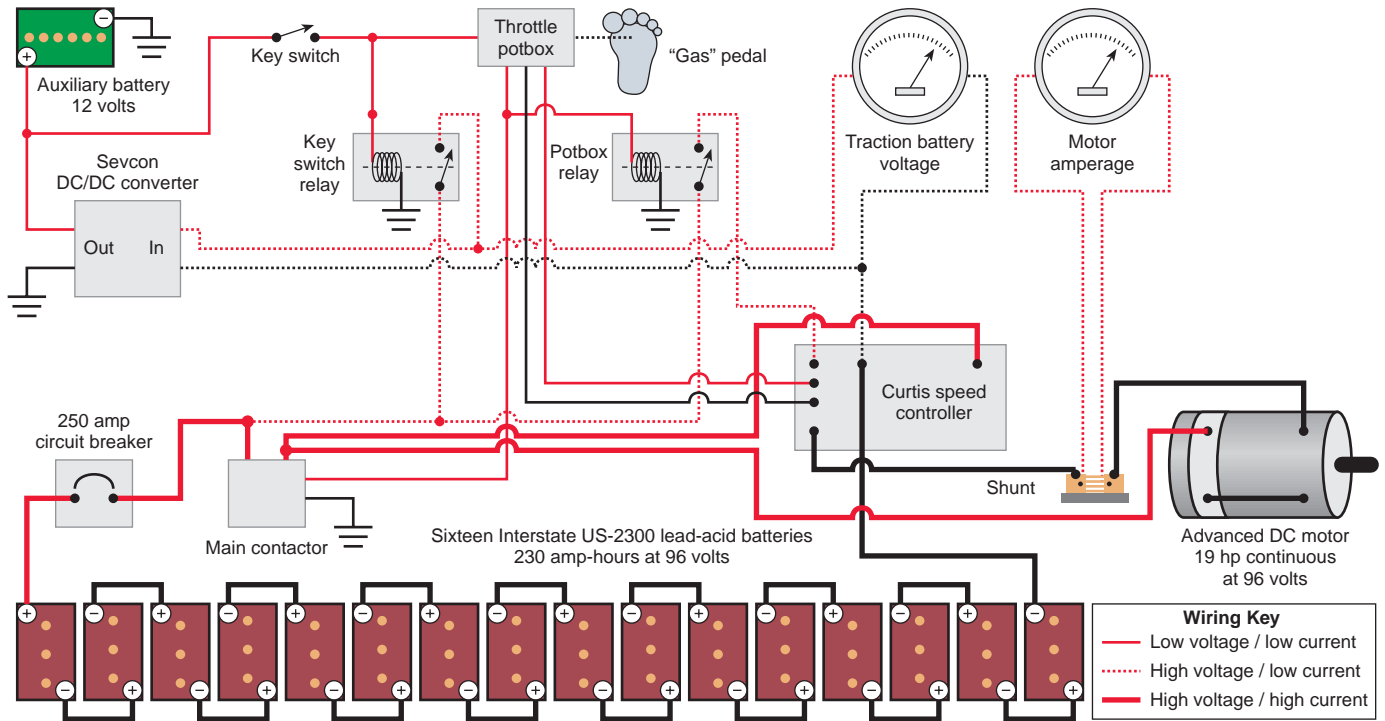

out, but we didn't have a few days to spare. Luckily, a couple of local talents, Doug and Bubba, took the pieces home Saturday night and came back the next day with a modified mount that worked.

A third surprise lay in wait under the hood. In a late model Rabbit, the rectangular headlights have to be remounted on a special metal plate that sets them forward two inches (5 cm), to allow clearance for the controller in the kit. The early Rabbits have round headlights that don't interfere. This car had rectangular headlights that interfered with the controller by a couple of inches, but the late style modification plate wouldn't fit. Instead, the controller's heatsink was modified to allow the controller to move back a couple of inches.

A Team of Midwives

During the fair, various volunteers came to work on the car for a couple of hours at a time. The crew worked in the middle of the pavilion floor as the crowds of visitors swept around them and paused to watch the transformation in progress.

The eight inch (20 cm) Advanced DC motor was mounted to the original four-speed manual transmission with an adaptor. Other components were installed around the periphery of the engine bay (now a motor bay), including a Curtis speed controller, throttle potbox, vacuum pump and reservoir for the power brakes, and a Sevcon DC/DC converter to keep the 12 volt

accessory battery charged. The car's original 12 volt battery was replaced with a smaller one to make room for the front battery rack. This was possible because the 12 volt battery would no longer be required to start the car. Its only duties were to supply power to the lights, horn, and accessories.

The front battery rack was a complex shape in order to hold eight 6 volt batteries. Four of them sat in a nice square block above the motor and offset toward the passenger side of the car to clear the vacuum brake system. Then the rack dropped to a second level a few inches lower and extended across the front of the car, just behind the grill. Clearance was so tight that one battery sat sideways to the others, and the end one was offset a fraction of an inch from the rest of the line.

Congratulations! It's a Bunny!

The anticipation grew as the crew prepared to install the rear battery pack. "Is it going to run now?" spectators asked repeatedly, loitering nearby. A welded polypropylene box was lowered into the rack and fitted with forced air ventilation to remove gasses during charging. The eight rear batteries were installed.

The entire 96 volt pack would be charged by way of a male electrical plug emerging from the former gas fill opening, through a cord to a Russco 110 volt charger tucked into the left rear corner of the car. When the "gas" cap is removed, a short cord and outlet appears.



After the conversion, it's mostly batteries under the hood.

A normal 12 gauge extension cord is then plugged into this outlet, and into a regular 110 volt household outlet in the wall of the garage. This is the umbilical cord that feeds the car its "juice."

As a finishing touch, large letters proclaiming the car "ELECTRIC" were added to both doors, and the original "Rabbit" sign on the hatchback was replaced with one reading "Voltsrabbit."

At 5 PM on Sunday, as the fair was coming to a successful close, the moment of truth came. All the connections had been made and voltages checked. With the front wheels off the ground for safety, Jennifer took the driver's seat, turned the key, and stepped on the throttle. The main contactor closed, the motor spun up with a soft whine, and the wheels turned as cheers and applause rose from the crew and spectators.

The car was lowered to the ground, and Lance joined Jennifer for the maiden voyage. The green Rabbit glided silently out of the pavilion and quickly disappeared, trailing a small crowd. After a victory spin around the town streets and fairgrounds, Jennifer and Lance returned to the pavilion, sporting the unmistakable smiles of new EV drivers. "It really moves, too!" Jennifer said. "I got it out on the street and punched it, and it jumped up and went 'Wheeeee!'"

EV For Adoption

Jennifer and Lance know they can't keep the bunny, but they're happy that it's now electric, and hope to find it a good home. It has a top speed of about 65 mph (105 kph), and a range of 60–80 miles (100–130 km) on a charge in good conditions, somewhat less with hills. They're asking US\$10,000 for it, with anything above their costs to go to EORenew.

They're already making plans for next year's energy fair. And they're reluctant to completely give up their dream of an electric car for themselves. Maybe, with a different chassis, and a higher voltage system, just maybe...

Access

Author: Shari Prange, Electro Automotive, PO Box 1113-HP, Felton, CA 95018-1113 • 831-429-1989
 Fax: 831-429-1907 • shari.prange@homepower.com
 www.electroauto.com

Lance & Jennifer Barker, PO Box 485, Canyon City, OR 97820 • 541-542-2525 • solwest@eoni.com
 www.eoni.com/~solwest

Our thanks to the companies who donated time, service, or equipment for the EV conversion:

The Auto Shop, John Day, OR—work space to tear the engine out, and engine hoist.

Doug's Motor Vehicle Repair, John Day, OR—batteries and parts at cost.

Gene Salada, John Day, OR—use of engine hoist and creeper.

Interstate Batteries, Boise, ID—batteries at cost.

NAPA Auto Parts, John Day, OR—wheel paint and use of jack stands.

Red Line Synthetic Oil, Benicia, CA—lubricants.

The Tire Rack, South Bend, IN—discount on tires.

100% Cotton Good Shirts!

T-Shirts

Sizes:
S, M, L, XL, XXL

**Full Color on Natural Shirt
\$15.00**

International orders add \$5 for air shipping

To Order Call: 800-707-6585

(541-512-0201 Outside USA)

Or see our web site:
www.homepower.com

Or send check or money order to:
Home Power Magazine
 PO Box 520, Ashland, OR 97520

Available Now! Only \$25 (outside USA add \$10 for air-mail shipping)

THE NEW ELECTRIC VEHICLES

A Clean & Quiet Revolution
by Michael Hackleman

Journey into the world of conversions, scratchbuilts, human-electrics, solar cars, electrathon racers, planes & boats—all powered with electricity.

272 pages of EV technology, 465 photographs (over half in color), and detail on 65 vehicles. Includes 115 technical design and construction sidebars.

To order Call: 800-707-6585

Outside USA call 541-512-0201 • Fax: 541-512-0343

or write to:

Home Power Publishing
PO Box 275 • Ashland OR 97520



"It's
Electric!"

Are Alternative Energy Prices Turning Your Budget UPSIDE DOWN?

At Solar On Sale our one and only goal is to put alternative energy products in the hands of the masses, where they belong, for the lowest prices possible!

Trace SW4024 \$2279.00
Heart 2 KW w/ Charge \$699.00
ProSine 2.5-12 \$1619.00
ProSine 3.0 \$2079.00
Trace SW4048 \$2259.00
Kyocera KC120 \$549.00
Trace PP-SW4024/S \$3369.00
Trace DR1512 \$699.00
Photowatt 75 watt PV \$318

Trace PP-SW4024/D \$5759.00
Trace DR2424 \$969.00
Solarex VLX-53 \$239.00
1000 watt Inverter \$199.00
Trace SW5548 \$2799.00
Danby Propane Fridge \$805.00
500 watt Inverter \$99.00
Heart 2.5 KW w/ Charge \$850.00
Photowatt 100 watt PV \$425

SOLAR ON SALE

Toll Free 1-888-64-SOLAR (76527)

<http://www.solaronsale.com>



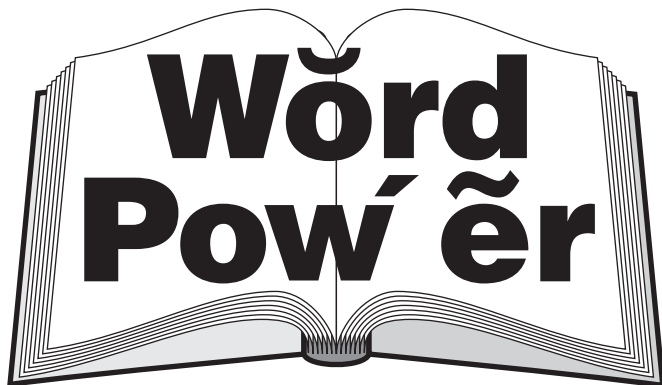

Renewable Energy Terms

Battery— Electrochemical Energy Storage Device

Ian Woofenden

©1999 Ian Woofenden

Derivation: The word "battery" is originally from an Old French word meaning "to beat." It later came to mean a physical confrontation ("assault and battery"), then a group of weapons ("a battery of mortars"), and finally a group of other things ("a battery of tests"), including electrochemical cells.

One reference book suggests that there's also a connection between a weapon discharging and a battery discharging. Today many people use the term to mean not only a group of cells, but also an individual cell ("flashlight battery"), stretching the word's meaning once again. Many technical people think that "battery" should only be used to designate a group of cells.

A battery in a renewable energy (RE) system is an energy storage device. Stick with me while I suggest a new analogy for this device. We often compare electricity to hydraulics, and electron flow to water flow. To carry this analogy further, you can think of a battery as an electron pump. But this pump not only drives electrons, it is driven—or charged up—when the electrons flow in the other direction. Imagine a spring-loaded, wind-up water pump that sends water out to a faucet as it unwinds, but can also be wound up by driving the water back through it. Instead of water, a battery pumps electrons.

When a battery is powering a light bulb, the electrons flow in a loop, through the battery, to the the load, and back through the battery. How much water does a wind-up water pump store? None. How many electrons does a battery store? None.

A little wind-up water pump could be wound up to its maximum capacity by pushing a certain number of

gallons through it. Yet the little wind-up water pump does not store any water at all, since the water is pumped *through* it. It's the same with a battery. A battery does not store electrons. It stores potential energy in a chemical form. The wind-up water pump stores potential energy in the spring.

Batteries are direct current (DC) devices that store chemical energy. This chemical energy is based on electrical energy, but there is a difference. Electrical energy can be accessed directly (as in discharging a capacitor), while chemical energy requires a chemical reaction to access the energy. If we let a battery run all the way down to zero charge, then its chemical reaction has been completed in one direction. When we charge the battery, the chemical reaction runs the other way. When this reaction is complete, we say the battery is "full." A certain number of electrons have been pumped back through the battery. The battery is now ready to supply energy by moving the electrons in the other direction, doing work in the process.

Of course, this isn't a perfect process. Some energy is lost to heat and other inefficiencies. Generally speaking, we get about 80 percent out of the battery for whatever we put in. And we're limited to what our renewable energy systems generate.

Our neighbors on the subsidized utility grid have an unlimited supply—they can leave the hose running full blast all the time, though they'll see it on the bill. We have only what our spring-loaded pump will store—whatever energy our renewable energy systems have generated. This is why we have to be very careful not to lose our limited supply of energy through wasteful appliances and lights, or through carelessness.



Access

Author: Ian Woofenden, PO Box 1001, Anacortes, WA 98221 • Fax: 360-293-7034
ian.woofenden@homepower.com

My thanks to Bill Beaty for the inspiration for this column. Check out his fascinating Web site (www.amasci.com/miscon/miscon.html) on scientific misconceptions.



LOWEST PRICES UNDER THE SUN!

<p>5555 Santa Fe St. #J San Diego, CA 92109 USA (619) 581-0051 (619) 581-6440 fax TOLL FREE 1-800-842-5678 e-mail: solar@cts.com http://www.solarelectricinc.com</p>	 SOLAR ELECTRIC INC.
	<p>UNI-SOLAR PowerStar <small>and many other fine products...best selection!</small> SATISFACTION GUARANTEED!</p>

New MPPT Controller!

SOLAR BOOST™-50

Stop throwing your Money and PV Power Away with other controllers that can't deliver full charge current potential. New patent pending **Maximum Power Point Tracking (MPPT)** technology will extract more power from your PV array. This easily installed device will **increase your available charge current up to 30%**.

Solar Boost 50 is a 12/24 V photovoltaic (PV) charge controller capable of delivering 50 amps of output current. MPPT technology allows Solar Boost 50 to extract more power from the PV array, resulting in a charge current increase up to 30% or more.

Solar Boost 50 offers an advanced automatic three-stage charge control system to ensure that all battery types are properly charged to full capacity. Electronic current limit feature prevents output current from exceeding 50 amps. Output current limit eliminates worry about overload when PV output is unexpectedly high.

An optional user-friendly digital display shows battery voltage, solar current, boosted charge current, charge mode, and state of charge. It can be provided in the controller, as a remote panel, installed up to 300 feet away, or both.

- ◆ Increased Charge Current = Fewer PV Panels
- ◆ Optimize Charge Parameters To Battery Size & Type
- ◆ Available Temperature Compensation
- ◆ Available Digital System Monitoring
- ◆ Full 36 Month Limited Warranty
- ◆ Electronic Current Limit Prevents Overload
- ◆ Pulse Width Modulation Control
- ◆ Three-Stage Battery Charging



Solar Boost 50 – US\$299.00

Global Power Systems

31739 Riverside Dr., Suite L, Lake Elsinore CA 92530
Phone: 909-245-8040 • Fax: 909-245-9611

Also available the **Solar Boost 2000** as featured in **Home Power**. The Solar Boost 2000 features **20 amp MPPT** multi-stage charge regulation with digital system monitoring for smaller PV applications.
SB2000 – US\$229.00



These Quality Products Are Manufactured By RV POWER PRODUCTS, Encinitas, California

Wind & Sun

Serving customers around the world for over 20 years

Partial list of manufacturers

Astropower - Unisolar - Kyocera - Solarjack & Sunrise submersible pumps - Thin-Lite - Concorde AGM batteries - Siemens panels - Two Seas Mounts - Solarex Deka Industrial batteries - Surrette batteries - Trace - Statpower - Morningstar - BP Solar - Shurflo pumps - Exeltech - TriMetric - Zomeworks tracking mounts - Fire Wind & Rain maximum power point trackers - Solar Converters Inc. - Heliotrope - Delta Lightning arrestors - Dankoff solar pumps – and many others.

Summer-Fall Sale

These prices good through October, 1999 - See our web sites for many more specials.

Siemens SP75 - 75 watts, 25 year warranty: \$365 each for box of 2 or more

Kyocera KC120 - 120 watts, 20 year warranty: \$599 each

Unisolar US64 - 64 watt thin film triple junction: \$295 each

Trace SW4024 or SW4048 4kw sine wave inverter: \$2395

Trace DR3624 3600 watt modified sine wave inverter: \$1139

Trace DR2424 or DR2412 2400 watt modified sine wave inverter: \$995

Trace TS512SB Tiger series 500 watt with charger: \$395

BP Solar BP275 75watt, 20 year warranty, \$375

All trace SW power panel systems on sale – up to 30% off!

Prices do not include shipping. We accept all major credit cards.

Get our set of 3 - Catalog, Solar Design Guide, and Solar Water Pumping Guide for only \$7.50 postpaid.

See our online catalog and complete guides to solar at www.windsun.com

www.solar-electric.com (online store)

Northern Arizona Wind & Sun, Inc.

Phoenix, AZ

888 881-6464 - Fax: 623 872-9215

2725 E Lakin Dr., Flagstaff, AZ 86004

800 383-0195 - Fax: 520 527-0729



Mike Brown

©1999 Mike Brown

“What do I have to do to the car’s suspension to compensate for the added weight of the batteries?”

This question always comes up during the electric vehicle conversion process. It’s easier to deal with if it comes up early in the design/planning stage, rather than when the completed conversion is sitting on its original suspension, fully loaded with batteries. When this happens, the car is often sitting high on one end and low on the other. Or it’s down to the bump stops on both ends, looking like a lowrider, with no way to get a jack under it to raise it and fix the problem.

Gross, Curb, and Axle Weights

The suspension modification process starts before the conversion process. If the donor car is still running, take it to a public scale and weigh it. Take one wheel with just the front wheels on the scale, then pull it all the way onto the scale for the total weight, and finally pull the car forward until only the rear wheels are on the scale and weigh that end.

If the car doesn’t run or you can’t locate a scale, find the gross vehicle weight (GVW) and the gross axle weights (GAW) given on a sticker on the driver door jamb. The gross weights represent the maximum allowable weight for the vehicle with passengers and cargo, fully loaded. Use these numbers to figure the front-to-rear weight distribution percentages.

Then, find the curb weight of the car in the owner’s manual, factory manual, or a car magazine road test. This is the actual weight of the vehicle itself, unloaded. Use this number to calculate the front and rear axle curb weights according to the previous distribution percentage.

Next, subtract the measured or calculated axle curb weights from the GAW, and find out how much weight capacity you have to play with. In such calculations, I disregard the difference between the internal combustion (IC) parts removed and the electric vehicle (EV) parts that replace them as there isn’t that much

difference. For a VW Rabbit, the electric conversion components (not including batteries) weigh only about 190 pounds (85 kg) less than the IC components that are removed.

Compare the weight and location of the batteries in your proposed battery layout to the amount of carrying capacity available. This will tell you how much you will have to beef up the springs to accommodate the batteries. It might also point out that putting all the batteries in one place because you have the available space could lead to a dangerous overload. This could be avoided by spreading them throughout the car in smaller packs, and maintaining the original front-to-rear weight balance, even though you are carrying more than the original total weight.

Ride Height

The second thing to do before you start to convert the car is measure the ride height. Returning the car to its original height after the conversion is important because the wheel alignment specifications are based on the car being at a specific ride height.

The easiest way to take this measurement is to run a tape measure from the ground up past the center of the wheel to the bottom of the wheel opening in the fender. Do this on all four wheels. There will be some difference in these measurements front-to-rear and side-to-side. If you know what these were before the conversion process takes place, it will be clear whether any differences found afterwards were there originally, or were introduced. If there is a difference of two inches (5 cm) or more side-to-side, check for possible frame damage from an accident.

Record the results in your project notebook, along with the weights we talked about earlier. Keeping a project notebook with important numbers like this prevents frantic searches months later for the scrap of paper you wrote them on when you did the measuring.

Re-measure After Conversion

After the conversion is done, drive it back and forth a short distance to settle the suspension, measure the ride height again, and record the new measurements in the project notebook. Look at the EV. It may have one end higher than the other, or it may look like a “lowrider,” with both ends at the same level. Is the difference from front to rear not too radical? Is there still some give in the suspension? Is there free movement of the wheels with no interference between the tires and the body or frame?

If so, and if the public scale you used at the start is close by, you might carefully drive the EV to it and repeat the weighing process.

If the EV is undrivable, you will have to work with an estimate of the amount of weight added and the measured amount of ride height lost to determine how much the load carrying ability of the suspension must be increased. When we were developing our Voltsrabbit kit, we had new springs made based on the amount of ride height we needed to recover and the weight of the batteries added to the front and rear of the car.

Coil Springs & McPherson Struts

Now that we know what we have to do, how do we do it? For cars with coil springs or McPherson struts, the first place to look is your car's manufacturer. Is there a heavier model in their lineup whose springs might interchange? The wagon version of your coupe will have heavier duty springs. Use the dealership parts department to identify which springs you want, but search the wrecking yards, as they will most likely be expensive special order items at the dealership.

A second option is the aftermarket. Your local parts house will have catalogs listing heavier duty springs for applications like trailer towing or increased load carrying ability. See what they might list for your car. (Note: if during all of this research you find a friendly, helpful, and knowledgeable parts man, a bag of chocolate chip cookies goes a long way toward keeping him that way.)

The remaining possibility is the most expensive but most effective way to handle the increased weight: custom springs. Custom spring manufacturers can be found in the Yellow Pages of most major cities under the heading *Springs; Automotive*.

The spring shop will want to know how much you want to raise the car, how much weight was added, the spring rate of the existing spring, and what style ends the spring has. You can supply the first two from your measurements and weighing sessions, and the last two by sending one each of your old springs as an example. Given the data and examples, a good spring shop can wind you a bolt-in replacement spring that will restore your ride height and handle the increased load. Expect to pay from US\$150 to \$200 per spring.

Don't Go There

There are also some options you should *not* use to increase the car's weight carrying capacity. Coil spring "helpers" sold in chain auto parts houses and mail order catalogs are metal blocks that are wedged between the spring's coils to keep them from compressing under load, in theory at least. In fact, they usually fall out when the car hits a big bump or gets jacked up. Besides, even if they stayed put, they are effectively preventing the spring from doing what it is supposed to do, which is compress and expand.

Avoid "racing springs." These are almost always designed to lower the car, at the same time providing enough spring rate to keep the tires firmly planted on the track. This is something that the EV, with its increased weight, doesn't need help with.

A word about handling McPherson struts: The springs are held on the strut under high compression by one nut. Never attempt to remove that nut without securing the spring in a suitable spring compressor. The sudden release of spring energy can result in severe injury. Take the struts to a shop that can work on your make of car and have them change the springs. At the same time, install new heavy duty shock absorber inserts (more on shock absorbers and inserts later), using the specialized tool they have for that purpose.

Leaf Springs & Air Shocks

For cars and trucks with leaf spring rear suspensions, start by searching at a dealership parts department for springs from a heavier duty model of the same car or truck. The aftermarket parts house is also a good source, especially for trucks, as there are several companies that make overload spring kits for trucks. (These may also be called "helper" springs, but unlike coil "helpers," these actually work. Get good ones, not cheapies.) The custom spring option is still available if all else fails.

An option for leaf spring and some coil spring rear suspensions is the air shock. This is a shock absorber with an air bladder built over it which, when inflated, adds load carrying ability. They will work on coil spring suspensions as long as the shock absorber does not run through the center of the coil spring. I used air shocks on one tail-heavy car to raise the rear end to the original ride height. In the process, the front ride height dropped back to exactly where it was supposed to be. The car was driven daily for ten years and there were no problems with the air shocks.

Torsion Bars

For vehicles with torsion bar suspensions, such as air-cooled VW and Porsche products and some Japanese pickup trucks, things are a little different.

For Bugs, the front torsion bars aren't easily adjustable. Heavy duty coil springs that fit over the shocks are available, and can be installed to help the torsion bars. (Super Beetles don't have torsion bars, they have McPherson struts, which we addressed earlier.)

The Bug rear is adjustable by changing the position of the inner and outer splines of the torsion bar. Heavier duty rear bars are available from aftermarket suppliers. However, in my opinion, the rear suspension is best handled with air shocks.

The Porsche front bars have an adjustable stop, and heavier bars are available if you need more load carrying ability. With the exception of the 914, the rear bar adjustment is similar to the VW, and aftermarket bars are available. The 914 doesn't have rear torsion bars, but aftermarket heavy duty rear coil springs are available to replace the stock ones.

The front torsion bars of Japanese pickup trucks are adjustable, and since most of the batteries go under the bed of the truck, this adjustment is usually enough. If, however, the bars are adjusted as far up as they will go and you haven't got your ride height back, a search at the dealership parts department and aftermarket parts house might be in order.

Shock Absorbers

Another part of all the suspension systems mentioned above which requires attention is the shock absorber. The term "shock absorber" is a misnomer. A shock absorber is really an oscillation dampener. When the springs, which are carrying the weight of the car, compress and expand to diminish the effects of bumps in the road, the shocks provide resistance to the springs' natural tendency to continue compressing and expanding.

Since the springs in an EV are carrying more weight, it's a good idea to have a heavier duty shock absorber. I use the KYB brand gas-filled shock absorber in my cars, but any major brand of gas-filled shock will do. Replace all four shocks when you are doing the rest of the suspension modifications to keep from having to do parts of the same job twice. On cars with the McPherson strut suspension, you might have to buy the whole strut with the gas-filled shock built in.

Do It Right!

Suspension modification is not the most glamorous part of the conversion process, but it is one of the most important. A properly modified suspension makes the difference between a safe, usable, pleasant-to-drive EV and a monster that nobody could love.

This has been an overview of a complex subject and I could not possibly cover it in full detail. If you have a specific problem, contact me and I'll see if I can help you.

Access

Mike Brown, Electro Automotive, PO Box 1113-HP, Felton, CA 95018-1113 • 831-429-1989
 Fax: 831-429-1907 • mike.brown@homepower.com
 www.electroauto.com



New BULLDOG Generator Sets
 Diesel, Propane & Natural Gas
 Local Service Support
 No Waiting Six Months for Parts



New 3.5 KW Diesels from: \$1,795
 (not model shown)

BOWERS POWER SYSTEMS
 Seattle, Portland & San Francisco
 Ph 800-858-5881 • Fax 888-246-2935
 www.bowerspower.com

"I consider (the PowerPulse® devices) to be standard equipment for a lead-acid battery system..."
 Richard Perez, Home Power magazine



Extend the life of your batteries!

12 Volt	24 Volt
\$69.95*	\$119.95*

Accept no substitutes; the cost effective **PowerPulse®** units are patented, approved by the U.S. Military, and have a 10-year limited warranty.

**Manufacturer's suggested retail price. Other voltage units available.*

- Free delivery to 50 States. ■ Major credit cards OK.
- Bulk/Dealer inquiries invited.

Abraham Solar Equipment
 800-222-7242 ■ 970-731-4675
 124 Creekside Place ■ Pagosa Springs, CO 81147
 ©1999 Abraham Solar Equipment. All rights reserved.

THE POWER BROKERS!™

You don't need a battery system monitor to get your renewable energy system to work!

Every system needs one to keep it working well.

A monitor will show when you need to recharge your batteries before the inverter shuts off your power.... much better for your batteries!

You'll save energy by becoming familiar with how much your appliances draw. A monitor will reveal "phantom loads" that steal power 24 hours per day.... and it could help you save more energy than one solar panel will produce—at about half the cost.

If something isn't working right it will help you discover what's wrong.

And the **TriMetric** will remind you to charge (and equalize) the batteries if they haven't been fully charged for a number of days (You program the number of days). Your batteries will like this too!

under \$200 with shunt

Ask your R/E dealer or visit our web site for more info.

BOGART ENGINEERING

19020 Two Bar Road, Boulder Creek, CA 95006

(831) 338-0616

www.bogartengineering.com

The **TriMetric** TM-2020



Measures: battery volts, amps, % full (based on amp-hours), battery lifetime total amp-hours, highest battery voltage, lowest battery voltage, days since charged, and days since equalized.

SIEMENS



Solar Power Your Dream.

You've finally found just the right spot. A little out of the way, but good water, good soil, and even a little view. You're going to build.

Find out now just how easy it is to have a solar system to meet all or part of your electrical needs.

See Your Siemens **SolarPowerPro**™

Siemens can help turn your plans into reality. An economical Siemens solar system can give you year after year of trouble-free electricity. And do it silently, without fuel, waste or pollution.

Office (520) 636-1001
Fax (520) 636-1664

P.O. Box 365, 2655 N. Hwy 89
Chino Valley AZ 86323



Creative Energy Technologies BLOW-OUT SALE



Tankless Water Heaters

Models: 125X \$609, 125B \$519, 125BS \$609, 170 \$899



Composting Toilets

Model Y2K (Non-electric version of XL) \$899



Refrigerators

BSKF375 \$949,
SE215 \$649



Solar Charger Kits

BPRV90 (includes 90 watt panel, 15 amp analog metered charge controller, mounts, wire, instructions) \$649



SW4024

sinewave inverter / charger,
4 kilowatt, 24 V, \$2389

SIEMENS SR100 100 watt solar module \$489

check us out on the web at: www.cetsolar.com

Or call for our catalog **888-305-0278 Toll-Free**



10 Gertys Path/off Yankee St.,
PO Box 304, Summit, NY 12175



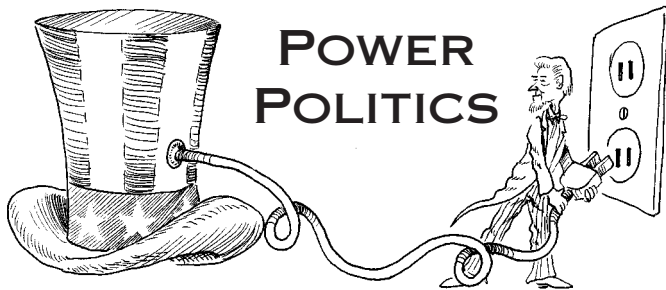

Community Choice

Michael Welch

©1999 Michael Welch

Environmental and consumer advocates agree that our nation's first experiment in utility deregulation is a dismal failure. California's law has become a model of how *not* to do utility deregulation.

The list of problems with the legislation and its implementation is long:

- Nuclear financial bailouts,
- Not enough funds for renewables and other public purpose programs,
- Confusing billing,
- Rate decreases paid for by consumers, but costing more than the actual decrease,
- "Green" power that results in other consumers' power being more brown, and
- The list goes on....

In addition to these problems, one of the most far-reaching consequences of California deregulation has been a lack of community choice built into the law. It's been more than a year since the law was implemented, but less than one percent of public utility customers have switched energy providers. Of course, this is what the utilities had hoped for. It was even encouraged by making the utility-run (but consumer-funded) deregulation information campaign one of the most confusing and misleading PR campaigns in history.

As I predicted in this column long ago, the only ratepayers that significantly benefited from California

deregulation were the biggest utility customers. Residential and small business customers have little to gain by changing energy suppliers. Fortunately, other states are learning at least something from California's across-the-board failure.

Community Choice in Ohio

Ohio Senate Bill 3 was passed by the legislature and then signed by Governor Bob Taft on July 6th. A key provision in this law is the offering of community choice, a provision modeled after part of the Massachusetts utility deregulation law. Community choice enables consumers to use local governments to get together in more powerful buying groups. It gives them access to the same sweet deals that large utility customers (such as manufacturers) get by allowing negotiation on behalf of groups of consumers.

A city or village council can pass an ordinance, or a board of county commissioners or township trustees can pass a resolution, saying that they want to form a buying group. The ordinance or resolution can state that the buying group will automatically include all consumers in the community. Individual consumers can opt out of the buying pool and go shopping on their own if they choose.

As other state utility restructuring laws avoid California's horrendous mistakes, it becomes more likely that the coming Federal restructuring bills will follow suit, even including community choice. According to Wenonah Hauter of the Critical Mass Energy Project, "Making deregulated markets truly competitive, and truly beneficial to consumers, is not a left or right wing proposition.... Now that the truth is coming out about the benefits of community choice, it has strong bipartisan support."

Critical Mass and local pro-consumer groups now realize what must be done to make deregulation work for consumers in other states and nationally. Strong support for community choice didn't just happen because the utilities and large manufacturers automatically rolled over. It resulted from an intense political battle, waged largely beneath the surface over the past year as activists focused their efforts on educating city, town, and county officials. "Six months ago, no one in Ohio had heard of community choice," said Jennifer O'Donnell of Ohio Citizen Action, which led the organizing effort with the Ohio Consumers' Counsel, Ohio Partners for Affordable Energy, and RAGE.

O'Donnell said the strategy was to persuade local officials—who are the key element in making community choice work—to demand that solution. "The key challenge was to make local officials realize what

this could mean for their communities and get them involved in the deregulation debate.”

Federal Deregulation Debate Continues

A bill to protect consumers and the environment as electric utilities are deregulated was introduced in Congress on July 30, by representatives Dennis Kucinich (OH), Jan Schakowsky (IL), Luis Gutierrez (IL), and Tammy Baldwin (WI). The legislation protects consumers against price gouging, cost shifting, increased pollution, and interruptions in electricity service.

HR 2645, known as the “Electricity Consumer, Worker, and Environmental Protection Act,” is endorsed by RAGE, a nationwide coalition of 190 environmental and consumer organizations. It has been introduced just as Congress is holding hearings on a range of complex issues related to how individual states are dealing with deregulation. The legislation creates strong protections against the anti-competitive behavior of utilities that have used their enormous clout at the state level to rewrite the laws for their own benefit.

Sponsoring Representative Kucinich said, “I look forward to working with Ralph Nader, hundreds of consumer and environmental groups, and my colleagues in the Congress to protect consumers and the environment.” Representative Schakowsky added, “This legislation insures that if deregulation happens, it must be done the right way. It must protect all consumers and the environment, and it has to ensure that electricity is safe and reliable.”

Unlike other deregulation proposals, HR 2645 does not force states to deregulate electricity markets. But where states do deregulate, the bill provides these safeguards:

- Creates standards for high-quality, affordable electricity service,
- Provides funds for universal service, low income, energy efficiency, renewable energy, and worker retention/retraining programs,
- Enables consumers to use local governments to aggregate into more powerful buying groups (community choice),
- Requires all power plants to meet the same standards for pollution,
- Separates regulated companies and competitive companies, eliminating cross-subsidies, self-dealing, and other abuses of holding companies,
- Limits market share of power plant owners,
- Protects consumer privacy.

As good as this bill is, the fact that it does not require states to deregulate may be its shortcoming. There seems to be a lot of momentum in Congress and the White House to shove some form of deregulation at the states. If that momentum is strong enough, then we could end up with legislation that dictates what states do to a large degree. It could force customers to pay for stranded assets like uneconomic nuclear power plants.

On the other hand, good legislation could absolutely prevent that and even force states to provide better green electricity choices. It is all very much up in the air, and it’s way too early to get a good handle on which way the political breezes are blowing.

Deregulation and Rivers

Public Citizen has come out with yet another interesting report which could become a part of the deregulation debate, *Dammed Deregulation: How Deregulation of the Electric Power Industry Could Affect the Nation’s Rivers*. Author Charlie Higley states that deregulation could have a very negative impact on our nation’s rivers and the lands and people near them.

Already we are seeing dams and the relatively intact ecosystems around them being put up on the auction block by utilities. Previously, these areas were closely controlled and monitored by agencies that regulated utilities. As these beautiful lands are sold off to unregulated companies, it will likely result in overdevelopment, logging, and other types of resource extraction.

Higley’s report argues for an end to designating hydro power as a renewable energy resource in deregulation legislation. He also wants to see an end to selling hydro as “green” electricity. Marketing of all hydroelectric power as “green”—regardless of how it is generated—misrepresents the harmful environmental impacts of dams on rivers. It could squelch the development of non-hydro renewables. Unless there are specific exclusions, policies to support renewable energy sources could benefit hydroelectric power, which is already competitive.

This report is a must-read for anyone who is concerned about hydroelectric power on the grid, under deregulation, and as “green” energy. You can download the report from *Home Power’s* Web site. It is chock full of information about PURPA (Public Utilities Regulatory Policies Act) and FERC (Federal Energy Regulatory Commission), both of which remain mysterious to many of us, in spite of their far reaching effects.

Access

Author: Michael Welch, c/o Redwood Alliance, PO Box 293, Arcata, CA 95518 • 707-822-7884

Power Politics

michael.welch@homepower.com
www.igc.org/redwood

Ohio Citizen Action, 614 West Superior Ave., Suite
1200, Cleveland, OH 44113 • 888-777-7135 (OH) or
216-861-5200 • Fax: 216-694-6904
aryder@ohiocitizen.org • www.ohiocitizen.org

Ohio Consumer's Council, 77 South High St., 15th
Floor, Columbus, OH 43266-0550 • 877-742-5622 (OH)
or
614-466-9605 • Fax: 614-466-9475
occ@occ.state.oh.us • www.state.oh.us/cons

Ohio Partners for Affordable Energy, PO Box 1793,
Findlay, OH 45839-1793 • 419-425-8860
Fax: 419-425-8862 • drinebolt@aol.com

R.A.G.E. and Public Citizen's Critical Mass Energy
Project, 215 Pennsylvania Ave. SE, Washington, DC
20003 • 202-546-4996 • Fax: 202-547-7392
cmep@citizen.org • www.citizen.org/CMEP/RAGE
The Higley dam report:
www.citizen.org/press/pr-cmep16.htm



RAISING TOWERS? GET A GRIP!

As seen in the article by Paul Gipe in
December 98/January 99 issue

Griphoist-Tirfor® - safe and reliable hoist.

Works in any position:
horizontal, vertical, or angled
Capacity 2,000 lbs. - 8,000 lbs.

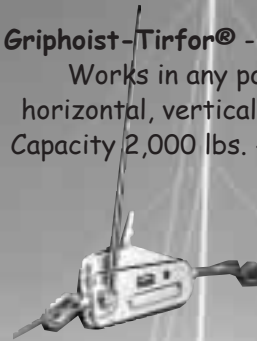

- Lifts
- Lowers
- Pulls
- Tensions



Super Pull-All® a remarkable
small-sized lightweight hoist.
Capacity 1,500 lbs.



GRIPHOIST® Division
CALL: (800) 421-0246
or (626) 937-6727 West Coast Branch
or FAX: (781) 828-3642
110 Shawmut Road, PO Box 188, Canton, MA 02021
e-mail: griphoist@worldnet.att.net

**Power when the sun
goes down...**

WINDSEEKER

12 years of
proven technology

Rated 500 Watts
Only 22 lbs. (10 kg)
Rotor Dia. 60" (1.5 m)
2 Year Warranty
Internally Regulated
High Wind Applications

Southwest Windpower
2131 N. First Street
Flagstaff, AZ 86004
Ph (520) 779-9483 Ext 11
Fax (520) 779-1485
dept11@windenergy.com
www.windenergy.com

ELECTRIC VEHICLE

COMPONENTS, CONVERSION KITS, PUBLICATIONS, VIDEOS,
AND ENGINEERING DESIGN SERVICES FOR THE EV
HOBBYIST AND MANUFACTURER...All components selected
with safety and reliability foremost in mind....We stock and sell the
largest variety of the very best:

- ◆ ADVANCED DC Motors in 9 variations from 2 HP to 28.5 HP
- ◆ CURTIS-PMC Controllers, Throttle Potboxes, Footpedals
- ◆ ALBRIGHT ENG. Main & Reverse Contactors in 6 models
- ◆ GENERAL ELECTRIC & HEINEMANN Circuit Breakers
- ◆ BUSSMAN Safety Fuses from 200 to 800 amps
- ◆ DC-DC Converters from 48 to 200 V input
- ◆ K & W ENG. & BYCAN Battery Chargers from 48 to 144 V
- ◆ Full line of CURTIS, WESTBERG, & KTA Meters & Gauges
- ◆ DELTEC Meter Shunts from 50 to 1000 A
- ◆ EVCC Adapter Plates, Couplings, Clamps, & Brackets
- ◆ PRESTOFLEX Welding Cable, MAGNA Lugs, Assy. Tools
- ◆ CONVERSION KITS for vehicles from 300 to 5000 lbs.
- ◆ Complete ELECTRATHON Drive & Instrumentation Pkg.
- ◆ 4 Complete GO KART kits...for up to 90 mph..

KTA SERVICES INC.

COMPONENTS & PUBLICATIONS CATALOG.....\$5.00
Electric Vehicle components and systems since 1984

944 West 21st Street - Upland, CA 91784 USA
Tel: (909) 949-7914 - FAX: (909) 949-7916
Web: www.kta-ev.com

Contact us
for volume discounts

SunLine Solar

Starting at **\$29.95**

Phone 1-800-886-4762 • Fax 717-351-0383

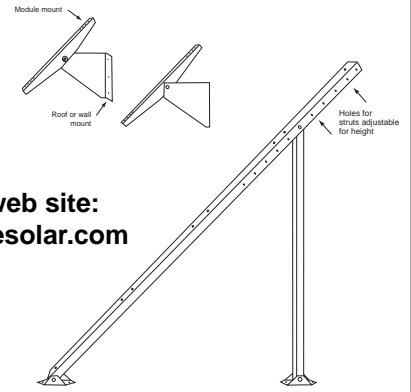
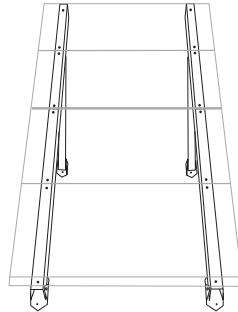
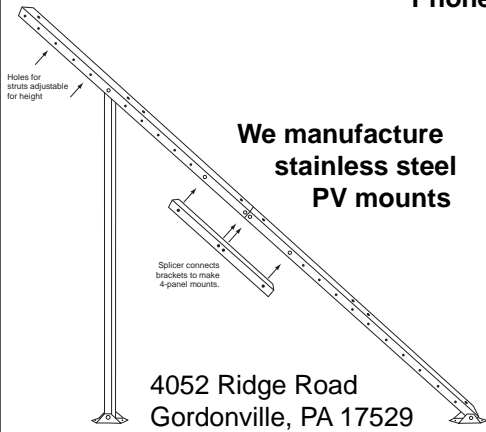

Visit our web site:
www.sunlinesolar.com

Harris Hydroelectric Hydro-Power for Home Use

Works with heads as low as 10 feet • Price starts at \$750

New Features:

- 17 bucket reshaped Pelton wheel
- Powder coated castings
- More efficient stator in high output models

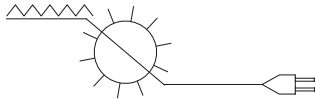

632 Swanton Road
Davenport, CA 95017
831-425-7652

*"The best Alternator-based MicroHydro generator I've ever seen."
Bob-O Schultze, Hydroelectric Editor, Home Power Magazine*

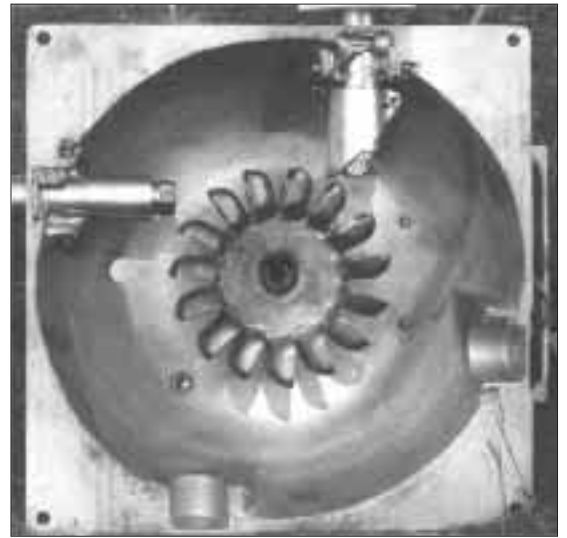

Super Efficient • Chest Style • Solar Powerable **Refrigerators & Freezers**

2 to 8 cubic feet inside volumes.
All units run on 12 & 24 Volts DC.

LOW KEEP REFRIGERATION

Web & International:

RICHARD

POB 409, Fennville, MI 49408
Phone: 616-236-6197
www.datawise.net/~lowkeep

US Sales:

DAN

24651 Second Ave.,
Otsego, MI 49078
Phone: 616-692-3015

Let Us Build One For You!

EPOWER® Charger / Booster



Prices start at **\$599.95**

- 12V-50, 100, 200 Amp
- 24V-25, 50, 100 Amp
- 38-64 lbs.
- Overload Protection
- Regulated Output
- Safety On/Off Switch
- Extended run LP option available—some models
- OHV engine option available—some models
- We also make a high quality OHV, all copper winding, brushless, 3KW AC generator, 120V or 120/240V

EPOWER
1346 W- 400S, Albion, IN 46701
Phone 219-636-2099
www.epowerchargerboosters.com



Don Loweberg

©1999 Don Loweberg

PV as Commodity

Several years ago, a colleague stated that PV modules were a commodity item. He implied that not much profit could be made on them. I didn't think about that too much at the time, but the comment stuck in my mind. Today I better understand what he was saying.

Webster's definition of commodity is "basic items or staple products." Some examples might be #2 Russet potatoes, pork bellies, electricity from the grid, steel, and lumber. Characteristically, they all have low profit margins.

PV modules are also staples. In many ways it is difficult to distinguish one module from another. Warranties are very similar. Electrons are electrons; they are indistinguishable from one another. Because of the generic nature of module performance, price per watt tends to be very tightly clustered and is primarily based on the purchased volume. Without major functional distinctions between various brands of PVs, marketing efforts are forced to focus on marginal distinctions such as "low light performance" or "shade tolerance." PV modules fit the definition of a commodity.

Are PV Systems a Commodity?

But PV modules are almost never useful by themselves. Modules require other components—racks, batteries, charge controllers, inverters, etc.—to make a functioning system. Though the balance-of-system components are also often marketed like commodities,

the system itself is not a commodity. To function properly, the system must be properly designed, installed, and provided with after-sale support.

Maybe someday PV systems will become commodities. There is a general trend in product evolution for all manufactured goods to end up as commodities. Many of my corporate friends and colleagues act as if the industry has already arrived at that point. That thinking is evident in the various "power in a box" products and the marketing efforts to sell them. But I, along with many other established dealer-installers, think otherwise.

A Common Misconception

Often customers see PV systems as commodities too. How many times have I taken calls asking for pricing on "solar units"? Yet this is understandable because grid electricity is a commodity, and it's easy to confuse the generating system with its product. Discount component marketers in this magazine and on the Internet routinely market kit systems as commodities. They suggest that with the assistance of "our knowledgeable sales staff, it is easy to design and install your own system and save big money."

Of course, some people do have sufficient electrical background and don't have problems, but many people get in over their heads. Judging by the number of calls we get each week for help, this problem is getting worse. When someone buys their gear at extreme discount and then calls a full service dealer for installation or troubleshooting assistance, the response is sometimes a bit short.

Something for Everyone

Clearly the PV market is differentiating. On one hand, we have the extreme discount outfits that offer pricing near wholesale but offer little else. In contrast are the companies that offer service along with hardware. A full service dealer typically will offer design, documentation (schematic drawings), load audits, energy efficiency information and products, installation, and—perhaps most important—service and maintenance after the sale.

Service and information come at a cost. That cost generally is imbedded in a higher markup. Keep in mind, though, that the total cost for the whole project may actually be less when working with a professional. Costs generated by mistakes like misconfiguration, undersized wires, and poor component selection will quickly exceed the ten percent savings you'll get shopping at parts marts.

Another trend developing is the complete unbundling of hardware from service and design. It is possible to find companies that offer design but do not actually sell any

hardware. These companies will design and spec out a system on a consultation basis, and send the customer out to shop for the equipment and find an installer.

So the PV customer today has many choices. This is good—it's a sign that the PV market is growing. But with the expanded number of choices in the marketplace, customers must be aware of what their needs are and have quality sources of information. Providing that information is one of the very important missions of *Home Power* magazine. With information, customers can choose a provider who matches their needs. And as always, caveat emptor!

Building Bridges

Independent Power Providers (IPP) formed five years ago to give voice to the independent installing dealers and their customers. At that time, there was a general industry-wide belief that regulated utilities were the "natural" agency to expand the market for photovoltaics. IPP members very much disagreed with that model, believing that the future of PV was with end-user applications. We were somewhat isolated from the position of most solar energy trade organizations and environmentalists and formed IPP as a forum for our vision.

As events have unfolded, our vision has turned out to be the correct one. Most new renewable generation will be distributed, not centralized. Throughout this transition of understanding, IPP maintained a working relationship with many groups in the renewables community. Many IPP companies, including our own (Offline), maintained membership in other solar trade groups.

Recently the California Solar Energy Industries Association (CALSEIA) appointed me to be a member of their board of directors. Given the positive working relationship IPP and I have had over the last few years with this group, both in California and elsewhere, I think this is an opportunity worth pursuing. With the convergence of understanding that has occurred in the renewables industry, this can be a very productive relationship. IPP will, of course, continue to be a completely independent organization.

PV in the Rest of the World

Many readers may be aware that PV usage outside the United States exceeds our domestic use by about two to one. Three major markets account for this: vigorous subsidy programs promoting grid-connected PV in Europe and Japan, and rapidly expanding off-grid usage in the developing world. An excellent source of information on PV and other renewables outside the US is *Renewable Energy World*, published by James & James.

The latest issue (July 1999) has an article by Lalith Gunaratne titled *Solar Energy Business in the Developing World*. It details PV electrification programs in Sri Lanka. The author makes a strong case for developing local infrastructure based on a "new kind of company," emphasizing the importance of the front-line people. Without a new business structure, the author asserts, sustainable development will not occur. That point resonated with me since this is a fundamental premise of IPP.

The article set my mind to thinking. For years it's been presumed that PV development models for the developing world and the West are different. Could this be a mistake? For instance: the U.S. grid-connected "green market" seems to be developing slowly, yet there is a surge in demand for grid backup systems.

Technically, grid backup systems are "off-grid systems." What's the difference between a farmer in Fresno, California with wires connected to his house but no power, and a farmer in Sri Lanka with no wires connected to his house and no power? In both cases, they may be willing to buy what they don't have if they perceive a need, even if it is expensive.

Access

Author: Don Lowebug, IPP, PO Box 231, North Fork, CA 93643 • 559-877-7080 • Fax: 559-877-2980
i2p@aol.com • www.homepower.com/ipp

California Solar Energy Industries Association (CALSEIA), PO Box 782, Rio Vista, CA 94571
800-225-7799 or 949-837-7430 • Fax: 949-586-2357
lanelson@worldnet.att.net • www.calseia.org

James & James (Science Publishers) Ltd., 35-37 William Rd., London NW1 3ER, UK • +44 171 387 8558
Fax: +44 171 387 8998 • rew@jxj.com
james@jxj.com • www.jxj.com



PeaPac Portable Power!

AC and DC power whenever and wherever you need it.

Versatile "power-in-a-box" can be used for emergency, backup, or full time power in your home, boat, camp, RV, car, construction site...

Take it with you! Safe and easy to use with optional built-in AC or solar charge inputs,

PeaPacs are ready to work for you!

200 or 1300 watts of power.

Prices start at \$299 (less battery).

~ Spectacle Technology ~

"The company with vision"

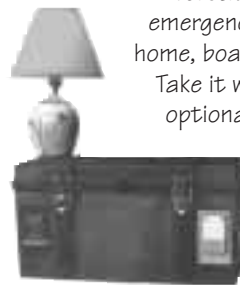

P.O.Box 114, E. Calais, VT 05650 • 802-456-7097
www.spectacletech.com/ email: info@spectacletech.com

SOLAR WEBB, INC.

"Fueling Your Future"

Southern California

SOLAR WEBB, Inc.



Beat the Heat with our Attic Vent Fan Kits,
Using solar power to keep your house *Happy!*
ONLY \$244.00 for equipment!!!

Order Line: **888-786-9322**

Your Authorized Trace Dealer



Visit our website at: <http://www.solarwebb.com>

ETA ENGINEERING

MANUFACTURER OF RE SYSTEM PRODUCTS

44 AMP PV BATTERY CHARGE REGULATOR (PBR SERIES)



- 88 AMP SURGE RATING FOR 20 SECONDS
- TEMPERATURE COMPENSATED CHARGING
- PATENTED PARALLEL SWITCHING SHUNT
- PULSE WIDTH MODULATION
- 12 & 24 VOLT MODELS
- 5 YEAR WARRANTY

BATTERY CAPACITY METER



- LED SCALE DISPLAYS BATTERY BANK VOLTAGE & CAPACITY IN 10% INCREMENTS
- LEDs FOR FLOAT, EQUALIZE, & LOW VOLTAGE
- SOLID-STATE ELECTRONICS
- 12, 24, 36, & 48 VOLT MODELS
- 60 INCH #22 AWG CABLE INCLUDED

CONTACT YOUR DEALER FOR AVAILABILITY

ETA Engineering, Inc.
2010 E. University Dr.
Suite #11
Tempe, AZ 85281
Toll Free: (877) 964-4188
www.ETAengineering.com
ETAEng@aol.com



AUTHORIZED DISTRIBUTOR OF:

INVERTERS / CHARGERS



Vari-Fan

The most versatile
DC-powered ceiling fan
ever offered.

See more at our Web site:

www.fanworks.com

e-mail: **info@fanworks.com**

or write:

RCH Fan Works

2173 Rocky Creek Rd.

Colville, WA, USA 99114

Fax (509) 684-5199

Dealer Inquiries 1-800-529-6306

Zomeworks

b/w on negative

3.4 wide

4.5 high

AUTOMAGIC BATTERY WATERING



WE MAKE WATER FROM YOUR GAS

Hydrogen and oxygen battery gas catalytically recombined into pure water and returned to each battery cell. Keeps battery topped off for extended periods of time and reduces maintenance costs. Explosive hydrogen gas is virtually eliminated from the battery area. Corrosive spray and fumes are contained and washed back into each battery cell. Electrolyte kept strong longer, extending the useful power and life of the battery. HYDROCAP Vents simply replace the battery's caps. Battery maintenance is greatly reduced. Write or call for more information.



Things that Work!

Hydrocap
GRANITE BATTERY CAPS

305-696-2504
975 NW 95 St.
Miami, FL 33150

Snorkel Stove

b/w on negative

3.5 wide
4.5 high

NEW ENGLAND SOLAR ELECTRIC, INC.

3 South Worthington Road, PO Box 435
Worthington, MA 01098
1-800-914-4131



This is the most popular book for PV remote homes. It is written and published by New England Solar Electric Inc.

"Best all around book on wiring your PV system."

Real Goods Sourcebook

"Our favorite book for Do-It-Yourselfers."

Windy Dankoff, Dankoff Solar Products

\$16.95 plus \$3 PPS
(includes our \$3 catalog)

"This should become the bible for alternative energy users."

Ken Cox, Trace Inverters

Send \$3 for our 80 page catalog and product guide

Servel/Dometic Gas Refrigerators. Trace Inverters. Trojan Batteries. Siemens & Solarex PV modules, Osram Bulbs. Thinlite Fixtures. Aquastar Hot Water Heaters. AIR 403 Wind Generators

*Best book, most user friendly catalog,
& best kits in the business.*

You can turn water into juice using the **STREAM ENGINE**

- Operates at heads of 10 feet & up
- Adjustable for maximum power
- Multiple output voltages
- Output over 1KW
- Easy installation



Epoxy Encapsulated Alternator

Waterproof, Water Cooled,
Neodymium Permanent
Magnets, Brushless,
Reconnectable Windings

Precision Cast Bronze

Turgo Wheel
High Efficiency, High Capacity

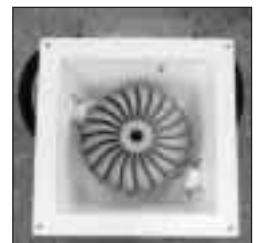

Also Available:

Hydro components including
turgo & pelton runners, system
design, and tech support

\$1695

"This is a very cool machine. It represents a major breakthrough in microhydro design." -Bob-O Schultze, Home Power #67

Energy Systems & Design

P.O. Box 4557, Sussex, NB, E4E 5L7, Canada
Tel: (506) 433-3151 • Fax: (506) 433-6151
website: www.microhydropower.com
email: hydropow@nbn.net.nb.ca



Things that Work!

PV Grounding on a Single Dwelling

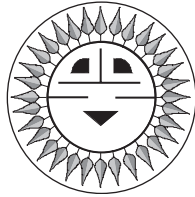

John Wiles

Sponsored by the Photovoltaic Systems Assistance Center,
Sandia National Laboratories

Properly grounding a PV system is one of the more complex tasks in meeting the requirements of the *National Electrical Code (NEC)*. In the *Code Corner* column in *HP72*, I covered the general requirements and definitions related to grounding. In this *Code Corner*, I'll present specific details for grounding a PV system where the PV modules are mounted on the roof of a dwelling and all equipment is contained in the same building.

Stand-Alone Systems

In a stand-alone PV system, there are no power connections to any electric utility. There is an energy storage system (batteries) and possibly a backup generator. Each of the grounding requirements for this type of system will be covered below (I'm assuming that the PV system is a grounded system—see *HP72*).

Section 690-5 of the *NEC* also requires that systems with PV modules mounted on the roof of a dwelling have ground-fault protection equipment. The Trace GFP-1 through GFP-4 are ground-fault protection devices that meet the requirements. Other equipment may also be available in the future. Some assembled power centers and panels include the ground-fault equipment. It is assumed, for purposes of discussing grounding, that the ground-fault protection equipment is being used and has been installed in accordance with the manufacturer's instructions.

Module Frame Grounding

The frames of listed PV modules will have a designated point to attach the equipment-grounding conductor. This is usually a special screw or lug marked with a green crosshatched arrow (the standard symbol for grounding). The equipment-grounding conductor for the circuit or circuits from the modules should be sized according to Table 250-122 in the 1999 *NEC* (Table

250-95 in the 1996 *NEC*). This table requires that the equipment-grounding conductor be sized according to the rating of the overcurrent device protecting the circuit. See the table below for some typical values from the *NEC* table.

The equipment-grounding conductor can be a bare wire, and usually will be if exposed in the outdoor environment. If it is insulated, it must have green insulation, but it is difficult to find wire with green insulation in a sunlight-resistant, outdoor-rated conductor. When the equipment-grounding conductor is routed in conduit, then green-insulated conductors like THHN/THWN-2 are commonly available. Bare conductors are also allowed in conduit.

The *NEC* allows the equipment-grounding conductor for DC circuits to be routed separately from the current-carrying conductors. A typical installation might look like Figure 1 and have the following parameters (these numbers are given as examples only). The circuit breaker or circuit breakers protecting the main circuits coming from the roof and located in the power center or main PV disconnect are 30–60 amps. A #10 AWG (5 mm²) bare conductor is connected from module to module using the equipment-grounding screw on each module. This conductor is then routed along the outside of the conduit to the PV combining box (if any) and then to the power center or other disconnecting means, where it is connected to an equipment-grounding screw.

If non-metallic sheathed UF or NM cable is used from the roof to the power center, the usual equipment-grounding conductor in this cable can be used. The equipment-grounding conductor from the modules may also be routed inside the conduit when an entry point to the conduit is available.

The equipment-grounding conductor from module to module should also be connected to the module mounting rack or frame. If there are smaller fuses or circuit breakers (4–20 amps) in the PV combiner box (used to protect the modules), it is possible to use smaller equipment-grounding conductors from the box to the module frames (as noted in the table).

Equipment Grounding Conductor Sizes

Overcurrent Device Amperage	AWG	mm ²
15	14	2
20	12	3
30	10	5
30	10	5
40	10	5
60	10	5
100	8	8

Figure 1: PV Module Equipment-Grounding Conductors for a Roof-Mounted PV Array

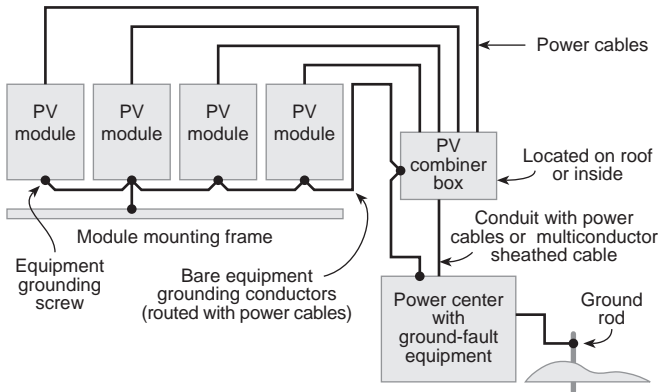

However, smaller conductors are more prone to physical damage and are required to have protection. I suggest #10 AWG (5 mm²) as the smallest gauge of bare conductor for equipment-grounding conductors for the exposed wiring to the PV modules. Even this size conductor must be protected from physical damage. In high lightning areas, other equipment-grounding techniques might be used.

Grounding of Other Equipment

In other circuits in the system, the equipment-grounding conductor must be sized according to the tables in the *NEC* (listed above). It must be based on the size of the overcurrent device protecting that circuit. For example, let's say the circuit breaker between the inverter and the battery is a 250 amp unit. The equipment-grounding conductor between the inverter and the circuit breaker enclosure, and also to any metal battery box or rack, should be a #4 AWG (21 mm²) conductor. A 400 amp fuse in this circuit would dictate a #3 AWG (27 mm²) equipment-grounding conductor.

The Grounding System

In any dwelling, the *NEC* requires any metal water piping and any metal gas piping to be tied to a grounding electrode. In most places, the grounding electrode is an eight foot (2.4 m) plated rod or pipe driven into the earth. The DC electrical system (and the AC electrical system connected to an inverter) must be connected to this grounding electrode system.

The actual connections from the ground rod to the DC and AC electrical system will vary from system to system. In most cases, all of the equipment-grounding conductors for the system will terminate at an equipment-grounding block and the grounding-electrode conductor will connect to this block. From that point, the grounding-electrode conductor will run to the ground rod where a listed clamp is used to connect it to the ground rod.

If there is only one conductor connected to the DC ground rod, then it may be as small as #6 AWG (13 mm²). If there are multiple conductors tied to the ground rod, then the DC grounding electrode conductor must be as large as the largest conductor in the system, which is usually a #2/0–4/0 AWG (67–107 mm²) battery cable.

The design of the ground-fault device will determine how the bond is made between the grounded current-carrying conductor and the grounding block. In most power centers and power panels, this bond is made at the factory.

AC System Grounding

In most stand-alone systems, the inverter includes an internal transformer that separates the DC system grounding from the AC system grounding. There will be an AC output from the inverter connected to an AC load center for the dwelling. There should be an equipment-grounding conductor connected between the inverter and the AC load center. This conductor will be sized based on the rating of the overcurrent device at the output of the inverter.

For example, the *NEC* requires a #10 AWG (5 mm²) equipment-grounding conductor when a 60 amp overcurrent device protects the circuit. In most cases, the AC load center will have a separate grounding electrode conductor and a ground rod. The equipment-grounding conductor between the inverter and the AC load center serves to bond the two ground rods together.

If the DC power center and the AC load center are near each other, it may be possible to use a single ground rod for both AC and DC grounding. In this case, there will be more than one grounding-electrode conductor connected to the ground rod. So the DC grounding-electrode conductor will have to be sized as large as the largest conductor in the DC system (usually the battery-to-inverter cable).

The size of the AC grounding electrode conductor will depend on the size of the conductor feeding the AC load center. A #6 AWG (13 mm²) conductor will serve as an AC grounding-electrode conductor for main AC power conductors up to and including #1/0 AWG (53 mm²) copper. A #4 AWG (21 mm²) grounding-electrode conductor will serve with power conductors up to #3/0 AWG (27 mm²). See 1999 *NEC* Table 250-66 (250-94 in the 1996 *NEC*) for additional values.

Systems with a generator also require an equipment-grounding conductor between the generator and the inverter. This conductor will be sized based on the rating of the overcurrent device at the generator. A 60

Figure 2: AC Grounding System

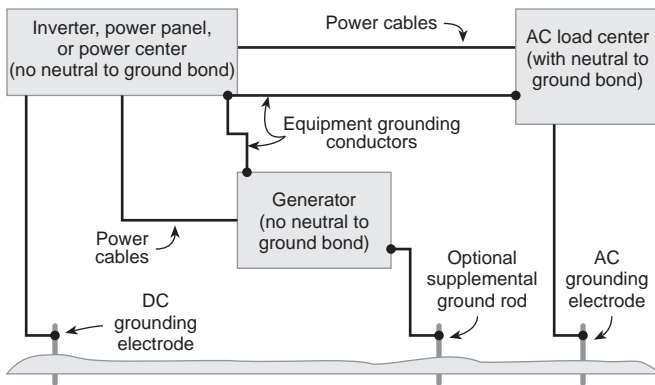

amp circuit will require a #10 AWG (5 mm²) equipment-grounding conductor. A 100 amp circuit requires a #8 AWG (8 mm²) equipment-grounding conductor. In some locations, a supplemental ground rod may be required for the generator and should be connected only to the generator frame (equipment-grounding system).

Neutral-to-Ground Bond

In the AC system, there should only be one connection between the AC neutral and the grounding system. This will normally be in the AC load center for the dwelling. Generator, inverter, power center, and power panel schematics, as well as manufacturer's literature, should be closely examined to determine that there are no neutral-to-ground connections in these devices.

The *NEC* requires the removal of additional (more than one) bonds that cause normal currents to flow in the equipment-grounding conductors. Qualified technicians should remove any unwanted bonding between the grounded conductor (usually the neutral) and ground. Figure 2 shows typical AC equipment-grounding connections and the grounding system.

In future *Code Corner* columns, grounding for other PV configurations will be addressed. These systems will include utility-interactive systems and systems where the PV array is ground-mounted away from the point of use.

The 2002 Code Cycle

Although the 1999 *National Electrical Code (NEC)* just became effective on January first of this year, complete and well-substantiated proposals for changes to the 2002 *NEC* are due to the National Fire Protection Association (NFPA) no later than 5 PM EST on Friday, November 5, 1999. This gives those individuals wishing to propose changes for the 2002 *NEC* less than three months to write and submit the proposed changes and the required substantiations. The correct form for submittal to the NFPA can be found in the back of the

1999 *NEC*. Electronic submissions may also be made. Contact NFPA for details.

Ward Bower at Sandia National Laboratories and a team of people from the PV industry (including utilities, vendors, installers, and users) will be working via email to write and substantiate proposals for the 2002 Code. A meeting is scheduled for October 7, 1999 in Tucson, Arizona. Contact Ward directly if you wish to participate in this activity. You can also send your ideas to me for entry into the system, if you provide, or we can develop, the necessary substantiation. Send your email address if you would like to receive information on the team's email deliberations on the 2002 *NEC*. For now, we have the following items under consideration:

- Figure 690-1: Label the energy storage.
- Section 690-5: Reword for clarity; possibly remove entire article.
- Section 690-6: Review ground-fault equipment requirements for AC PV modules.
- Section 690-7: Consider expanding for thin-film devices.
- Section 690-8: Add requirements or exceptions for low-power inverters.
- Section 690-45: Revise for PV source and output circuits.
- Section 690-8(b): Possible exception for current-limited devices.
- Section 690-31(b): Modify for clarity and technical correctness.
- Section 690-45: Reword or delete.
- Section 690-54: Reword for consistency.
- Section 690-64: Revise for utility-interactive systems in commercial buildings.
- Section 690-64: Remove restrictions on back-fed circuit breakers.
- Section H: Add prohibition on flooded, steel-cased batteries in systems operating over 50 volts.
- Section H: Consider a provision for ungrounding battery banks over 48 volts nominal (24 cells) for servicing.
- Section H: Specify labels for the battery system to include configuration, grounding, and polarity.

What are your ideas? Where have you had trouble with the code or with language not clear to electrical inspectors? What can be added or changed to make your job easier?

Please keep in mind that the *NEC* is a consensus document. If you participate with an input directly to NFPA, you will get a copy of all of the 2002 *NEC* proposals. You will also have a chance to comment on any of them and will get a copy of all of the comments on all of the proposals for the 2002 *NEC*. The proposal and comment documents weigh about eight pounds (3.6 kg) each and they include the deliberations, comments, and actions taken by each of the code making panels.

Questions or Comments?

If you have questions about the *NEC* or the implementation of PV systems following its requirements, feel free to call, fax, email, or write me. Sandia National Laboratories sponsors my activities in this area as a support function to the PV Industry. This work was supported by the United States Department of Energy under Contract DE-AC04-94AL8500. Sandia is a multi-program laboratory operated by Sandia Corporation, a Lockheed Martin Company, for the United States Department of Energy.

Access

Author: John C. Wiles, Southwest Technology Development Institute, New Mexico State University,

Box 30,001/ MSC 3 SOLAR, Las Cruces, NM 88003
505-646-6105 • Fax: 505-646-3841 • jwiles@nmsu.edu

Sponsor: Sandia National Laboratories, Ward Bower,
Department 6218, PO Box 5800 MS 0753,
Albuquerque, NM 87185-0753 • 505-844-5206
Fax: 505-844-6541 • wibower@sandia.gov

National Electrical Code® and *NEC®* are registered trademarks of the National Fire Protection Association. The 1999 *NEC* and the *NEC Handbook* are available from the NFPA, 11 Tracy Drive, Avon, MA 02322
800-344-3555 or 508-895-8300 • Fax: 800-593-6372 or 508-895-8301 • custserv@nfpa.org • www.nfpa.org

Soares Book on Grounding, US\$38.95 postpaid in the U.S. from International Association of Electrical Inspectors, 901 Waterfall Way, Suite 602, Richardson, TX 75080-7702 • 800-786-4234 or 972-235-1455
Fax: 972-235-6858 • iaiei@compuserve.com
www.iaiei.com

Wiles, J. C. and Bower, W. I., *Analysis of Grounded and Ungrounded Photovoltaic Power Systems*, First World Conference on Photovoltaic Energy Conversion, Hawaii, 1994





The Dual Axis Tracking Advantage
**as compared to a fixed mount tilted at latitude*

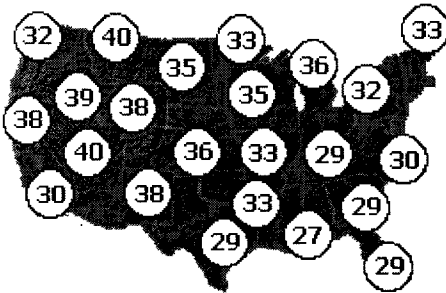

Percent Annual Power Increase
More Power...Less Money

ARRAY TECHNOLOGIES, INC. WWW.WATTSUN.COM
3402 STANFORD NE, ALBUQUERQUE, NM 87107
TEL: (505) 881-7567 FAX: (505) 881-7572

New Product Announcement

Pure Sine 300 Sine Wave Inverter



300 Watts of continuous AC power
Fully-regulated 115 VAC sine wave output

Clean output quality for:
computers
audio equipment
sensitive electronics

For use with:
12, 24 or 32 V battery systems
as full-time or back-up power

SOLTEK supplies solar systems and products for:

- cottages
- RVs
- boats
- custom installations

SOLTEK
SOLAR ENERGY LTD.
Independent energy solutions since 1986

Canadian Toll Free: 1-800-667-5327

Siemens Solar PowerPro PARTNER

#2 - 745 Vanalman Avenue
Victoria, B.C. V8Z 3B6
Website: www.soltek.ca
E-mail: soltek@soltek.ca

US distributor & dealer inquires welcome **Call: 1-250-727-7720**
Fax: 1-250-727-2135



SOLAR CONVERTERS INC.

We manufacture power supplies for the renewable energy industry.

New Products

- 60 amp. Power Tracker™ charge controller with MPPT and voltage conversions
- Constant Voltage Pump Driver with integral LVD and Float Switch Control
- Voltage Controlled Switch - a simple relay switch for many uses

Triple your power savings!

- Use our products with maximum power point tracking to get all the power that you paid for. *Typically you only get 53 watts of performance from a 75 watt panel.*
- Our proven technology is combined with voltage conversions, which allows you to connect to high voltage panels using smaller wire, again saving cost.
- Use the cost effective high voltage panels and really save on your system.

Also, our usual large selection of LCB's, Cathodic Protection Controllers, DC to DC Converters and more.

Highly efficient, reliable, low cost. Call your local dealer!

SOLAR CONVERTERS INC.

C1-199 Victoria Road South Guelph, Ontario N1E 6V1 Canada

Ph. 519-824-5272 Fax. 519-823-0325

Email: info@solarconverters.com Web: www.solarconverters.com

Palouse Wind & Water

1011 Rothwell Road, Viola ID 83872

208-883-3676 or fax 208-883-3298

pwindh2o@moscow.com

1 Completely Remanufactured 10KW-12.5KW to 15KW Jacobs Wind Turbine. Complete 90' tower or 70° Rhone tower Hinged base, UTILITY INTERCONNECT model, can be modified for OFF Grid, UTILITY INVERTER + CHOKE, Onan 20 KW Alt, Finned Gear Head – No Blades – 6 mo Warranty—Installation By Contract. Qualifies for Fed TAX Incentives and does Qualify for Calif Buy Back Program.

\$11,000

Also (1) 40 VDC 2500 Watt Jacobs Short Case

Call For Pricing, with tower

Plus TAX, Shipping, and extra for OFF Grid

3S30 Three Stage PWM Charge Controller

Full featured 3 stage 30 amp PWM Charge Controller for best battery performance and longevity.

Complete digital metering. Oversized #6 wire connectors.

New DSC circuitry for cool efficient operation. Safe for all batteries. Available in 12 and 24 volt models. Easy installation. Available world wide.



B. Z. Products, Inc.

7614 Marion Ct., St. Louis, MO 63143, USA

tel: 314-644-2490, fax: 314-644-6121

email: bzp@inlink.com

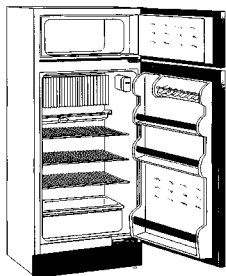

Propane Refrigerator DPR2260

\$995.00

Plus Shipping

Danby®

"Good things come in small packages"

- 7.8 cu. ft. Capacity Refrigerator.
- Reversible Door Hinges.
- Door Liner has large, functional divisions, plus a molded Egg Rack.
- Tall Upper Shelf accommodates 1 & 2 gal Jugs.
- 3 Easy-glide Shelves and a Large Crisper.
- Battery Powered Refrigerator Light.
- Automatic Lighter (piezo-electric)
- Automatic Safety Valve.
- European Style Door with Recessed Handles.
- Refrigerator is AGA & CGA Approved.
- No Electricity Needed.

Dealer Inquiries Invited

(800) GO-SOLAR (467-6527) sales@energyoutfitters.com
136 S. Redwood Hwy, POB 1888, Cave Junction, OR 97523
Web Page: http://www.energyoutfitters.com



SolarRoofs.com

Complete Solar Water Heaters starting at \$895!

FIREBALL 2001

- Y2K Compliant
- PV Options
- Patented Design
- Dealer Inquiries Welcome



Check out these Exciting, Very Easy to Install, & Affordable Systems!

We are Web based: www.solarroofs.com

SolarRoofs.com, Carmichael, CA • (916) 481-7200

AC/DC Inverters, Solar Electric Modules
 Batteries, Charge Controllers
 DC/Propane Refrig, Track Rack
 Water Pumps, DC Lights, DC Appliances

1-888-SOLARNOW
Toll Free

HORIZON INDUSTRIES

*We Sell The Best
& Service The Rest*

Mention This Ad & Receive A Free 100 Page Catalog
 2120 W Mission Rd (# L), Escondido, CA 92029
(760) 480-0403
www.horizonsolar.com







Solar Pathfinder

The Best Tool For Solar Site Analysis

We will be on the road during July & August. Please call & leave a message & we'll get back to you ASAP.

* **Pathfinder with metal case & tripod \$210, Handheld \$135 (+ shipping)**

196 Moore Road, Dept. HP
 Iron City, TN 38463-5332
 Phone & Fax 931-724-6528





PLANET DC

Now! RParts carries Planet DC refrigerators and freezers. We have everything to meet all your refrigeration needs at RPrices. Guaranteed lowest.

Call 800-720-3907 for a brochure

RPARTS
 REFRIGERATION PARTS SOLUTION
 P.O. BOX 5633 BERKELEY, CA 94705-0633
 (800) 720-3907 (510) 436-3962 FAX (510) 533-5605
refparts@refparts.com www.rparts.com

Have a South Window?



THE GREENSHELF™
A Solar Gardening Shelf!

Put that sunshine to work for you growing food and starting seedlings with **THE GREENSHELF™**.
 Indispensable year round for herbs, salad greens, succession plantings, house plants and lots more!
 Works great in a greenhouse, too.

Call **1-800-400-2684** for free brochure or see online at **www.greenshelf.com**
 5408 County Road 250 • Durango, CO 81301

The Solar Panel Sale of the Century!

Brand New - First Quality - At an unprecedented \$4.25 a Watt

Photowatt 75 Watts, Only \$318.00!
Photowatt 100 Watts, Only \$425.00!

This is a limited time introductory offer! First come, first served!

The name Photowatt is synonymous with unmatched quality!
 These are heavy duty industrial grade panels utilizing the latest 2mm polycrystalline technology.

SOLAR ON SALE

Toll free 1-888-64-SOLAR (76527)
<http://www.solaronsale.com>



Home & Heart



Kathleen Jarschke-Schultze

©1999 Kathleen Jarschke-Schultze

This has been the Season of the Bees for me. If I am at home, I am constantly looking in on my two hives and discussing bee-havior with my friend, Mona. She started one hive this spring when I started two. We are both novices, and we have been lugeing the learning curve together from the beginning.

Location, Location, Location

Before I picked up my bees, I carefully chose the exact place for the hive stand. We have two 1,350 gallon black polyethylene water tanks up on the property line behind our house. I thought this would be the perfect place for the stand. It gets first sun in the morning and then has sun most of the day. I figured the water tanks would provide wind protection.

I was wrong. There was not enough wind protection. We had an unusually cold spring. Neither of my hives flourished. The bees would barely leave the hives. I put up a plywood wind break on one side of the water tanks. After that, the white hive (the one closest to the windbreak) became more active and took up more syrup from the feeder. The Celtic hive (it has a Celtic knot painted on the hive body) never really became as active as the white hive.

After a time, I checked for newly laid brood and found it in both hives. You can rarely actually find a queen in the hive, so the brood is the indicator of a working queen. I did not have the hives open for long because of the cold weather.

The brood must be kept at 92°F (33°C) in order to mature. I left the hives alone except for feeding them for a long time. The Celtic hive remained slow and not very active. The white hive was more lively, with bees constantly coming and going from its entrance.

Dethroned

I finally had Bob-O go up with me one warm day and

really check out the hives. We found brood in both hives and a lot of drones (male bees). In the Celtic hive, we found a queen cell, but it was empty.

The hive will produce more drones to help keep the hive warm. They are larger than the workers and just hang around the hive generating heat. Their only other function is to fertilize the queen on her one mating flight. When the outside temperature gets warmer and the hive heats up, the drones are cast out to die.

A hive will only build a queen cell if it needs a queen. This might be to split a hive that has gotten too large for its home. In that case, approximately half of the bees leave with the old queen and leave the new queen in the old hive. The other reason for hatching a queen is because there is no queen in the hive (queenlessness). In that case, laying workers appear who will lay eggs and try to raise brood. Their attempts will ultimately be unsuccessful. The only type of bee a laying worker can produce is a drone. I suspected the Celtic hive of queenlessness.

John, the Bee Guy

My friend Dave has a friend who keeps bees locally. He gave me the name and a phone number to call if I had bee questions. The only caveat was that I was not to consider this man an expert. I immediately dubbed the friend "John, the bee guy." I promised myself I would only call him if I was totally stumped. I called him.

John, the bee guy, has several hives and has been keeping bees for four years. He may not be an expert, but he's got it all over me for experience. When I called, I described what I found and what I thought. I asked if he had ever experienced queenlessness. Once he thought he had, but then the hive recovered and was able to survive the winter. He advised me to let the hive run its course, be that survive or perish. I resigned myself to just that.

Bee Tree

We had gotten up at 5 AM in order to be on the road to the Oregon Country Fair by 6. At ten minutes of 6, I realized I needed to fill the feeders on the hives. I started up the hill to the hives with George, a visiting friend who used to keep bees. At the base of the path in the Asian Pear tree, there was a swarm of bees.

I went up the hill to fill the feeders and check the hives. George went back to tell Bob-O we wouldn't be on the road by 6. Since I didn't have an extra hive to put the swarm in, I decided to hive the swarm into the hive I suspected of queenlessness. George had hived swarms before and talked me through it step by step. I knocked the bulk of the swarm into a cardboard box by shaking the small tree sharply. Then I went on up the hill to the hive. I placed a single sheet of newspaper on

top of the hive body. I then put an upper entrance (Imrie shim) on top of that.

I placed a full sized super (bee box) on top of that, and then I was ready to pour the swarm in. After the major part of the swarm was in the top super, I replaced the frames and put the lid on. With the cardboard box and my bee brush, I gathered as many loose bees from the tree as I could. I added those to the hive. Then I left for a week.

The single sheet of newspaper was for separating the two sets of bees temporarily. By the time the bees had chewed through the paper, the old bees would have had time to accept the new queen. That was my theory and what did I have to lose anyway? I hived that swarm in twenty minutes start to finish.

Swarm Again

Bob-O called home while we were gone and Mona had found a swarm of bees in the peach tree across the path from the pear tree. She got the camera and took pictures for us. Soon after, they were gone.

That's okay with me. Now there is a swarm of wild bees out there somewhere. We need more wild bees. When I returned home from the fair, the newspaper I'd left had been eaten though, but the population of the hive seemed no greater than before I added the swarm. I now think that the swarm Mona found was the swarm I had hived, and that they rejected my hiving attempts.

Bee Patient

Neither of my hives are doing as well as Mona's. Her hive is in a protected area out of the wind, on the hillside. Hers is a healthy, thriving hive. Mine are struggling still. I put an old table top on the two hives to provide shade in the hot part of the day. I went though the hives and alternated frames full of honey with empty frames.

I removed the queen excluder on the white hive. A queen excluder is a metal screen that allows worker bees to pass through to the upper super and frames, but keeps the larger queen in the lower brood box. That way you don't have brood mixed in with the honey on the frames. Sometimes, especially in newly built comb, the new workers hatched are larger than subsequent workers and cannot easily pass through the excluder.

Bee Prepared

Here is what I have learned so far. Medicate your hives in the spring and fall. There are several preventative medications to be fed to your bees, but not during a nectar flow. John, the bee guy, clued me in on that one. Always have extra bottom boards and hive bodies with frames and covers ready to go in case a hive swarms. I thought I had at least one season before I would need

them. If I had had the equipment ready, I could have hived that swarm and put it in a better location right then. Wind—cold or warm—totally stresses a hive. Your hive location must have sun in winter and shade in summer.

I am rooting for these hives to survive. However at the same time I am planning a new location for my next hives and gathering more equipment now. I have learned that the hives can't be moved more than three feet after they are set up (unless they are moved more than three miles) or they will swarm back to the original location.

My experiences have not deterred me at all. I figure if these hives make it though the winter, they'll be ready to start growing early in the spring. I will be starting more hives in any case. This time I will know to place them in a better location. I am a bee wrangler.

Access

Kathleen Jarschke-Schultze is taking a class in Web publishing at her local college and planting lavender at her home in Northernmost California, c/o Home Power, PO Box 520, Ashland, OR 97520 • kathleen.jarschke-schultze@homepower.com



"SHINE"

D.O.B. 6/16/98
Long Wool, Nice,
Dual Tone Jumper

C.W. Ranch, ID-2
775-463-2705 • 10-2 pm

Do You Need Batteries?...

RAE Storage Battery Company

Since 1943... Quality & Service

Surrette Solar 1, 400 Series, Type CH 375 - L16

- 33.3% More Life Cycles
- Greater Reserve Capacity
- Expected Life of 10 Years
- Warranty 2 Years Unconditional
3 Years Prorated
- Available Wet & Dry Charged
- Engineered under careful guidelines
by Dave Surrette - Family owned
business Est. 1935



If you need Competitive Pricing
& Prompt Delivery call: 860-828-6007



Fax 860-828-4540
51 Deming Rd., POB 8005,
Berlin, CT 06037

Northwest Energy Storage is now wholesaling all Surrette Batteries west of the Mississippi. Call 800-718-8816

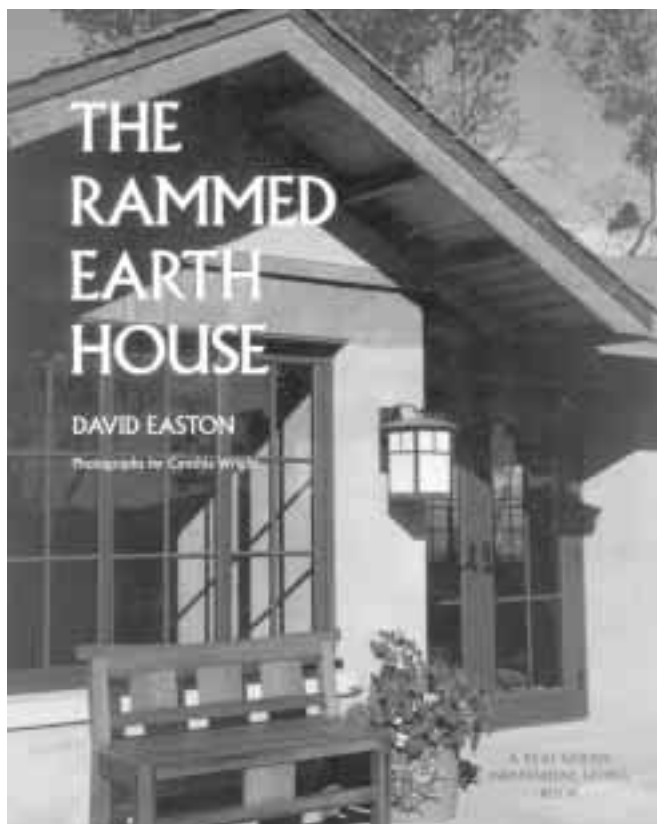

The Rammed Earth House

by David Easton

Reviewed by Richard Engel ©1999 Richard Engel

Ask renewable energy (RE) users what drives them to make their own power, and you'll get a broad range of answers: economics, environmental concerns, a desire to live independently. One motive shared by many RE folks is the desire to use resources available on site—be it sunshine, wind, or flowing water—rather than import their energy from far away.

Local Energy

Along with that imported energy may come imported costs, many of them hidden. These include energy for transporting materials from resource extraction sites to processing plants and then to the construction site, pollution, health impacts, and habitat destruction. Like RE, rammed earth construction avoids some imported costs and offers an opportunity for the builder to use on-site resources in the creation of a home.

David Easton's *The Rammed Earth House* provides an overview—and a lot of hands-on detail for those of us considering this green building technique, at once ancient and modern. The book is published by Chelsea Green, and is part of the Real Goods *Independent Living* book series.

Beginners Welcome

One thing I liked about this book right away is that it doesn't assume the reader has built a house before, even a conventional one. The author holds our hands through chapters on site selection and architectural planning, with a view that is broad enough to introduce the novice to these important pre-construction concepts.

It's only upon arriving at the sixth chapter, *The Essential Soil*, that we really begin to see what sets rammed earth apart from the "ordinary" lumber and sheetrock structures we've grown up with. Easton describes the ideal building soil and simple field tests for evaluating the soil on site. The best mix for rammed earth, Easton tells us, is 70 percent sand and 30 percent clay, although he assures us that a fairly wide range of soil types can be adapted for building earth walls.

I was surprised at how much of the book was dedicated to building the wooden forms for earthwall construction. But as in concrete work, these forms are essential. The real heart of the book is a discussion of the actual ramming of the earth. The author acknowledges that it's not for everyone, what with the "environment filled with the dust of soil and cement, the roar of diesel engines, and the staccato *thump thump thump* of backfill tampers."

He notes that the vast majority of rammed earth structures on the planet today did not avail themselves of such technological resources. He then explains that building rammed earth "the old way" with hand tools would incur unbearable labor costs for the modern commercial builder. An owner-builder with a lot of time on his or her hands or a lot of friends might make a go of hand-building, however.

All This and Photos Too

Easton also gives a lot of attention to the use of wall-topping bond beams and other devices for ensuring a building's seismic safety. This and other topics are well-presented, with abundant photos throughout the book. There is also a photo essay appendix that walks the reader through a rammed earth construction job from the ground up.

The book even includes a color photo section that's sure to get you dreaming of your own earthen home. And for the techies, there's an additional appendix that treats rammed earth construction from a quantitative engineering perspective.

Down to Earth

This book should appeal to anyone interested in environmentally appropriate construction. It's written in

a way that should make it comprehensible and useful for everyone from armchair architects to "green green" (novice and eco-friendly) builders to experienced contractors ready to take on a new construction medium. If any of those categories suit you, check this book out. There is also a companion video with the same title available from the publisher.

Access

The Rammed Earth House, David Easton, 1997. US\$30 from Chelsea Green Publishing Company, PO Box 428, White River Junction, VT 05001 • 800-639-4099 or 802-295-6300 • blackmer@chelseagreen.com www.chelseagreen.com

Author: David Easton, Rammed Earth Works, 101 South Coombs St., Studio N, Napa, CA 94551 707-224-2532 • Fax: 707-258-1878 • rew@i-cafe.net www.rammedearthworks.com

Reviewer: Richard Engel, 2705 Alliance Rd., Arcata, CA 95521 • 707-822-1884 • chard_e@yahoo.com



Backup & Renewable Energy Systems
For Homes, Cabins, & Other Applications

Be Prepared For Power Outages Due To Y2K, Weather, or Other

- Solar, Wind, & Hydro
- Gas, Diesel, & Propane Generators
- Trace, Solarex, BP, Winco....
- Full System Design & Tech Support



Call for FREE Information Price List Packet or Order Our Design Guide With Specs for \$20



Natural Energy Systems, Inc.

1902 Richard Court • St. Paul, MN 55110
Phone: (651) 428-9577
Fax: (651) 407-1333
Email: energysys@pelluk.com
Web: www.alternativepower.com

ELECTRIC CAR COMPONENTS & KITS

- *Reliable, Affordable Components
- *Large Library Of Adaptors
- *Most Experienced Tech Support
- *Design Assistance

Conversion Kits:

- **Basic & Deluxe Universal Kits*
Contain all drive system components. You add mounts, boxes, etc. to fit your model.
- **Complete Custom Bolt-In Kits*
Voltsrabbit for VW Rabbit, and *Voltsorsche* for Porsche 914. Completely prefabbed. No design or welding necessary. Kits include everything except donor car & batteries.

For Catalog, Send \$6.00 To:

ELECTRO AUTOMOTIVE
POB 1113-HP
FELTON, CA 95018



(Outside the U.S. & Canada, add \$5.00)

www.electroauto.com

Here's a brighter solution!
Forever Titan Solar Light

With an 18 watt fluorescent bulb, it is the brightest solar light on the market.

Fully recharged by the sun and portable, Forever Titan Solar Light is perfect for home, emergencies, camping and recreational activities.

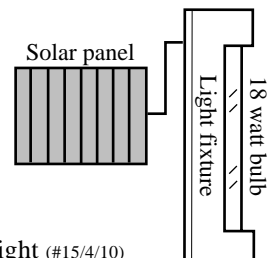

Get your Forever Titan Solar Light (#15/4/10) package for \$189. Call us now to order!

(Includes lighting fixture, solar panel, and cable. Sales tax and shipping extra.)

PO Box 591495, Dept. H
San Francisco, CA 94159-1495
415/831-6184 Fax: 415/831-6127
www.bellsolar.com

Visa/MC/Discover



Phoenix Composting Toilet System

Odorless • Waterless • Large Capacity
Low Energy Requirements • Owner-Friendly

Advanced Composting Systems
195 Meadows RD
Whitefish, MT 59937
Voice: 406-862-3854
Fax: 406-862-3855
phoenix@compostingtoilet.com
www.compostingtoilet.com

Sunergy Systems, LTD
Box 70, Cremona AB T0M 0R0
Voice/fax: 403-637-3973
sunergy@telusplanet.net
In British Columbia:
Voice: 250-751-0053
Fax: 250-751-0063

HAPPENINGS

CANADA

Alberta Sustainable House: Open 3rd & 4th Saturdays (except holiday weekends), 1-4 PM, free. Cold-climate features/products re: health, environment, conservation, AE, recycling, low energy, self-sufficiency, & appropriate technology. Autonomous & Sustainable Housing, 9211 Scurfield Dr NW, Calgary, Alberta T3L 1V9, Canada 403-239-1882 • Fax: 403-547-2671 jdo@acs.ucalgary.ca www.ucalgary.ca/~jdo/ecotecture.htm

The Institute for Bioregional Studies demonstrates & teaches ecologically-oriented, scientific, social & technological achievements. IBS, 449 University Ave, Charlottetown, Prince Edward Island C1A 8K3, Canada • 902-892-9578

Vancouver Electric Vehicle Association, call for meetings: 1402 Charlotte Rd., North Vancouver, BC V7J 1H2, Canada 604-987-6188 • Fax: 604-253-0644 rcameron@statpower.com

CHINA

Apr 18-21, 2000, Int'l Exhibition on New Energy, RE, and Energy Saving 2000, Shanghai. Kammy Shum, Project Manager, Coastal Int'l Exhibition Co., (852) 2827 6766 Fax: (852) 2827 6870 • www.coastal.com.hk general@coastal.com.hk

COLOMBIA

Oct 11, Expouniversidad 99—Energia, desarrollo y calidad de vida. Mechanical Engineering University of Antioquia, Medellin. Marina Carvajal, carvaja@udea.edu.co

INDIA

Oct 28, 29, 30, & 31, 1999: Smiles '99, J.N. Tata Auditorium, Indian Institute of Science, Bangalore, India. International exhibition & seminar on solar energy. Promoted by Unisun Technologies Group, an organization formed by experienced professionals to promote the application of solar energy & technologies in the developing world. Meet, interact, & transact business with Indian manufacturers, distributors, & consumers of solar products. Over 70 exhibitors, 700 delegates, & 50,000 people. Mathew Chandy, Project Manager Phone: 91-80-5597515 Fax: 91-80-5595207 or 91-80-5589054 unisun@vsnl.com or smiles99@vsnl.com www.unisun.net

PORTUGAL

Nov 10-14, International Exhibition on Environmental Technology, Energy & Natural Gas. Feir Internaciojnal De Lisboa, 351-1-360-1500 • Fax 351-1-363-3893 expoambiente@aip.pt • www.emml.com

NATIONAL U.S.

American Hydrogen Association nat'l headquarters: 1739 W 7th Ave, Mesa, AZ 85202-1906 • 602-827-7915 Fax: 602-967-6601 • aha@getnet.com www.clean-air.org

American Wind Energy Association. Info about US wind energy industry, membership, small turbine use, & more: www.igc.org/awea

Reports on State Financial & Regulatory Incentives for RE. North Carolina Solar Center, Box 7401 NCSU, Raleigh, NC 27695 919-515-3480 • Fax: 919-515-5778 www.ncsc.ncsu.edu/dsire.htm

Energy Efficiency & Renewable Energy Clearinghouse (EREC): Insulation Basics (FS142), New Earth-Sheltered Houses (FS120), PV: Basic Design Principles & Components (FS231), Cooling Your Home Naturally (FS186), Automatic & Programmable Thermostats (FS215), & Small Wind Energy Systems for the Homeowner (FS135). EREC, PO Box 3048, Merrifield, VA 22116 • 800-363-3732 TTY: 800-273-2957 • energyinfo@delphi.com www.eren.doe.gov

Oct 16, National Tour of Solar Homes. ASES, 2400 Central Ave #G-1, Boulder, CO 80301 303-443-3130 • ases@ases.org www.ases.org/solar

Fourth Annual Permaculture Design Course Online beginning Oct 24. Runs 5-6 months, depending on class needs. Includes reading assignments, emailed lectures and discussion, student reports, & a permaculture design. Leads to certification as a permaculturist. Dan & Cynthia Hemenway, PO Box 52, Sparr, FL 32192 YankeePerm@aol.com

Energy Efficiency & Renewable Energy Network (EREN), links to gov't & private internet sites & offers "Ask an Energy Expert" online questions to specialists: www.eren.doe.gov • 800-363-3732

Green Power web site: Discusses green power including deregulation, "green" electricity choices, technology, marketing, standards, environmental claims, & varying national & state policies. Global Environmental Options (GEO), & CREST: www.green-power.com

Kids to the Country, an ongoing program to show at-risk urban children a country alternative. PLENTY, 51 The Farm, Summertown, TN 38483 • 615-964-4391 ktc@thefarm.org

Tesla Engine Builders Association (TEBA): info & networking. Send SASE to TEBA, 5464 N Port Washington Rd Suite 293,

Milwaukee, WI 53217 • teba@execpc.com www.execpc.com/~teba

Sandia's web site, "Stand-Alone Photovoltaic Systems: A Handbook of Recommended Design Practices," "Working Safely with PV," & balance-of-system technical briefs, info on battery & inverter testing: www.sandia.gov/pv

Solar Energy & Systems, Internet college course. Fundamentals of small RE. Weekly assignments reviewing texts, videos, WWW pages, chat room, & email Q&A. Mojave Community College. \$100 plus \$10 registration. 800-678-3992 lizcaw@et.mohave.cc.az.us chacol@hal.mccnic.mohave.az.us

Federal Trade Commission free pamphlets: Buying An Energy-Smart Appliance, EnergyGuide to Major Home Appliances, & EnergyGuide to Home Heating & Cooling. EnergyGuide, FTC, Rm 130, 6th St & Pennsylvania Ave NW, Washington, DC 20580 • 202-326-2222 • TTY: 202-9326-2502 www.ftc.gov

The Interstate Renewable Energy Council, SEIA, & Sandia: handbook for government procurement officials & others on the specs & purchase of RE. US\$15 ppd (make checks to ASES), Interstate RE Council Distr Center, c/o ASES, 2400 Central Ave Ste G-1, Boulder, CO 80301

Solar curriculum for upper elementary & intermediate grades—Free! Six week science curriculum or individual sessions. Over 30 classroom presentations & demos using free or low cost materials. Student tested, teacher approved. Florida Solar Energy Center, Susan Schleith • 407-638-1017 www.fsec.ucf.edu

ALABAMA

The Self-Reliance Institute of NE Alabama seeks others interested in RE, earth sheltered construction, & other self-reliant topics. SINA, 6585 Co Rd 22, Centre, AL 35960 • cevans9@tds.com

ARIZONA

Tax credits for solar in AZ. A technician certified by the AZ Department of Commerce must be on the job site. ARI SEIA, 602-258-3422

CALIFORNIA

Campus Center for Appropriate Technology, Humboldt State University, Arcata. Ongoing workshops & presentations on alternative, renewable, & sustainable living. CCAT, HSU, Arcata, CA 95521 • 707-826-3551 ccat@axe.humboldt.edu www.humboldt.edu/~ccat

Siemens Solar PV training: Basic PV Technology Self-Study Course, & Comprehensive Photovoltaic System Design Seminar. Siemens Solar Training Dept, 805-388-6568 • Fax: 805-388-6395 cvernon@solarpv.com • www.solarpv.com

Institute for Solar Living, Sustainable Living Workshops through October '99. Beginning & advanced solar electric systems, passive solar, ecological design, sustainable waste water design, straw bale, cob & rammed earth construction, & more. ISL, PO Box 836, Hopland, CA 95449 • 800-762-7325

NCSEA Sacramento Solar Speaker Series, SMUD Customer Service Center, second Monday of every month, 7 to 9 pm. 916-44-SOLAR

Energy Efficiency Building Standards for CA. Download or hard copy. CA Energy Commission, 800-772-3300 www.energy.ca.gov/title24 Questions about Title @4 to: CALLCNTR@energy.state.ca.gov

COLORADO

Solar Energy International, hands-on workshops. One & two week sessions: PV Design & Installation, Advanced PV, Wind Power, Microhydro, Solar Cooking, Environmental Building Technologies, Solar Home Design, & Straw Bale Construction. Experienced instructors & industry reps. For owner-builders, industry technicians, business owners, career seekers, & international development workers. \$500/week. SEI, PO Box 715, Carbondale, CO 81623 • 970-963-8855 Fax: 970-963-8866 • sei@solarenergy.org www.solarenergy.org

National Wind Technology Center, Golden, CO. Assisting wind turbine designers & manufacturers with development & fine tuning. 303-384-6900 • Fax: 303-384-6901

FLORIDA

Dec 10-11, 1999: Solar Electric Home for the South. FLASEIA workshop: learn to design, size, and install a solar electric system in your future home. Integration of the Energy Star Home with solar modules, generator and/or utility backup or interconnection. Learn what makes a home comfortable in hot, humid climates. \$125 for 2 days. Energy Conservation Services, 6120 SW 13 St., Gainesville, FL 32608 352-377-8866 • Fax: 352-338-0056 tom@ecs-solar.com

GEORGIA

Nov 17-20, N American EV & Infrastructure Conference '99, Atlanta, GA. EVAA, 601 California St #502, San Francisco, CA 94108 415-249-2960 • Fax: 415-249-2699 ev@evaa.org • www.evaa.org

IOWA

Iowa Renewable Energy Association (IREA) meets 2nd Sat every month at 9 AM, Prarie Woods, Cedar Rapids. All welcome. Call for schedule change. I-Renew, PO Box 466, North Liberty, Iowa 52317 319-338-3200 • irenew@irenew.org www.irenew.org

KENTUCKY

Appalachia-Science in the Public Interest.

Projects & demos in gardening, solar, sustainable forestry, & more. ASPI, 50 Lair St., Mt Vernon, KY 40456 • 606-256-0077 aspi@kih.net • www.kih.net/aspi

MASSACHUSETTS

Greenfield Energy Park needs help preserving Greenfield's historic past, using today's energy & ideas, creating a sustainable future. Greenfield Energy Park, NESEA, 50 Miles St, Greenfield, MA 01301 413-774-6051 • Fax: 413-774-6053

Oct-Dec, Sustainability Series, workshops & lectures. NESEA, 50 Miles St, Greenfield, MA 01301 • 413-774-6051 • Fax: 413-774-6053 nhazard@nesea.org • www.nesea.org

MICHIGAN

Tillers International, classes in draft animal power, small farming, blacksmithing, & woodworking. Tillers Int'l, 5239 S 24th St., Kalamazoo, MI 49002 • 616-344-3233 Fax: 616-344-3238 • TillersInt@aol.com www.wmich.edu/tillers

MONTANA

Sage Mountain Center: Life Skills Workshops. One day classes: inexpensive earth-friendly home building, straw bale construction, log furniture, cordwood construction, natural & non-toxic interiors, & more. \$55 incl literature. SMC, 79 Sage Mountain Trail, Whitehall, MT • 406-494-9875

NEW MEXICO

Profit From The Sun workshops, Moriarty, NM. Renewable energy, energy conservation, sustainable living, & energy independence. James or Marek at PSF, Inc., 505-281-1300 days • James at 505-832-1575 eves & weekends • proffit@flash.net

NORTH CAROLINA

How to get Your Solar-Powered Home: RE seminars through summer of 2000. Solar Village Institute, PO Box 14, Saxapahaw, NC 27340 • 336-376-9530 • solarvil@netpath.net

OHIO

Solar/wind classes. Second Saturday each month, 10 AM to 2 PM. Tech info, system design, NEC compliance, efficient appliances. Register in advance. \$65, \$85 w spouse. In spring: hands-on straw bale post & beam building. Solar Creations, 2189 SR 511 S., Perrysville, OH 44864 • 419-368-4252 www.bright.net/~solarcre

OREGON

Aprovecho Research Center, non-profit educational institute. Six week winter internship in Baja, Mexico: Study & research appropriate tech applications, learn Spanish, teach grade school, & work fruit orchards & gardens. Internship Coordinator, Aprovecho Research Center, 80574 Hazelton Rd., Cottage Grove, OR 97424 • 541-942-8198

Oct 2, Solar Energy Association of Oregon: 20th Anniversary Conference, World Trade Center, Portland. Speakers Jeff Cook, Passive Solar Architect & Educator from AZ

State Univ., & John Reynolds, Univ of Oregon, Building Energy Specialist, Curtis Framel, Million Solar Roofs, & Larry Sherwood from the Am. Solar Energy Society. Trade Show (open to the public), Building projects & workshops, solar energy specialists. SEAO, 205 SE Grand Ave, #202, Portland, OR 97214 • 503-231-5662 www.oikos.com/seao

TEXAS

The El Paso Solar Energy Association bilingual web page. Info in Spanish on energy & energy saving. www.epsea.org www.epsea.org

WASHINGTON

Solar Energy International hands-on workshops in the San Juan Islands: Oct. 3, RE for the Northwest, \$75. Oct 4-9, PV Design & Installation, \$500. Oct 11-15, Microhydro Power, \$500. SEI, POB 715, Carbondale, CO 81623 • 970-963-8855 Fax: 970-963-8866 • sei@solarenergy.org www.solarenergy.org Or ianw@pacificrim.net for local information.

GreenFire Institute: workshops & info on straw bale construction. GreenFire, 1509 Queen Anne Ave #606, Seattle, WA 98109 206-284-7470 • Fax: 206-284-2816 wilbur@balewolf.com • www.balewolf.com

WISCONSIN

Midwest Renewable Energy Association (MREA) Workshops. See ad. Call for cost, locations, instructors & further workshop descriptions. MREA Membership & participation: all welcome. Significant others half price. MREA, PO Box 249, Amherst, WI 54406 • 715-824-5166 • Fax: 715-824-5399 mreainfo@wi-net.com

Oct 4 & 5, 1999: Clean Energy in Wisconsin "The Doors are Opening" conference. Paper Valley Hotel, Appleton, Wisconsin. Tours of nearby clean energy installations (PV, biomass, & wind), trade show, workshops. Keynote speaker: Thomas R. Casten, author of *Turning Off the Heat*, & President & CEO of Trigen Energy Corp., a power company using 1/2 the fossil fuel & pollution of conventional generation. Hosted by RENEW Wisconsin. Conference contact: Michael Vickerman, 608-255-4044 mjrenew@mailbag.com; Trade show contact: Andrew Olsen, 608-243-9071 andyo@inxpress.net; RENEW Wisconsin, 222 S. Hamilton St., Madison, WI 53703 Fax: 608-255-4053



**Taking
advantage
of the
Kyoto
Protocol?**

Emission reduction
evaluation,
certification
and certificate
trading for
renewable
energy system owners.



www.icbe.com

Wood Fired Water Heaters

For Homes, Cabins, Camps, Remotes,
Solar Booster, Hot Tubs, Pools, Greenhouses!
USA Made • 3 Models • 10 Yr. Warranty



Hot Products, Inc. • Dept. HMP • 300 Broadway • Eureka, CA 95501
Tel: (707) 444-1311 • Fax (707) 444-1380 • www.hotpro.com

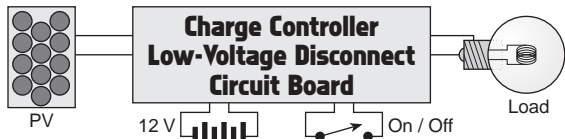

As featured in *Home Power* #60 and #63

Blank PC board \$20 • 8-Amp kit \$45 • 8-Amp assembled and tested \$60

Send check or money order to:

Eklektix, Inc., 2910 Carnegie Dr., Boulder, CO 80303
www.eklektix.com/solar • sales@eklektix.com

STEAM POWER

www.sensiblesteam.com

ENGINES BOILERS GENSETS

Books, vids, info: call 417-336-2869

THE ORIGINAL MULTI-ARRAY White LED Flashlight

The most practical flashlight ever made!



\$34⁹⁵
Price Includes
Batteries & Shipping
Made in U.S.A.

Lasts Over 50 Hours
on 3 'AA' Alkaline
Batteries

**It's
Waterproof!**

**Unbreakable LED
Bulbs Last
Thousands of Hours**

**C. CRANE
COMPANY**

Call 1-800-522-8863
To Order or for a FREE Catalog
Visit Our Website at c crane.com

BackHome
b/w on negative

3.0 wide
5.8 high



**Solar - Powered
Soap?**

The natural ingredients of
our soaps and bodycare products
derive their energy from the Sun, as
do our home and business.

Discover the many items for home
and personal care in our catalog:
Simmons Handcrafts.

42295 Hwy 36, Bridgeville, CA 95526



the Wizard speaks... Reflections

Anomalies

Many times anomalies are discovered in science. These are phenomena that do not fit the current paradigm. These anomalies should not just be shrugged off or ignored. It is through the study of such phenomena that a new and more comprehensive understanding arises. The anomalies of today will lead to the theories of tomorrow.

Dimensions

Our universe consists of three spacial dimensions and one temporal dimension. Many of today's theories rely on an additional set of dimensions in order to accurately model this physical universe. This does not mean that

there are actually more than four dimensions. All it implies is that, at the present time, it is necessary to postulate a set of higher dimensions in order to model the four dimensional universe. These extra dimensions may or may not exist in reality.

Time Perception

Quite often one's subjective perception of time differs significantly from an objective measurement of the same interval. Our subjective perception of time is based on the number of events processed in any interval. If we process less than our normal number of events per interval, the interval appears shorter. Conversely, an interval with a larger than normal number of events appears longer.

Reality and Perception

We tend to create our own internal realities through the ordering of our perceptions. The ordering of perceptions may be seen as analogous to the collapsing of the quantum wave function. Similar ordering creates a similar reality. In this way consensus reality emerges. The greater the difference between the ordering of perceptions and its norm, the more an individual reality diverges from the consensus. It may be possible, in part, to reorder one's perceptions and move one's reality toward or away from the consensus reality.

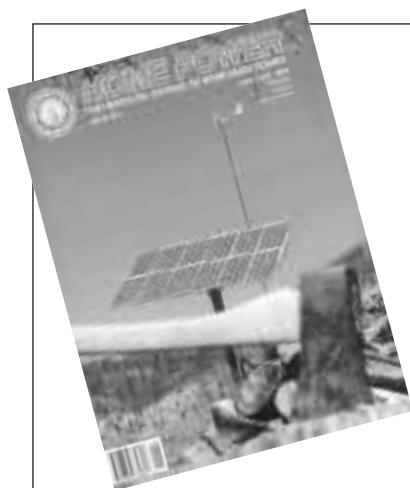

Back Issues of Home Power !

Check out our Web site www.homepower.com ...
It contains an index of all articles back to issue #1.

You can buy back issues individually:

- \$3.25 each for 17 through 20
- \$4.75 each for 21 through 45 (except for 25, 35, 36, 38, 40, 41)
- \$5.75 each for 46 through 72 (except for 59-61, 63-65, 67)

- OR -

Deal #1: All available back issues for \$100

Deal #2: 6 or more issues (of 21 through 73) for \$4.00 each (*sent bound printed matter*).

for U.S. ZIP codes only, see page 81 for international back issues.

Check with your local library—through interlibrary loan you can get back issues.

The Jackson County Library in Oregon and the Alfred Mann Library at Cornell University have all issues.

Or, get the CD-ROMs—*Solar2 (HP1-HP42)*, *Solar3 (HP43-HP60)* and *Solar4 (HP61-HP70)*.

Home Power, PO Box 520, Ashland, OR 97520 • 800-707-6585 • 541-512-0201



Good Info!
Good Deal!
800-707-6585
in USA

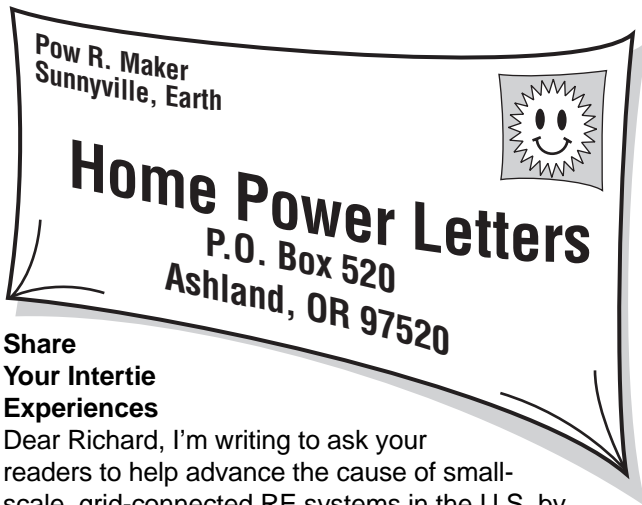

Share Your Intertie Experiences

Dear Richard, I'm writing to ask your readers to help advance the cause of small-scale, grid-connected RE systems in the U.S. by sharing the experiences they have had in trying to obtain "legitimate" interconnections from their local utility and/or local municipality.

As you know, much of my work in recent years has been dedicated to streamlining the process by which homeowners and businesses can interconnect their small RE systems to the utility grid. I've worked for years on a case-by-case basis with RE system owners who are struggling over interconnection issues. Those of us involved in these efforts are very familiar with the types of problems that are frequently encountered. But there has never been any systematic effort to document these experiences and present them to policymakers (such as state and federal lawmakers and utility regulators) who are in a position to really make a difference. So that's what I intend to do.

As you know—since we talked about it in person at the ASES 99 conference—I think the real heroes of the home power movement are those who go through the struggle of working with their utilities and their municipalities in an effort to comply with the often burdensome interconnection requirements that are imposed on them. I'm hoping (perhaps naively) that most of the Solar Guerrillas who are writing to *Home Power* have first tried to obtain a legitimate interconnection and have been so discouraged (or outraged) that they have given up and "gone guerrilla." If that's the case, then there should be some great stories out there among your readers!

Since I have to balance the need for credible, documented information against your readers' desire for confidentiality, I'm going to ask that any correspondents include names and contact information so I that can follow up with them and verify their accounts. In return, I will promise not to pass on any identifying information (name, address, interconnecting utility, etc.) without their express permission.

Stories should include the obvious information: type and size of RE system, components of the system, and a description of the interconnection experience. Incidentally, I am also interested in hearing from readers who encountered few or no problems with their interconnections (it does happen...).

If I get a healthy enough response, I'll write a follow-up article for *Home Power* summarizing the findings and suggesting what we can do to make interconnecting our small-scale RE systems simple and legal!

Help pave the way for the next generation of RE users! Write now! Readers interested in helping can write or email me. Tom Starrs, Kelso Starrs & Associates LLC, 14502 SW Reddings Beach Rd., Vashon, WA 98070 kelstar@nwrain.com

Hello Tom, and thanks for giving HP readers a chance for input. Most HP readers have heard about your good deeds, but for the folks new on the scene, I'm going to tell them a little about you.

Tom is a lawyer whose work has resulted in most of the new state net metering laws in the United States. He was instrumental in getting Oregon's net metering bill written and passed. He is a staunch supporter of small-scale renewable energy. Readers, please share your grid intertie experiences with Tom. Richard Perez

Induction Motor Hydro Formula Correction

Dear *Home Power*, I really appreciated the hydro articles in *HP71* and also Paul Cunningham's letter in *HP72*. Let's have more hydro! It really is so much more effective than wind and solar. I have been doing small wind energy for twenty years, and it hasn't been easy. I started dabbling in hydro about five years ago and it's so simple! On a good site you can have hundreds of watts, or even kilowatts, of continuous AC power, with no batteries and minimal cost. In my experience, the reliability is much better than wind power, and the efficiency can be very high too. The main hassle is the intake filter, and even that problem is solved in *HP71*, for those who can afford the Aqua Shear screen.

Induction motors can be very efficient as generators of AC power on direct AC systems without battery charging. Combined motor/pump units can make very efficient and cheap hydro turbines too, if correctly matched to the site. I have seen overall efficiencies around 60 percent. Induction motors can be rather disappointing for battery charging, and Paul has done an excellent job of pointing out why, in his letter in *HP72*. I believe that the key things to avoid are: low frequency, small motors, and single-phase systems. Better still, use one of Paul's purpose-built permanent magnet alternators!

In his letter, Paul questioned Bill Haveland's measurement of efficiency, and his system design. Of course Bill is not around to reply, but I had a similar email exchange with Bill before his article was published, and he gave me some answers. Here is what he said:

Measurements were made with a Fluke 39. I bought this very useful meter to accurately measure these systems. The Fluke 39 measures VA and true power, with a power factor reading also. Water was measured with a seven gallon plastic bucket and stopwatch, which is inherently pretty accurate. Several readings and then an average were taken. The water pressure was a weak point. I used the gauges installed on the systems, which were cheap hardware store types.

When I set these up, with the exception of Richard Lebo's which was done by Fred Howe's method, I substituted capacitors until they peaked out. I have a box with about 150 motor run caps, so I did as accurate a job as could be done, I feel. In calculating the optimum rpm for peak runner efficiency, I find Bosque is about 800 rpm too fast (needed the extra rpm for transformer efficiency), Buena Vista nearly perfect, Casa Corcovado about 500 rpm too slow, Richard Lebo's system nearly perfect, and Joel's a couple hundred rpm too fast. All in all, they peaked up fairly near what I would expect. The capacitors come in several point spreads and I didn't get into series and parallel configurations for a few more watts, so that may be part of it.

I would really like to get to the bottom of the efficiency thing. To this end and also the Trace inverter backfeed, I'm setting up a test site...

Of course this project never reached maturity. I too would have been very interested to see if a Trace SW series inverter could run on an induction hydro, and one day someone will try it.

Bill also pointed out that the power formula in his article was botched. "Too bad, as that will have long range repercussions," he said. Just to put the record straight, power (in KW) is equal to head (in meters) times flow (in cubic meters per second) times efficiency (as a decimal fraction) multiplied by *TEN*. For example, on a site with 20 meter head and 1/100 cubic meter per second flow (10 litres/second), you might expect about 1 KW of power, if the overall efficiency is 0.5. Using the formula as published would have given one milliwatt for this site, which might have caused some confusion!

Finally, I would like to mention an internet email list where we all exchange views and free advice on hydro topics (www.itc.nl/~klunne/hydro/index.html#list). Happy hydro, everyone! Hugh Piggott, Scoraig, Scotland

+44 1854 633 286 • Fax: +44 1854 633 233
hugh.piggott@enterprise.net
<http://homepages.enterprise.net/hugh0piggott>

Alternatives to Alternative Fuels

Hi. I just read *The Future of Transportation*, by Joshua Tickell. It really tells it like it is on the true cost of fossil fuels. The recent price hikes are the start of a price rise to US\$30+ a barrel. The good thing is that at \$20 to \$30, all types of RE become competitive (alcohol, veggie oils, and biomass destructive distillation) and some become downright cheap (wind at \$.06 KWH and solar thermal at \$.07 KWH). Of course, conservation (insulation, lighter and more efficient cars, etc.) is the biggest bargain of all. I don't worry about this because I can make RE cheaper for my home and car—can you? I support a carbon tax to kickstart alternatives, and conservation to slow the oil price rise.

On fuel cells, they never say how much energy they use to make hydrogen. They end up only 20 percent efficient. A natural gas (methane) internal combustion engine set up right is 40 percent efficient and has lower emissions. It's too bad about Amory Lovins pushing fuel cells (Fool Cells?). He did so much good in conservation. It's good that his hypercar is efficient—with a fuel cell powering it, he will need all the efficiency he can get.

Methanol is a poisonous, corrosive, low-energy fuel. Ethanol can have a better balance ratio by using leftover mash for animal feed. It has twice the food value of grain. Alcohol can be made at fifty cents a gallon. Distillation of grain stalks gives more energy. This kind of energy/food farm is the future of farming.

Hybrid vehicles don't have to be complex or expensive. I'm building a two seat, 60 mph, 80 mile range electric vehicle. It will weigh 1,200 pounds, with batteries, two wheels in front and one in back, and a high tech wood epoxy body and frame. (I build epoxy wood boats, wing masts, and other structures for a living.) It cost \$1,200 for parts. Why build a second car for biodiesel? Just use it in the hybrid generator. I could charge a house or business with it, too. It could also be powered on methane.

Josh left out the best biofuel—hemp. You will get one pound of diesel-type fuel for every ten pounds of dried plant, and other burnable gases, by destructive distillation of hemp. Hemp needs little water, pesticides, fertilizer, or care. Here in Florida, we'd get four crops a year! Self sufficiency is security, and knowledge is power. Keep up the good work. Jerry Dycus, Riverview, FL

Jerry, you brought up some important points. The coming price increase in fossil energy will have a

tremendous effect on the renewable energy (RE) industry. As fossil energy costs increase, so does the demand for RE. I agree with you that conservation is the most cost-effective means of increasing the efficiency of our current energy systems.

I'm glad you mentioned carbon tax. State and federal governments are beginning to offer minimal tax breaks for clean fuels (to find out which states are doing this, see www.afdc.doe.gov/documents/taxindex.html).

Just to set the record straight, I am neither for nor against fuel cells and the folks who promote their use. Fuel cells will one day be very useful in niche applications such as on the space station and as an integrated component of certain industrial power plants. But as you pointed out, using a fuel cell to power a vehicle is no more efficient than using a conventional internal combustion engine. Please keep us up to date on your DIY hybrid vehicle. It sounds a lot less expensive than Toyota's hybrid Prius. Joshua Tickell biodiesel@best.com

Net Metering—Wind Without Limits

In Tom Starrs' latest summary of net metering legislation in the U.S., there is a worrisome trend. Of the 30 states with net metering, only four (less than 15 percent) permit net metering for any size wind turbine the customer chooses. In this age of "customer choice," the customer should indeed have a choice about the size of wind turbine they want to use under net metering programs. Most programs limit wind turbines to 10 KW or less. Some permit 50 KW or less. A few go as far as permitting 100 KW. But only Iowa, New Jersey, Ohio, and Connecticut have the foresight to permit wind turbines as large as the customer chooses.

The only argument for setting limits or "caps" on wind turbine size is to protect utility markets. As advocates of renewable energy, we should not be in the business of protecting electric utility markets. The utilities do quite well on their own without our help—quite well indeed.

Advocates of net metering should explicitly—and aggressively—demand "wind without limits" (or renewables without limits if you prefer) in our campaign for net metering. We shouldn't settle for less. If we do, wind and other forms of renewable energy will once again be shortchanged. We may not get another chance.

Net metering is self limiting. We don't need to add artificial limits. Only those who can make use of larger generators will choose them. Customers such as Shafer Industries and Spirit Lake school will opt for larger turbines because it makes economic sense to do so. Those for whom a 10 KW machine makes sense

will choose a 10 KW machine. We shouldn't make that choice for them.

Net metering should be open ended, without caps, and provide for pooling of loads among residential as well as commercial customers. This will permit cooperation among users to install the wind turbine that makes the most economic sense for them.

If you're interested in taking action on this issue, send a message to Tom Starrs (kelstar@nwrain.com) and ask him to take the shackles off renewable energy and demand "net metering—wind without limits." Paul Gipe, 208 S. Green St. #5; Tehachapi, CA 93561-1741 661-822-9150 • Fax: 661-822-8452 • pgipe@igc.org

Fuel Cell Efficiency

I wanted to make a few comments about *HP72*. For the sake of your readers, you might have mentioned that distilling ethanol is illegal in the U.S. without special license. I thought the efficiency of internal combustion electric generators was more like 25–30 percent, not the 10–20 percent mentioned in the article.

Also, there is a quote that the electrical efficiency of the fuel cell is almost double that of other non-renewable sources. If one takes the 39 percent efficiency given in the table on page 28, and multiplies by the 70 percent average efficiency of boilers for steam production, then the actual overall efficiency is more like 27 percent.

The only other article I've read so far is the one on biodiesel. A little tidbit about the purpose of the methoxide: it reacts with the oil to make esters. Esters from methanol and ethanol are highly flammable.

I guess I should mention that I do enjoy *HP* (I have it linked from my engineering links page). I helped Brent Van Arsdell work out a few problems on his Stirling engine years ago and suggested he write an article for you. I think that was published in late 1997. Mike Brown ChemEngr@FoxValley.net <http://users.FoxValley.net/~chemengr>

Mike, I have to admit you really had me going until you finally admitted you "enjoy" HP at the end. Lots to cover. First, as a native of the hills of Kentucky, I have to say that this stuff about illegal ethanol is new to me (grin). Maybe we could think of it as another form of "Guerrilla Power."

About generator efficiency: I did find a few larger, low rpm diesel gensets with efficiencies approaching 25 percent, but most smaller gas generators fall well within the 10 to 20 percent range mentioned. A Honda EX 5500, for example, burns 0.8 gph of gasoline to produce 5.0 KWH for an 18.5 percent chemical efficiency. A smaller 2.5 KW Honda was closer to 16 percent. Of course that is at max rated power.

Any idle or low power time greatly reduces this efficiency. While I agree that the steam produced for use in the reformer may have a 70 percent efficiency, this is just a small portion of several parallel processes that occur in the fuel processor. The figure given for the overall efficiency is a ratio of the electrical energy output divided by chemical energy consumed by the fuel cell system.

To calculate the approximate efficiency of any genset:

Chemical efficiency = BTU output / BTU input

BTU output = Genset rated KW x 3412

*BTU input = Fuel units consumed per hour
x BTU rating of fuel per unit*

A few common fuel BTU ratings:

Propane = 115,000 BTU / gallon

Gasoline = 91,500 BTU / gallon

Methanol = 142,000 BTU / gallon

Diesel = 63,000 BTU / gallon

Unfortunately, about the only article in HP72 I haven't read yet was the one about biodiesel, but your warning concerning the extreme flammability of esters is well stated and clear. Thanks for the caution and also for inspiring Brent to contribute his past article to HP.

*Regards! Russ Barlow • 320 Oak Grove Ct., Wexford, PA 15090 • 724-935-6163 • Fax: 724-935-0745
srbarlow@nauticom.net*

Stirling Cogenerator

Dear Richard, Karen, and the *Home Power* crew, as Karen puts it, most of us on solar power enjoy having our nuclear energy source 93 million miles away. But now that *HP* has given flowers to the GennyDeeCee, I'd like to mention that there may be an attractive, cleaner burning cogenerator on the horizon for *HP* readers in cold climates who need both heat and backup power.

Last year, an *HP* subscriber and relative of mine, Anders Berg, informed me of a Philips/Carlquist helium-charged Stirling cogenerator engine for home use. It's being developed by a Norwegian company in cooperation with several government agencies and universities, as well as various European utilities and, yes, environmentalists.

Their remarkably efficient unit burns less than 1/2 gallon of propane an hour, putting out 265 gallons per hour of 158°F water for space heating and domestic use while generating 3 KW of AC or 24 VDC.

That translates into an 88 percent energy conversion efficiency and the 1,600 rpm, 40 decibel unit is small enough to be installed under a kitchen counter. Multiple standard units are anticipated to be used in remote hospitals or small commercial enterprises like laundromats.

Hermetically sealed much like a refrigerator compressor, the Philips/Carlquist unit's life expectancy is presently 50,000 hours, with required maintenance every 5,000 hours. Multiple units installed in England in November, 1997, and in Norway in June, 1998, and several single home units assembled and installed by a plumbing company in Oslo, Norway are presently being tested and evaluated. When the evaluations are done, the company intends to manufacture approximately 2,000 demonstration Stirlings.

The cost of these engines as a cogenerating unit with the associated plumbing appears expensive, but may be ideal for homes where the water heater currently is plumbed into radiators or floor heating coils, and the water heater is going bad.

It may take some time before these cogenerators will be available in the U.S., but I, living alone in an 860 square foot cabin at 4,000 feet elevation with a propane water heater, some 48 watt panels, and using an average 3 KWH per day, could have used one this winter. Dag Heistad, Soulsbyville, CA

Hello Dag. Thanks for the info. We've had a lot of interest in Stirlings lately. Check out the article by Brent H. Van Arsdell, Stirling Engines for Home Power in HP61, page 20. Stirling engine cogenerators look very attractive for many situations, but are not right for all.

The 50,000 operating hours is a ten-fold improvement over other Stirlings I have heard of over the years. But as you say, they are still expensive, and rebuilding or replacing the engine will also be very expensive even if they do last as long as predicted.

At the Midwest Renewable Energy Fair this year, I saw a Stirling demonstrated that ran on solid (pelletized) fuel. It used water as a coolant, but had a very attractive feature. Rather than running a generator via a crankshaft and its necessary bearings, it relied strictly on a back-and-forth motion that moved a magnetized field through a coil. I foresee a much longer life for this type of engine, which doesn't have sealed bearings or a crankcase. This company is Sunpower, Inc., PO Box 2625, Athens, OH 45701. Michael Welch

PV Pioneering Project

Hi Richard, I just got *HP72*. It's great as usual. It got me to thinking about the fun solar project that I did this summer.

My son's Boy Scout troop went to summer camp in June and I went with them. Since I write software and do design work for my own company, I don't get paid for vacations. So I decided to take my computer with me for a little work. The problem was how to power it for a week. Well let's see, sunny southern California...solar! So I borrowed a bunch of solar panels (four Siemens



M55s), batteries (six 6 volt golf cart batteries), and a charge controller (from an LED-based changeable message sign company that I often work for).

Off to Camp Mataguay we went, with our poor Subaru station wagon loaded way beyond maximum weight! When we got there, the boys built a lashed tower to hold the panels ten feet off the ground and a power pole to bring the extension cord over a trail. At night, we had two 25 watt compact fluorescent bulbs for lighting (the bugs loved them), a small peltier junction refrigerator chilling sodas for the leaders, and I had all the power I ever wanted for my laptop.

The kids won an award for the tower as “the most imaginative pioneering project in camp.” They also learned the value of solar and just how much power was available from the sun. I’ve attached a couple of pictures—I hope they tickle your funny bone as much as the camp staffs’. Rick Roberts
kingkozy@pacbell.net

Driving to MREF vs Flying

Dear Richard, in response to your story about driving to Wisconsin last year, I thought I might share some information you may otherwise not have access to.

You mentioned the 500+ gallons of gas you burned driving roundtrip to the Midwest Renewable Energy Fair in your rented RV, and wondered if flying might not be more efficient. In a nutshell, yes, it would be. As an example, if you flew from Portland, Oregon to Chicago, Illinois, typically it would be on a Boeing 757, or similar aircraft. The flight would take about four hours, the aircraft has seating for 188 passengers and seven crew members, and would burn about 22,000 pounds, or 3,300 gallons of aviation fuel flying 1,754 statute miles.

In the transportation business, we have a formula for comparing fuel efficiencies for various modes of travel, known as Seat Specific Fuel Consumption (SSFC). To compute it, simply take the miles per gallon for any vehicle and multiply it by the number of passengers the vehicle can carry. Using this formula, we can compare jet skis to jet airplanes and anything in between.

In the case of the Boeing 757, it has an SSFC of 99.7, meaning it can carry one passenger 99.7 miles on a gallon of fuel. Assuming your RV gets 10 MPG, and traveling the same 1,754 miles; with six passengers, its SSFC would be about 60, or nearly half the efficiency of the 757. To achieve the same efficiency as our aircraft, you would simply have to put ten people in your RV. This may not be legal, or desirable, depending on how well everybody gets along.

None of this accounts for the fact that a three day drive across North America could be flown in under four hours by traveling at speeds in excess of 500 mph. Even if you could get an RV to travel that fast, I doubt you would enjoy the fuel economy you do now. We could also consider the fact that a plane can fly 1,700 miles in a near straight line, where a vehicle is at the mercy of existing roads, typically extending the mileage driven by 20 percent or more for travel between the same two points. Offsetting this, however, is that to get to Wisconsin, you would probably have to make a connection, adding perhaps two hours and 200 miles to your flight.

Having studied transportation for four years at school, and working in the field for nearly half my life, I am

regrettably aware that all forms of travel can be fraught with problems. It would be difficult to factor in the time you might waste if your flight were delayed for bad weather or mechanical problems. As an experienced RVer yourself, though, I'm sure you're aware that even an RV can fall prey to bad roads, construction, traffic, weather, and the occasional mechanical irregularity. The question that remains next time you travel then, is this: What mode of transportation will best balance your needs with the needs of our environment?

I would like to add that we have been reading your magazine for several years now, and have recently installed a small system to "test the waters" of renewable energy at our location. Our AIR 303 windplant and Solarex 53 watt panel have been producing power in excess of our expectations for most of the last year. Aside from some installation errors with the windplant, it has all been working flawlessly. We are planning a full-sized system to be completed in a few years, and in the meantime have been working to make our place more energy efficient. Thanks to the metering and monthly statements our utility company has been providing us for the last ten years, we won't have to bother with a load analysis. Once our house is in order, we simply need a system that can produce as much power as we are currently importing. Regardless of how affordable electricity is, we are all convinced that this is a worthy cause. Please keep up the good work. Rudy Ruterbusch, Elberta, MI

Hello Rudy and thanks for the info on air travel. We had eight people aboard the RV on this year's trip to MREF. We also had over one ton of magazines, books, and booth stuff. We scoped the scene both ways, via air and via RV, and it was way cheaper to drive the RV. If we'd flown, we'd have had to rent a big vehicle for local travel and also shipped all the magazines. Air travel for this whole demented scene figured to be about twice as expensive as driving the renta-RV. Also, the Home Power crew mostly telecommutes, so we enjoy getting sealed into that RV and hurtled through space for days—it's the only time we all get to face-to-face visit with each other. Richard Perez

Leave it to a Home Power reader to give us a detailed, technical analysis of our travel options! Thanks, Rudy, and good luck with your growing system. Your analysis is fascinating and entertaining. Richard's last point is the strongest one for me. As the newest HP crew member, I really enjoyed having time to get to know my co-workers, get some work done via pen and voice instead of keyboard and modem, and just have a good time together. I think those things are hard to put dollar or environmental values on. Also, the RV served as the HP entertainment spot and housing for some of us at

MREF. On top of all that, the sushi is better on the road (even in Montana) than in the friendly skies... Ian Woofenden

Earth, Stucco, & Rain

Dear *Home Power* crew, I can't believe Kathleen is to retire. I've only spoken with her a few times, but each time was enjoyable. She never seemed to be in a rush to conclude business and hang up. She gave me the time of day, so to speak. She'd even answer a question about her current project, or share some good news. An easy person to talk to, Kathleen was an asset to *Home Power* in that capacity. Her voice will be missed. It is good news that she'll continue to write and remain part of your fine crew. Viva Kathleen!

An earth stucco question: Isn't it because the finished surface is protected from rain that it will hold up? My thinking is that even the best clay will reabsorb moisture and become workable again unless it is fired. Have you applied a sealant of some kind? If so, was that less expensive in the long run—fun aside—than commercial mixes which are ready for the weather upon drying? Regards to all, James R. Wirth, PO Box 369, Heber, AZ 85928

Hello James, Big overhangs definitely keep the majority of weather off of the earth stucco on the bathhouse. Windy conditions do wet down the west wall quite often. We opted to keep the surface highly breathable and not apply any sealer. This allows the surface to dry quickly after it does become wet. In drier climates, like the southwest, this system has been used for centuries. In wetter climates like the Pacific Northwest, a synthetic stucco is probably a good idea. To date, the bathhouse here has performed well with no oil-based stabilizers or cement used in the stucco. Joe Schwartz

Rohn Towers

Dear *Home Power*, I've been a subscriber for about four years now. I can't tell you what a great job you're doing for the whole planet. Thanks to you and your mag, I now have a 1 KW array on my roof and I am very proud of it. Some day I hope to write an article for *Home Power*. I still have a little more to go before that though.

My question is this: I want to put up a wind generator behind my garage. I am limited in space as I live in a semi residential area, so I thought I'd use a Rohn tower guyed in the small area that I have available. Is this a good idea? I am getting confusing info from different sources. I want to make sure that it is safe. I wanted to put up a Rohn 25G tower, but some say use a 45G tower. Can you put me in touch with someone who will give me the straight dope? Thanks. God bless you guys, and God bless solar guerrillas. Doyle L. Lonski DLLONSKI@cs.com

Hi Doyle, thanks for your kind words. We'll look forward to seeing the article on your system when you get to it.

Some people have successfully put wind generators up in residential areas, but there are certainly problems. First of all, you have to live with your neighbors, so talk with them about it. If you can't get their support, why sour the relationship? How big is your yard? I've talked with a guy in Illinois who has a wind generator in a residential area. He had only a few feet between his house and his property line to site the tower. He put up a freestanding tower because he had no space for guy wires, and it sounds like you may be in a similar situation. Guy wires ought to be anchored 40–70 percent of the tower's height away from the base.

As far as the specific tower model for your machine, that depends on what machine you want to put up. Check with the manufacturer for recommended tower size. Or read on for the straight dope from Mick. Ian Woofenden

Doyle, the Rohn 25G guyed towers have been used as wind generator towers for decades. They can handle up to a 10 foot rotor diameter (5 foot blades). The 45G is a larger tower, capable of handling up to a 16 foot rotor diameter. As far as height, the rule of thumb is to get the entire rotor a minimum of 30 feet above the surrounding obstacles—trees and buildings. Below that, you're in the turbulent zone, and turbulence will not only diminish your power output but will also eat up the turbine in wear and tear. Don't skimp here.

You didn't mention what wind generator you plan to install on the tower. If you plan to install a larger turbine later on, then go with the bigger tower now, the 45G. If you never plan on increasing your wind capacity, then the smaller tower may do, provided you follow the above rotor diameter guidelines. Installing a larger rotor than the tower is engineered for is inviting disaster somewhere down the line.

Make sure that you add the proper stub tower on top of the Rohn tower. Many of today's small turbines are high speed devices that are mounted on pipes. They need sufficient tower clearance because the blades are very thin and flexible. If the machine is supposed to mount on a pipe and you instead bolt it directly on top of either the 25G or 45G, you may discover one day that the blades have struck the tower and shortened themselves.

Finally, as Ian mentioned, the guy radius can run from 40 to 80 percent of the tower height. If space is limited, shorten the guy radius. But if your space won't accommodate the minimum 40 percent guy radius, you need to consider a free standing tower, or reconsider your plans for wind power.

The amount of concrete generally specified for the anchors for the 25G and 45G is actually for a 75 percent radius. If you choke up on the radius, add more concrete to what is specified. By the time you get to 40 percent, I'd probably recommend 2.5 times the concrete specified at 75 percent. Concrete is cheap compared to replacing a wind generator and tower that were not adequately anchored in the first place. Mick Sagrillo

Building a Charge Controller

Dear Richard, I am a recent subscriber to *Home Power*. I have a 64 watt panel charging two golf cart batteries. I would like to charge an automotive battery and an assortment of NiCds off this panel.

This panel is marginal for my needs, so efficiency and cost is important. I would like to avoid using inverters. Can I use multiple charge controllers? Do you sell plans for building charge controllers? Do you have an index available for back issues of *Home Power*? Thanks, Pat Jacobson, Pavillion, WY

Hello Pat. Homebrew charge controller info is posted on our Web site (www.homepower.com). It's free for the download. This is usually a cheap and easy electronics project. There are also several articles on this sprinkled through our CD-ROMs.

And yes, you can use multiple charge controllers. Here at Funky Mountain Institute, we have too many PVs (too much current) for just one charge controller. We use two Heliotrope CC-120E units. Another reason to use multiple charge controllers is when one is a shunt diversion type and the other is a series type, both on the same battery.

For back issues, our CD-ROMs are the way to go. We have three different CDs (Solar2, 3, and 4), which contain all the back issues of *Home Power*, through HP70. All include a search engine (among other goodies like battery and inverter lectures, video clips, and spreadsheets), so you can look up information on any topic easily. Richard Perez



Trojan L-16

**Special Prices for a Limited Time
Delivered Anywhere**

Jesus said, "I am the way, the truth
and the life..." John 14:6



Maple State Battery
(802) 467-3662





CA Lic. #661052

Our 16th Year Offgrid!

**We will meet or beat any other company's prices.
We provide excellent service and technical support.**

Residential Power • Water Systems • Communications
Wind • PV • Hydro • Custom Design • Installation • Mail Order

All Major Brands

SIEMENS



SunFrost



**California Rebates!
(559) 877-7080**



e-mail: ofln@aol.com

http://www.psnw.com/~ofln

located in the central Sierra, near Yosemite



OFFLINE
P.O. Box 231
North Fork, CA
93643

**CATALOG
AVAILABLE**

CHANGE THE WORLD

Affordable On-Grid Solar Electricity

- ASE module with integrated 250-watt Advanced Energy utility-tie inverter
- Simple installation - no dc wiring, just connect to your load center
- Affordable - start with one, expand in the future without rewiring
- PC monitoring card option
- UL listed, American made



With our partner, Advanced Energy Systems, we offer you the tools to change the world, wherever you live, on-grid or off. Visit us at www.solarvt.com or www.advancedenergy.com

SOLAR WORKS, INC.

64 Main Street, Montpelier, VT 05602
Tel: (802) 223-7804 Fax: (802) 223-8980

NEVER BE POWERLESS AGAIN!

RENEWABLE ENERGY SOLUTIONS

- Wind Power
- Microhydro
- Solar
- Independent Power Systems

HUMAN POWERED GENERATOR

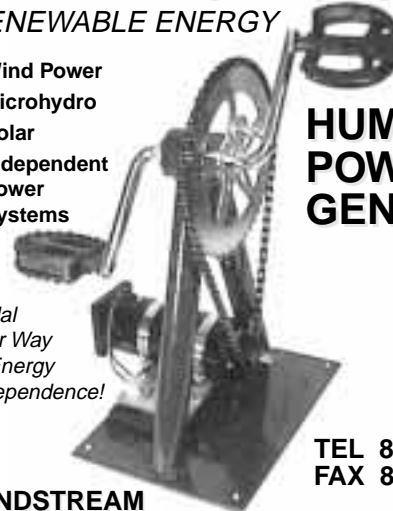

*Pedal
Your Way
to Energy
Independence!*

**Easy to Use
Economical
Dependable
Fun!**

**WINDSTREAM
POWER SYSTEMS INC.**

PO Box 1604 HP, Burlington, VT 05402
25 Years in Business

TEL 802-658-0075
FAX 802-658-1098

e-mail: info@windstreampower.com

website: www.windstreampower.com

Lake Superior Renewable Energy

A.D. & P.C. Jasmin, Proprietors - A. Durst, Associate

Wind Generators • Towers • Batteries
Charge Controllers • Inverters • Backup Generators
Battery Chargers • Site Evaluation
Complete Systems Troubleshooting and Repair Service
Surplus Military & Computer Grade Electronics

We also do: Custom Computer Building / Upgrading / Networking
Custom and Classic Motorcycle Electrical System Rewiring

819 Maple Grove Rd., Duluth, MN 55811
(218) 722-6749

e-mail: slakjaw@aol.com • web: <http://members.tripod.com/~LSRE>

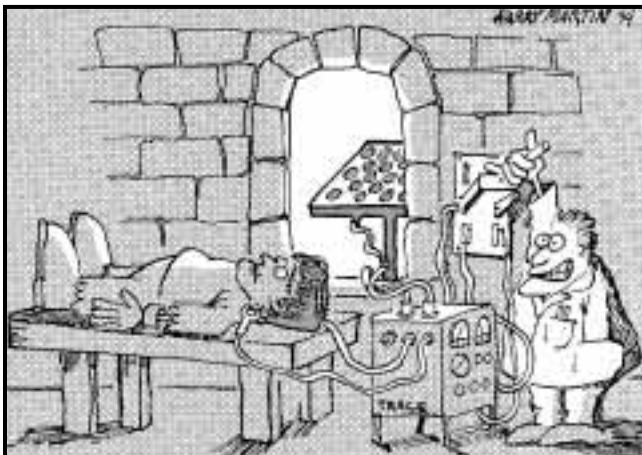

Need a renewable energy quick-start for the ole' brain?

Home Power Quick-Start Subscription Special

our last six available issues, plus a one year surface
subscription...all for \$45 inside USA
(Call for International Rates)

Home Power Magazine
P.O. Box 520, Ashland OR 97520 USA

800-707-6585 in USA, or 541-512-0201

VISA or MC



Richard Perez

©1999 Richard Perez

Global Warming

I'm not much into publishing gloom and doom information in *Home Power*. I figure that there are many publications out there that will tell you about how bad our environment is getting to be and exactly how it got that way. I want to stress *solutions* to our energy-related environmental problems—things we can personally do to make this planet a better place for coming generations. We're talking solar energy, wind energy, and the efficient use of all energy.

I recently read a book by Ross Gelbspan entitled *The Heat Is On*. This book drove home to me the immediacy of global warming. We have to do something, and we have to do it quickly. We need to cut our carbon emissions by half within the next few years, and we need to do this globally. Gelbspan's book clearly documents that big coal and big oil will not be of any help. They have already spent millions to convince us that global warming is not real. And this in the face of a worldwide scientific consensus that global warming is indeed real and a death threat to our planet...

Our atmosphere is really very small and delicate. While it surrounds the whole globe, it is only a few miles thick. Imagine a coat of spray paint on a basketball and you will have an idea of the size relationship between our atmosphere and the planet. Reputable scientists worldwide now recognize that we are burning far too much carbon and that this is resulting in global climate change.

The key feature here is that we must stop burning carbon. Governments and most big corporations have been—and will be—of no help to us. They are into business as usual, and that means putting billions of tons of carbon into our atmosphere yearly. We are going to have to change our energy habits and sources. We need to conserve energy immediately. We need to use renewable sources of energy immediately.

We have to make our politicians know that we are not going to accept business as usual because it threatens the lives of the people on the planet. We need to export renewable energy technologies to developing nations that are on the verge of a carbon binge. We have a big job before us and only a short time to accomplish it. Only we, one at a time, can reverse the effects of a century-long, carbon feeding frenzy. Welcome to the sinking ship—it's time to man the pumps...

Oregon's Net Metering Law

Well, the old saying goes, "Half a loaf is better than none." What I'm trying to figure out is which half of the loaf we got with Oregon's net metering law. I think maybe it's the short half that's mostly moldy.

Oregon's law does make advances in interconnection of small-scale RE systems to Oregon's grid—no megabucks insurance policies, and no gold-plated disconnects. But it is not really a net metering law, since it also allows utilities to choose to pay RE producers only "avoided generating cost," which is less than two cents per kilowatt-hour. In terms of net metering bills nationwide, Oregon's is one of the weakest and most compromised. And to think we were the first state in this nation to pass a bottle bill!

What happened? Well, we got blindsided by Oregon's rural electric cooperatives and also by Idaho Power, a large investor-owned utility, which managed to get itself exempted from the bill entirely (nice bit of work, that). We underestimated our opponents, companies who have the best political pressure that money can buy.

We learned some valuable political lessons, and we'll be back when Oregon's legislature sits again in two years. Next time, we'll be seeking a rate-based incentives bill. Rate-based incentives mean that we are paid more than retail rate for our small-scale renewable energy because it is better than dirty grid power. Ashland, Oregon is doing this now, as are cities in Germany, Switzerland, and Holland.

But all the discussion of state net metering bills may soon be moot since there are plans afoot to introduce a national net metering bill in the U.S. Congress. Meanwhile, we need to keep up the pressure on the state and local levels. If anyone reading this is into enacting RE legislation in your state, please email me. I'd be happy to share what we've learned.

Renewable Energy Fairs

The *HP* crew had a fine time at the SolWest RE Fair in John Day, Oregon last month. Please see my report on SolWest in this issue. It was a proud day for all of us to see such a fine energy fair in our home state.

I want to encourage you all to attend the many energy fairs around the nation—and to start one in your own neighborhood. We need to spread the word about what renewable energy can do. We need to meet each other and get organized. If you have energy fair plans in your neighborhood, please contact me—perhaps *Home Power* can help.

Guerrilla Activity

What I thought was an isolated phenomenon is turning out to be everywhere. I often meet solar guerrillas through the mail. Every time we go to an energy fair, I meet several more solar guerrillas. They seem to be everywhere. What I thought were a few small systems using a couple of modules and Micro Sine inverters are turning out to be hundreds of systems with large PV arrays and even wind generators.

Let's face it, the issue of putting independently produced RE on the grid is a control issue. Utilities want to hang on to their monopolies. If the utilities truly cared about our environment more than their bottom line, then they would welcome our RE on their grid. Instead, they attempt to block us at every turn. Well, so be it. They will have to contend with the solar guerrillas!

Me and My Air Conditioner

Last fall we installed yet another array here at Funky Mountain Institute. This array, consisting of sixteen BP 590 PV modules on a Wattsun dual axis tracker, has become known locally as "Godzilla the PV." We installed this new array to increase our PV power during the winter doldrums, which it most certainly did. I never really considered what would happen during the summer, when we are fat on sunshine. This is an energy source you don't want to turn your back on. On most summer days, our system is now fully recharged by 10 AM sun time.

For years we've been using a swamp cooler to keep the computers cool enough to function during the hot summer days. When it was obvious that we had a significant summertime energy surplus, I decided it was time to install an air conditioner in the office. Joe Schwartz surveyed all the available small room-sized air conditioners and picked a winner—a Sharp model AF-500X. This air conditioner consumes 660 watts and has a power factor of 0.95 according to our Brand AC power meter. Even when it is operating, we are still producing slightly more energy than we can store or consume on a sunny day.

All this has led me to reconsider the concept of conservation. In a stand-alone system, the only way to waste renewable energy is not to use it. When the battery is full, the garden is watered, the water tanks are full, and all the washing is done, I switch on the air

conditioner, and the computers and I cruise through the rest of the day in cool comfort. Homesteading off-grid with solar energy is really tough!

On the Road at SEI

Karen and I just got back from Solar Energy International in Carbondale, Colorado. For the third year in a row, we taught a *Successful Solar Businesses* seminar. Out of the two previous workshops, we have seen one student in six start a working and successful solar business within a year of attending the workshop. This year's workshop was the biggest ever, with over 30 students. These folks were more than qualified—we had two NASA EEs and seven folks who had already run their own businesses.

Those of you considering starting an RE business should attend these workshops. It will be a year before the next one at SEI, but if you need info on starting a solar business immediately, please email me. I have an outline of this course which could help you with your business. While this outline doesn't contain the full course material, it can still be very useful to a budding solar business.

This planet needs a worldwide network of trained and competent RE dealers and installers. These folks are on the front lines of our transition from fossil fuels to clean, renewable sources of energy. If you want to serve as a renewable energy grunt, I will do all I can to assist you. Go solar and take your neighbors with you!

Access

Richard Perez, Home Power, PO Box 520, Ashland, OR 97520 • 530-475-3179 • Fax: 530-475-0836
richard.perez@homepower.com
www.homepower.com



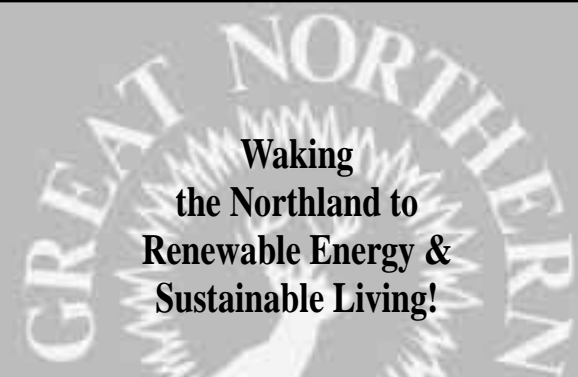

**Waking
the Northland to
Renewable Energy &
Sustainable Living!**

*Bringing the finest in technology, equipment, and
knowledge to the northern midwest*

GREAT NORTHERN SOLAR
Route 1 Box 71, Port Wing, WI 54865 (715) 774-3374

Writing for Home Power Magazine

Home Power is a user's technical journal. We specialize in hands-on, practical information about small scale renewable energy systems. We try to present technical material in an easy to understand and easy to use format. Here are some guidelines for getting your RE experiences printed in *Home Power*.

Informational Content

Please include all the details! Be specific! We are more interested in specific information than in general information. Write from your direct experience—*Home Power* is hands-on! Articles must be detailed enough so that our readers can actually use the information.

Article Style and Length

Home Power articles can be between 350 and 5,000 words. Length depends on what you have to say. Say it in as few words as possible. We prefer simple declarative sentences which are short (less than fifteen words) and to the point. We like the generous use of subheadings to organize the information. We highly recommend writing from within an outline. Check out articles printed in *Home Power*. After you've studied a few, you will get the feeling of our style. System articles must contain a schematic drawing showing all wiring, a load table, and a cost table. Please send a double spaced, typewritten, or printed copy if possible. If not, please print.

Written Release

If you are writing about someone else's system or project, we require a written release from the owner or other principal before we can consider printing the article. This will help us respect the privacy rights of individuals.

Editing

We reserve the right to edit all articles for accuracy, length, content, and basic English. We will try to do the minimum editing possible. You can help by keeping

your sentences short and simple. We get over three times more articles submitted than we can print. The most useful, specific, and organized get published first.

Photographs

We can work from any photographic print, slide, or negative. We prefer 4 by 6 inch color prints with no fingerprints or scratches. Do not write on the back of your photographs. Please provide a caption and photo credit for each photo.

Line Art

We can work from your camera-ready art, scan your art into our computers, or redraw your art in our computer. We often redraw art from the author's rough sketches. If you wish to submit a computer file of a schematic or other line art, please call or email us first.

Got a Computer?

Send us the text for your article on 3.5 inch computer floppy diskette, either Mac or IBM format. We can also read ZIP disks (either Mac or IBM), and Magneto-Optical disks (128 MB, 230 MB, 1.2 GB and 1.3 GB all Mac only). This saves time and reduces typos. Please also send a hard copy printout of your article. Save all word processor files in "TEXT" or "ASCII TEXT" format. This means removing all word processor formatting and graphics. Use your "Save As Text" option from within your word processor. Please don't just rename the file as "text" because it will still include unreadable (at least to us) word processor formatting.

You can send your article via Internet to richard.perez@homepower.com as an enclosed ASCII TEXT file. If you are sending graphics, or articles with embedded graphics, then use this special email address: rap@snowcrest.net

It is wise to telephone or email ahead of electronic file submission. This is particularly true concerning graphics files. There are many, many, many ducks and they all need to be in a row....

Got any questions? Give us a call Monday through Friday from 9–5 Pacific Time and ask. This saves everyone's time.

Access

Richard Perez, Home Power magazine, PO Box 520,
Ashland, OR 97520 USA • 530-475-3179
Fax: 530-475-0836 (24 hours a day)
richard.perez@homepower.com
www.homepower.com



Q&A

Skimming Effect

I am designing a PV system to run desktop computers for rural schools in Cambodia. When I look at sizing the battery, it seems that there is a "time of day" aspect to battery sizing that I have never seen addressed in technical design courses, manuals, worksheets, etc. Here is the issue: computer use will always be limited to daytime, when the battery is charging from the PV array. Does the battery need to be the same size as one that would be needed to run the computer after sunset (assuming identical hours of use)?

The "skimming effect" (which is an extremely non-technical term that I just made up) occurs when the battery is skimmed of its incoming solar electricity by an operating load. My thought is that, all other factors being equal, the battery that is discharged at night is subject to deeper discharge than the battery that is used during daylight (charging) hours.

For the sake of argument, assume that the sun will shine every day, and that there are good reasons for not having a battery that is bigger than it needs to be. Is there any merit to considering this effect in system design, or should I use traditional battery sizing formulas? Thanks for your help.
Peter Banwell, Khmer Solar
banwell.peter@epamail.epa.gov

Hello Peter. You are correct. In systems with daylight peaking energy consumption, the battery can be greatly undersized, saving you money. A case in point—our system here at Home Power cycles 13 to 15 KWH daily. Only 15 percent of our average daily energy consumption comes out of the battery bank, and that happens at night. The other 85 percent of our energy produced during the day runs our computers. At night we are an average efficient home.

The system still has to contend with cloudy days. A good rule of thumb is to size the battery to last four days (96 hours). But if we sized the battery here for four days of storage, it would have to be three times the size it is now. We get by with a much smaller battery (1,640 AH at 12 VDC) because we use most of the energy directly from the PVs. During cloudy periods, we fall back on the wind generator, and as a last resort, one of two engine generators. Richard Perez

Induction Generators for Wind

Dear HP crew, I just got my HP72 yesterday and was saddened by the news of Bill Haveland's death. The previous issue with his article on using three-phase motors as generators is something that I have been wanting to find for a very long time. I had just started experimenting a couple of months ago and then came Bill's article!

I want to build a windplant with the genny on the ground for easy access, and a three-phase motor would make

reliability a non-issue. I have some ideas on power transfer from top of tower to the ground, and I think a fan-type blade to catch the smallest breeze is the answer. Also, having the genny on the ground saves wire, and brushes on the turntable. I know that efficiencies will drop, but being able to work on it on the ground is important to me. Thank you, Les Milford KB2KNX, Schenevus, NY

Les, there are reasons why others do not build wind machines in the manner you suggest. If you want to work at ground level, this can easily be accomplished with a tilt-up tower. A drive shaft leading down to the ground is a big hassle.

Induction generators have been used on wind machines (especially in Denmark) but most people prefer to use permanent magnet alternators. The main reason is that they are more efficient in light winds because they are directly driven. This is when battery charge is most precious. Reliability is also better with permanent magnet alternators than with induction motors, because there is no need for excitation capacitors and for residual magnetism in the rotor, or for gear box oil changes, etc. If you plan to use the windplant just for heating, then an induction/gearbox combination may be quite appropriate because it is cheaper. Otherwise, the gearbox is probably going to rob your low-wind performance.

A fan-type blade will have good starting torque, and you will need that to turn your gearbox, but the fan will be very slow and therefore you need a bigger gear ratio. There are reasons why most people use two or three blades. They run faster, and are usually more efficient than a big fan, apart from being lighter, and easier to control in storms. Whether they start in small breezes depends on the friction as much as on the number of blades.

*I know of people who have built functional wind machines in the way you suggest, but they involve a large amount of unnecessary engineering, so it is not a popular approach. Have fun anyway! Hugh Piggott, Scoraig Wind Electric, Scoraig, Scotland • +44 1854 633 286
Fax: +44 1854 633 233 • hugh.piggott@enterprise.net
<http://homepages.enterprise.net/hugh0piggott/>*

Les, running a shaft from the wind genny to the bottom of the tower is not a very good idea at all. You add unnecessary moving parts, all of which will need maintenance attention at some time. As Hugh mentioned, the larger problem with the shaft idea is that it adds lots of inertia that will not want to start up in a low wind speed. A few have tried this, but all the folks I know have quickly abandoned the idea.

Using an induction generator with wind is very different than using it with water. An induction generator works best when there is only one variable. With water, the flow can be kept quite constant—only the load varies as you turn appliances on and off (or they turn themselves on and off). You don't have this type of control with the wind, which is continuously varying. As a result, there is a great mismatch between input power and load. While induction generators are used almost exclusively with large wind farm equipment, I know

of only one manufacturer (in France) who has incorporated an induction generator in a home-sized wind system. It works only because the manufacturer has added a very complex and costly blade attachment device that keeps the blades spinning at a fixed rpm.

Finally, incorporating an induction generator with wind means adding a gearbox, which is yet more expense and maintenance. This is why few people turn to induction generators for home-sized wind generators. You'd be far better off looking through the surplus catalogs for a permanent magnet generator for your application.

Fan type rotors are fine for high torque applications like water pumping, but they limit power output in higher winds. Almost all wind generator designs use either two or three blade rotors, again, because they work.

I hope this doesn't disillusion you too much. Get a copy of Hugh Piggott's book, Wind Power Workshop, for more info. Good luck with your project. Mick Sagrillo, Sagrillo Power & Light, E3971 Bluebird Rd., Forestville, WI 54213 • 920-837-7523 msagrillo@itol.com

Peltier Junction Air Conditioning

Dear HP, Having found *Home Power* magazine, I am excited at all the facts presented. Now I know what I will do if I win the lottery. I have been trying in a feeble way to experiment in home power.

I came up with a question not answered by the many books I have collected: what about air conditioning? Has anyone experimented with the units used in electric coolers? NASA developed the solid-state Peltier junction that cools one side of a surface and heats the other.

My guess is that a couple of these units in a home ceiling would cool a small area and the hot side would be in the attic. Heat goes up, and cool goes down. After the morning battery charge, your computer could turn this on. I've read of a few people heating water with spare electricity or charging car batteries. Another person made a chimney with a glass side to the sun to draw air across a swimming pool, through the house, and up the chimney.

I located a source of PV panels cheap. I purchased the last one at \$35 at an electronics place in St. Louis, Missouri. It was 12 by 36 inches, 0.75 amps at 12 volts—a start. I got a smaller one at the same cost for use as a battery maintainer on a camper. If I get more, I'll get a Peltier junction from Herbach and Rademan Co., 16 Roland Ave., Mt. Laurel, NJ 08054-1012. They cost \$24.95, or \$34.95 for a larger one. Thank you. Keep shining. W. Tim Griggs, Stewartville, MO

Hello Tim. The Peltier junction is indeed amazing—electricity into heat and cold in a single step with no moving parts. While they work well in small coolers, there are problems scaling up the technology to cool a room. You'd need hundreds, or possibly thousands of them. They are expensive, and the resulting air conditioner would cost many times more than a conventional model. In terms of energy consumption, there would be only marginal savings over a modern motor/compressor type air conditioner. These Peltier modules consume between 10 and 20 watts. So 50 of them will consume between 500 and 1,000 watts, which is the power consumption range of a modern room-sized air conditioner.

Please see my Ozonal Notes in this issue, where I describe using a small air conditioner on solar power. This air conditioner cost less than US\$170, and at 660 watts, it takes about eight PV modules to run it. We use it as a daytime diversion load.

The person with the cooling tower near his pool has the right idea. Moving heat around is difficult and energy intensive. Put the sun directly to work for you if at all possible. Richard Perez



Helitrope General

b/w on negative

2.3 wide
9.9 high



Home Power MicroAds



Rates: 10¢ per CHARACTER, including spaces and punctuation. \$15 minimum per insertion. Please send a check with your ad. Your cancelled check is your receipt.

Help us prevent fraud! *Home Power* MicroAds from individuals must supply serial number(s) for equipment being sold. Businesses must supply a published phone number(s) and a physical address. If at all possible, please pay for your ad via personal or business check or credit card.

While *Home Power* is doing everything we can to prevent fraud, we can assume no responsibility for items being sold.

PURE CASTILE & VEGETARIAN SOAPS. Handmade in an AE environment. We also have hard to find natural bath & body care products. FREE catalog: SIMMONS HANDCRAFTS 42295 AE, Hwy 36, Bridgeville, CA 95526

HYDROELECTRIC SYSTEMS: Pelton and Crossflow designs, either complete turbines or complete systems. Assistance in site evaluation and equipment selection. Sizes from 100 watts to 5 megawatts. Manufacturing home and commercial size turbines since 1976. Send for a free brochure. Canyon Industries Inc., P.O. Box 574 HP, Deming, WA 98244, 360-592-5552.

XXXXXXXXXXXXXXXXX USED SOLAR MODULES XXXXXXXXXXXX
XXXXXXXXXXXXXXXXX 64 Watts \$319 XXXXXXXXXXXXXXXXXXXX
Used MSX60s \$295, BZ 8 amp pwm controller \$49, Ex 2KW inverter SB, 110 amp charger New \$850, 3000+ watt resistors \$35, new 75 Watt modules \$375. Buy, sell New/Used, Trace, NiCds, refrigerator. Try to match anyone's prices. Call or send S.A.S.E. to Craig Eversole, 10192 Choicena, Hesperia CA 92345 for free flyer. M/C VISA Discover 760-949-0505

The big-box Solar Mart may talk a good game from behind the order desk, but are they actually out there doin' it? VERMONT SOLAR ENGINEERING takes pride in being a reality-based dealer/designer/installer. We know the products because we work with them every day— PV, hydro, wind & domestic hot water, from components to complete systems. So reject the romantic salespeak offered by the volume dealers and give us a call. Thanks! 800-286-1252, 802-863-1202, 863-7908(fax). PO Box 697, Burlington, VT 05402. Our Website contains our installation portfolio and attractive sale pricing—www.vtsolar.com-Visa/MC

I AM A SOLAR WHOLESALER looking for retailers to carry my solar electronic and hobby goods. Phone # (916) 486-4373. Please leave message.

START YOUR OWN TECHNICAL VENTURE! Don Lancaster's newly updated INCREDIBLE SECRET MONEY MACHINE II tells how. We now have autographed copies of the Guru's underground classic for \$18.50, Synergetics Press, Box 809-HP, Thatcher, AZ 85552. (520) 428-4073, VISA/MC.

INTERESTED IN INTENTIONAL COMMUNITY? Communities magazine offers complete, updated listings of intentional communities not found in the Communities Directory. Practical information about forming/joining community — alternative buildings & structures; getting off the grid, legal, financial & land options. Plus Eco-villages, Cohousing, decision-making, conflict resolution, successful communities, children in community, research findings on community living. Quarterly. \$18/yr, \$5/sample. 138-HP Twin Oaks Rd, Louisa, VA 23093. (540) 894-5798.

YOUR ALASKAN SOLAR EXPERTS! Complete source for Alaskan alternative power. ABS Alaskan, 2130 Van Horn Road, Fairbanks, AK 99701 907/452-2002, AK 800/478-7145

NEMO SUBMERSIBLE WELL Pumps feature Flojet pumps enclosed in rubber gasketed all metal cases. Complete units low as \$155. Case Kits just \$50. Free Info Packet— Call 508-627-1319

EARTH-SHELTERED HOMES This definitive manual by noted authority Loren Impson features detailed building instructions for the amazingly affordable and practical Ferro-Cement Dome Home. Only \$15 from Sun Life 71 Holistic Hollow, Mount Ida AR 71957

OVER 23 YEARS IN SOLAR Business. Talmage Solar Engineering, Inc. has served customers from the islands off the coast of Maine to Honduras. We take time to figure out the exact needs of each customer, design and engineer systems that will work and give the best possible price on equipment. Give us a chance to show that our experience will help you build a solar power system that will work. We are always here to give backup support. 18 Stone Rd., Kennebunkport, ME 04046 207-967-5945
E-mail tse@talmagesolar.com website www.talmagesolar.com

RADIO/TELEPHONES FOR Remote Home or Business: Commercial quality, up to 20+ mi, Best Prices. (208-263-9755 PST) Send \$1 cash: KRES, Box 215-HP, Kootenai, ID 83840.

VERMONT PV DEALER. David Palumbo/Independent Power & Light has been installing off-grid systems, and helping do-it-yourselfers (who buy their equipment from him) with free professional design advice for over 10 yrs. Trojan and Surrette batteries. FREE with battery purchase IP&L deep cycle battery instructions. Trace, Solarex, Siemens, and BP at fair prices. Large supply of wire and cable. Beware of "fast buck artist," slick talking, "lowest price anywhere" mail order companies who don't take the time to find out what you really need and can't spend the time on personal support and service. Buy from an honest dealer who knows the products and cares about your success in using them. David's installations are innovative, simple to live with, and successful. And our long following of do-it-yourself customers always come back for more because they can rely on getting straight talk, no BS, and the best service possible. "David is one of the original RE pioneers... he knows how to really squeeze all the energy out of a KWH!" Richard Perez (HP60). I P & L, 462 Solar Way Drive, Hyde Park, Vermont 05655. Call David Palumbo 802-888-7194. Email: indeppower@aol.com. Web site: INDEPENDENT-POWER.COM. No catalog requests please. Please call for appointment before visiting.

FOR SALE: Photocopied reprints of *Home Power* issues 1–10 available. All proceeds will be donated to IRENEW. Call 815-469-5334 or e-mail Jeff_Green@msn.com. Sold only in sets of 1 thru 10 for \$30 which includes shipping in most cases.

EDUCATIONAL WINDMILL Kit. Only 8 inches tall, really produces electricity from a PM alternator you build! Add on kit teaches AC/DC conversion concepts. Perfect for Science Fairs, home schools, or adult hobbyists. Grade 5 to adult. Available only at www.picoturbine.com

DIRECT TO YOU SALE!!!! (no pickups on these items) Servel by Dometic 8.0 cu. ft. propane fridge \$1,049; Surrette Solar batteries (5 & 7 yr. warranty): CH-375-L16(6v, 375 ahr.), \$189; T-12-250(12v, 250 ahr.), \$239; Trojan T-105, \$65; all items freight extra. New Bogart Tri-metric meter \$169 delivered. VT Solar 1-800-286-1252

VERY LOW PRICES Solar Electric & Thermal Equip. Panels-Inverters, Charge regulators, wind generators-pumps-controls Please Call (888) 817-1737 or write to 6 Cresta Cir. #7, San Rafael, CA 94903

EDTA RESTORES SULFATED Batteries. EDTA tetrasodium salt, info, catalog, \$12/lb plus \$3.50 ship & handle. Trailhead Supply 325 E. 1165 N. Orem, UT 84057
http://www.webspawner.com/users/trailheadsupply e-mail: trailheadsupply@webtv.net

ALTERNATIVE ENERGY Electrical System in excellent condition, contains the following: Trace Model #U2512SB, 12 volt DC, inverter & battery charger: Trace Model #T220-240 Volt AC Transformer: Trace Model # RC200 Remote Control; Trace Model # 30 amp Controller; 645 amp hour nickel cadmium battery bank; Battery disconnect switch - \$5,700. Call Oakridge Alternative Energy at 802-674-9236

STEAM ENGINE KIT, all materials with machining drawings. Power small boat, generator, or machinery. Information; 55¢ stamp to Pearl Engine Co, RR1 Box 45 Sutton VT 05867, 802-467-3205
<http://homepages.together.net/~pearleng>

LOW HEAD HYDROELECTRIC Plant on 65 acres in South Dakota. 100 kva & 250 kva generators. Some work needed. \$125,000 obo. 805-983-1072. kd6gw@aol.com

HUGH PIGGOTT'S Windmill Workshop video. Take a tour of the workshop of the most famous homebrew wind turbine designer in the world. Learn his tools, tips, and techniques for homebrew wind power. \$28, free USA shipping. Available only at www.picoturbine.com

SOLAR POWER OF TEXAS. For the installation of complete solar systems we cover the entire state. We can deliver any home power equipment that's related to the industry. We offer Solarex MST 43 watt modules at 2.57 Amp 12 Volt for \$185 each when you purchase ten or more. We have many other great bargains. For more information you can reach us at 7711 Colony Rd. Tolar TX 76476 or 800-474-1160 or email gaf@itexas.net. You can also visit us at our Web site at www2.itexas.net/gaf/

FREE-ENERGY Video. Must see. \$35. 800-401-9492, PO Box 2355, Elk Grove, CA 95759

HUGH PIGGOTT'S Windpower Workshop book will teach you how to build a wind turbine. No other book like it. Hugh Piggott's Breakdrum Windmill Plans booklet are complete plans for making a wind turbine out of a junked van breakdrum. Built all over the world, proven design. Available in the USA only from www.picoturbine.com

FREE PROPERTY LIST for mountain land, some with creek or river frontage in beautiful Scott Valley, Northern California just 15 minutes west of Yreka off I-5. 5 to 320 acre parcels, perfect area for retirement or country lifestyle. Call Scott Valley Real Estate (530) 468-2252, www.svre.com

WANTED: The Midwest Renewable Energy Association is in need of two wind generator towers. We'd like Rohn SSV towers, one at 90' to 100', and the other at 110' to 120'. Donations always accepted. Please call Mick at 920-837-7523 or Katy at 715-592-6595.

EMPLOYMENT OPPORTUNITY with E.C.S. — the South's largest solar contractor: solar electric, solar hot water, and solar pool heating. Technical field installer needed. Send or Fax resume to E.C.S. at 6120 SW 13th Street, Gainesville, FL 32608. Fax 352-338-0056.

DIESEL/BIODIESEL Generators 4.5-7KW w/Yanmar engines: durable water-cooled (cogeneration) safe & very economical \$1650 & up. 814-724-7736

WWW.PICOTURBINE.COM is your DIY renewable energy superstore! Free plans, discount books and videos, inexpensive kits for homebrew and education. There is no other web site like it! Build your own wind turbine, solar cell, solar cooker, fuel cell, or EV!

BELL SYSTEM 2.2 volt batteries KS 20472 1680 amp hrs at 8 hr rate 12 @ \$100 each Berryville, Ark. 501-253-7753

NEW ENGINEERING Tools to help with your calculations! Engineering Software Phone/FAX: (301) 540-3605
<http://members.aol.com/engware>

1980 JACOBS 10KW Wind turbine stub tower. Complete with blades, Mastermind Frequency Changer inverter. This is an original first generation machine from the Jacobs Wind Electric Company. \$5000 50 ft Rohn free standing CB tower. Had Whisper 1000 on it. \$400 Call 319-242-6306

MEASURE THE SUN'S Energy! D.I.Y. BTU per Sq Ft per Hour (BSH) or Watts per Sq Meter (WMM). Two simple items available on open market today, less than \$25.00. No batteries, few ounces. Can be used to determine Solar Efficiency (SE) of Solar Water Heaters or PV Panels. Instructions: \$25.00. Carroll Hampleman. 12VDC SunTracking, 204 Pinellas St. Lakeland, FL 33803-4832. 941-619-7412 Free info. E-Mail: cdhampleman@juno.com

Y2K DREAM. Newer 3 bdm, 2 ba home + workshop + 2 car-carport + full solar system on 72 Acres of lush grass and forest land. Good road + telephone + satellite TV. Ranches surround. No neighbors. One hour to Albuquerque. \$195,000 Firm. 505 847 2361.

SECOND HAND 48v forklift battery: 30"x38"x27"high; 3500 lbs. Best offer. kyburg@redsuspenders.com

SOUTH CENTRAL VIRGINIA—Nice partially renovated home on 28 beautiful Ac, strong stream, dam, 20' head, 1kw potential, old mill and other buildings, privacy, super gardening. \$155,000 (804) 248-9205 jp@nurser.com

USED 10KW Bergey Wind Gen w/80' tilt up tower & cables \$12,500 OBO 414-646-4664

PLZ HELP ME! I'd like to work as a PV/RE Installer/Maintainer when I retire from the Air Force in 3 yrs. I want to prepare while stationed here in the UK. I'm looking for donations of new/used textbooks/workshop training manuals. Also donations of used/inop/obsolete hardware/accessories/equipment for hands on familiarization. E-mail dnsnorris@hotmail.com Address PSC37 Box 1004 APO AE 09459. Jesus is Lord.

XXXXXXXXXXXXXXXXXX LP GAS FRIDGES
 XXXXXXXXXXXXXXXXXXXX DANBY 7.8 cu ft. \$899 (LP only), Servel Americana 7.8 cu. ft. (LP, 120 vac and 12 vdc), Conserv Freezer 7.5 cu. ft. (120 vac), Sun Mar Excel NE toilet \$899. Call 1-877-222-4990 (toll free)

UNUSED WINCO 20 KW 3-phase alternator. \$2500 or best offer. kyburg@redsuspenders.com

SOLAREX MSX-60 \$297, 83 \$410, 120 \$595. US Battery 2200 6V@225AH \$54, L16HC@415AH \$148, \$10 premium on single PV or bat. Air 403 \$525. Conserve RF \$995, Fr \$598. Servel RG400 \$999, Frostek LP 8.5 Fr. \$1750. Reconditioned ElecTraks & attachments Info \$2. Call 'til 10:30PM ET for any A.E. need. 717-677-6721 V. Bream, 1755 Coon Rd., Aspers, PA 17304.

UNUSED JACOBS 10 KW Mastermind line interconnect inverter 120/240 VAC output, with choke. \$3000 or best offer. kyburg@redsuspenders.com

WE ARE CURRENTLY increasing our staff and are looking for talented and enthusiastic candidates who would like to apply their expertise in the renewable energy field. Northern Power Systems offers a competitive compensation plan, and is an equal opportunity employer. Northern Power Systems One North Wind Road, PO Box 999, Waitsfield VT 05673-0999. USA TEL (802) 496-2955. FAX (802) 496-2953 <http://www.northernpower.com>

XXXXXXXXXXXXXXXXXX Air 403 \$499 XXXXXXXXXXXXXXXXXXXX
 World Power Technologies WPT 900 \$1599, WPT 1000 \$2489, WPT 3000 \$4889. Call 1-877-222-4990 (toll free)

BEST INVERTERS: 5KW (\$200 or best offer) and 10 KW (\$400 or best offer). kyburg@redsuspenders.com

1993 WHISPER 1000 Never used. New in box, org. bolts, perfect blades w /manual. Available today. \$2,000. Towers (320)240-8421 beco@cloudnet.com

ELECTRIC POWER YOUR BICYCLE. Henthorn Regenerative Electric Auto. Simple Homemade Hydrogen. Plans catalog \$1. DWFrench, POB 2010(AEHP), Sparks, NV 89432

XXXXXXXXXXXX\$3.99/Watt Photowatt 100 Watt \$399XXXXXXXXXXXX
 Photowatt 75 watt \$319, Photowatt 49 watt \$225, UniSolar US64 \$299, AstroPower 120 watt \$599. Call 1-877-222-4990 (toll free)

Y2K SPECIALS: Now offering the worlds Lowest prices Save 5%-50% off marked down prices. From solar modules to inverters to accessories on all top name brands such as Trace, Heart Interface, UniSolar, Siemens, Statpower, Kyocera and Whisper to name a few. Call toll free 877-246-8217 M/C Visa. Visit our website www.solartech2000.com

PROJECT MANAGER Needed at growing construction & renewable energy company. Experienced builder will lead crew building custom log homes, additions & alternative structures, as well as help develop a solar & wind energy business. Shareholding options. Located near hilly, progressive Athens, Ohio. Experience in renewables, marketing & teamwork helpful. Send resume to: Dovetail Construction, 10760 Hooper Ridge, Glouster Ohio 45732, or email: job@dovetailsolar.com

WANTED: Steamco Solar SPM 2000 meter (featured in *HP27: Things That Work!*) new or used in working condition or any information on where to obtain one. 312-738-3776.

XXXXXXXXXXXXXXXXXXXX Trace SW4024 \$2,259XXXXXXXXXXXXXXXXXXXX DR 3624 \$1099, DR2424 & DR 2412 \$899, DR1524 & DR 1512 \$699, PP-SW4024/S \$3299, PP-SW 4024/D \$5699, Trace C40 \$143. Call 1-877-222-4990 (toll free)

NORTHERN POWER SYSTEMS sells, designs, and installs renewable-based power systems worldwide. We are currently increasing our staff and are looking for talented, enthusiastic candidates who would like to apply their expertise in the renewable energy field. We offer a competitive compensation plan, and are an equal opportunity employer. If you are interested in this position, please email Kyle Ellis at kellis@northernpower.com or call Kyle at (802) 496-2955, Extension 35.

FRIENDLY WOOL MACHINES! Non-itchy Llama fiber, turn weeds into Apparel. \$800 Young male, \$1200 Trail Pro, \$1800 Breed Female, \$7200 Female 1998 Grand Champion! Fur sample \$5, Cottonwood Ranch 1111 Hwy 339, Yerington NV 89447. Micro Camels, Soft, Warm and Fuzzy

SOLAR BATTERY CHARGERS. Don't replace dead batteries, recharge them! Place this environmentally friendly unit in the sun to charge AA, AAA, C, D and Prismatic/Gum batteries. Polycarbonate, weather-resistant casing has built-in blocking diode to prevent reverse flow of electricity at night. Attached meter indicates rate of charge. Be prepared for power outages and save thousands on the cost of replacing batteries. Just \$35 each, plus shipping. Y2K SMART, P.O. Box 421751, Kissimmee, FL 34742-1751. Phone 1-888-925-7627.

FEMALE PARTNER WANTED semi retired inventor type with shallow roots in the north east seeks companion interested in sustainable development to go off grid with. Would like to get acquainted via email. jgm@netsync.net

FIVE FOOT HIGH Nuclear Submarine Batteries are very conservatively designed to outlast the lifetime of a submarine boat (35 years). One of the great improvements is the use of calcium in the very thick oxide-lead positive plate. This allows low gassing during charging which results in only adding water once every two years, and much lower charge loss, due to charge migration during standby. We estimate for home use you will get 50 years or better with good care. Each cell can provide 15,400 watts per hour! A 12 volt system = 6 cells x 15,400 watts = 92,400 watt hours!! 2.2 volts per cell; 7000 amp hrs. When power is drawn from batteries at 200 amperes or less instead of 7000 amp-hours as above, kilowatt-hour ratings are increased 20 to 30%. This is due to the lower heating effect of the acid. Operating batteries at room temperature increases the efficiency still more. Using the electrolyte bubbling system built into the cells increases the efficiency still more. These batteries were made by Exide, one of the leaders of battery manufacturing. Weight 1068 lbs. with acid; 900 lbs. dry; 14" x 14" x 5 ft. high; fiberglass case for extra strength; 22 gal. ordinary auto battery acid (available in most cities for \$1.50 per gal.); all new cells shipped dry on pallets \$3,000 per cell, FOB Brockton MA. Will run average house for 6 months between charges. Can be trickle charged from commercial power, wind generators, or photovoltaic. You will find the quiet power of batteries is far better for peace of mind than a noisy generator that has to be serviced & fueled regularly. Be prepared for the Y2K problem in the year 2000 when many power companies will experience microprocessor and computer problems in managing the national grid system. Can your business handle a 2 or 3 week power outage? Is it worth the gamble? Why deal with small batteries with short lifetimes, replace the weak link in photovoltaic systems with true lifetime submarine battery cells! 508-588-5246

I HAVE "ONE" 10 KW Jacobs Smooth case with 70' Rohn tower. 21' ft wood blades. Utility inverter or offgrid + tax + ship Price starts \$9000 Palouse Wind & Water 208-883-3676



Adopt a Library!

When Karen and I were living with kerosene lamps, we went to our local public library to find out if there was a better way to light up our nights. We found nothing about small scale renewable energy.

One of the first things we did when we started publishing this magazine twelve years ago was to give a subscription to our local public library.

You may want to do the same for your local public library. We'll split the cost (50/50) of the sub with you if you do. You pay \$11.25 and Home Power will pay the rest. If your public library is outside of the USA, then we'll split the sub to your location so call for rates.

Please check with your public library before sending them a sub. Some rural libraries may not have space, so check with your librarian before adopting your local public library. Sorry, but libraries which restrict access are not eligible for this Adopt a Library deal—the library must give free public access. — Richard Perez

To Adopt a Library write or call

Home Power®

PO Box 520, Ashland, OR 97520 USA
1-800-707-6585 or 541-512-0201 or FAX 541-512-0343
hp@homepower.com • www.homepower.com



Index to Advertisers

- aatec publications — 92
Abraham Solar Equipment — 104
Adopt a Library — 143
Advanced Composting Systems — 123
Alternative Energy Engineering — 69
Alternative Energy Systems Co — 36
Alternative Solar Products — 26
American Solar Energy Society — 86
AstroPower — 53
BackHome — 126
Backwards to the Future — 71
Backwoods Solar Electric Systems — 73
Bell Solar International Inc — 123
Bergey Windpower — 15, 51, & 63
Bogart Engineering — 105
Bornay — 82
Bowers Power Systems — 104
BP Solar — 2, 3, & 27
Brand Electronics — 56
BZ Products — 118
C. Crane Company — 126
C.C. Solar Technologies — 90
Canrom Photovoltaics Inc — 78
China Diesel — 61
Cottonwood Ranch — 121
Creative Energy Tech — 105
Dankoff Solar Products — 77
Delivered Solutions — IBC
Dyno Battery — 46
Eklektix — 126
Electro Automotive — 92 & 123
Electron Connection — 87
Energy Conservation Services — 72
Energy Outfitters — 118
Energy Systems & Design — 113
Environmental Marketing Inc — 83
EPOWER — 109
ETA Engineering Inc — 112
Exeltech — 67
Feather River Solar Electric — 35
FireWind&Rain — 62
GenSun Integrated Solar Electric Systems — 78
Global Power Systems — 101
Great Northern Solar — 137
Greenshelf — 119
Guerrilla Solar T-shirts — 83
Harris Hydroelectric — 109
Heart Interface — 1
Heaven's Flame — 83
Heliotrope General — 140
Hitney Solar Products — 105
Home Power Back Issues — 127
Home Power Biz Page — 81
Home Power CD-ROMs — 80
Home Power Sub Form — 80
Home Power T-shirts — 98
Horizon Industries — 119
Hot Products Inc — 126
Hydrocap — 113
Intermountain Solar Technologies — 79
International Carbon Bank & Exchange — 126
Jack Rabbit Energy Systems — 90
KTA Services Inc — 108
Kyocera Solar Inc — OBC
Lake Superior Renewable Energy — 135
Low Keep Refrigeration — 109
Maple State Battery — 134
Morningstar — 14
MREA Workshops — 80
Natural Energy Systems — 123
New Electric Vehicles — 99
New England Solar Electric Inc — 113
New England Solar Homes — 23
Newinli International Inc — 72
Northern Arizona Wind & Sun — 101
Northwest Energy Storage — 57
Offline — 135
Palouse Wind & Water — 118
Planetary Systems — 78
Quick Start REading Special — 135
RAE Storage Batteries — 121
RCH Fan Works — 112
Real Goods — 85
Refrigeration Parts Solution — 119
Renewable Energy Videos — 82
Rolls Battery Engineering — 79
RV Power Products — 83
Sensible Steam — 126
Siemens Solar Industries — 25
Simmons Handcrafts — 126
Simpler Solar Systems — 35
Snorkel Stove Company — 113
Solar Converters Inc — 118
Solar Depot — IFC
Solar Electric Inc — 100
Solar Energy International — 91
Solar On Sale — 99 & 119
Solar Pathfinder — 119
Solar Plexus — 82
Solar Village Institute — 85
Solar Webb Inc — 112
Solar Works Inc — 135
Solarex — 47
SolarRoofs.com — 118
SolarSense.com — 7
Solec — 37
Soltek — 117
Southwest Windpower — 52 & 108
Spectacle Technology — 111
Sun Frost — 82
SunAmp Power Company — 93
Sunelco — 16
Sunlight Energy Corp — 85
SunLine Solar — 109
Sunweaver — 90
SunWize — 93
Surrette Battery Company Ltd — 68
Toronto Surplus & Scientific — 73
Trace Engineering — 17
Tractel Inc — 108
Trojan — 44
Tumbler Tech — 93
Two Seas Metalworks — 45
U.S. Battery — 24
Vanner Power Systems — 68
Vermont Solar Engineering — 92
Wattsun (Array Tech Inc) — 117
Windstream Power Systems Inc — 135
World Power Technologies — 23
Zomeworks — 112





HOME POWER

THE HANDS-ON JOURNAL OF HOME-MADE POWER

ISSUE #73

October / November 1999

\$4.75 U.S.

\$7.00 CAN.

Display until December 1

Sell Solar to the Power Company

Community Wind Power

Electric Bicycle Conversion

SolWest Energy Fair



***Neighborhood
Solar Workshop***

WHAT DO YOU WANT?

- Pre-Packaged Solar Electric Systems
- Easy-To-Install, Hassle-Free Systems
- Great Prices
- Engineered & Partially Pre-assembled
- Code Compliant Systems
- Easy-to-follow Installation Manual
- Technical Assistance Provided
- Owner-Builder Discounts



- PV Panels
- Batteries
- Regulators
- Inverters
- Switchgear
- Wind Generators
- Solar Water Heaters

WE FIGURED YOU WOULD!

SO WE MADE:



- Utility-Connected Models
- Off-Grid, Stand-Alone Models
- Hybrid Models with Wind or Hydro



ATTRACTIVE DEALER DISCOUNTS



Checkout our on-line catalog at
www.solardepot.com/pvcatalog/index.html



WE ARE



Solar-Depot-San Rafael
61 Paul Drive
San Rafael, CA, 94903

email staff@solardepot.com

(415) 499-1333

Fax (415) 499-0316

Orderline (800) 822-4041



Solar Depot-Sacramento
8605 Folsom Blvd.
Sacramento, CA, 95826
email soldrpo@calweb.com
(916) 381-0235
Fax (916) 381-2603
Orderline (800) 321-0101



Golden Genesis Company is Proud to Become Kyocera Solar, Inc.

We are NOT an Oil Company ...
We are NOT a Utility ...
BUT WE PROVIDE ENERGY.

Kyocera is a global producer of high technology solutions. Our commitment to solar and other renewable sources of electricity began in 1975 with the creation of Japan Solar Energy Corporation. Since then we have grown to become the World's Largest Manufacturer of solar electric modules, producing 29 megawatts last year.

We believe in solar energy. Our corporate headquarters is powered by more than 200 kilowatts of solar modules and features many integrated systems that are both energy saving and innovative.

As the new millennium approaches, we are strengthening our commitment to preserving the world's resources and broadening the positive impact of solar electricity. To that end, we proudly announce our merger with Golden Genesis Company – a world leading manufacturer and marketer of solar electric systems.

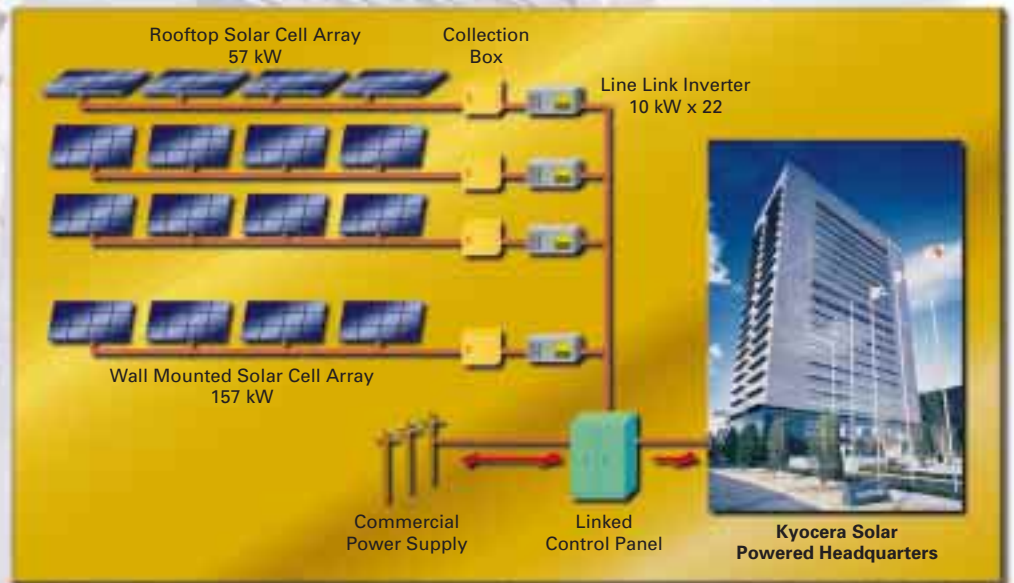

KYOCERA SOLAR, INC.
7812 EAST ACOMA DRIVE
SCOTTSDALE, AZ 85260
480/951-6330
800/544-6466
FAX 480/951-6329
www.kyocerasolar.com



Home Power Subscription

\$22.50 per year (6 issues) to U.S. Zip codes via 2nd Class U.S. Mail
\$36.00 per year (6 issues) to U.S. Zip codes via 1st Class U.S. Mail
\$30.00 (U.S. drawn on U.S. Bank) International Surface Mail, see pg. 81 for Air Rates

Home Power Magazine, PO Box 520, Ashland, OR 97520
Subscriptions: 800-707-6585 (inside USA) or 541-512-0201 or FAX 541-512-0343
Editorial and Advertising: 530-475-3179 or FAX 530-475-0836

To subscribe to Home Power, please fill out the sub form below, enclose payment as a check, money order, or Visa/MasterCard, and mail this form. Tape the form well or use an envelope so your check doesn't fall out. Your sub or renewal will start with HP's next regularly scheduled issue. Please allow up to ten weeks for the start of your 2nd class sub. For those wishing **International Subscriptions or Back Issues of Home Power, please see page 81.**

- New 2nd Class Sub-\$22.50 to USA Zip Codes
- New 1st Class Sub-\$36 to USA Zip Codes
- Sub Renewal Specify 1st or 2nd Class
- Change of Address Include Old Address
- Gift subscription From (give your name and address here) _____

DO YOU WANT US TO SEND YOU A SUBSCRIPTION RENEWAL NOTICE?

The number of the last issue in your subscription is printed on your mailing label.

- Yes, remind me by mail when my subscription runs out.
- No, I'll check my mailing label so we can save energy & paper.



PLEASE CLEARLY PRINT BELOW THE COMPLETE NAME AND ADDRESS FOR THIS SUBSCRIPTION

NAME _____

STREET _____

CITY _____ STATE _____ ZIP _____

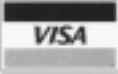
PHONE _____ E-MAIL _____

-  **Credit Card Orders:** please check the type of card you have and fill in the information below.
Signature (as shown on Card) _____ Exp. Date _____
-  Credit Card Number _____ Amount \$ _____

The following information about your renewable energy usage helps us produce a magazine which better serves your interests. This information will be held confidential. We do not sell our mailing list. Completion of the rest of this form is not necessary to receive a subscription, but we would greatly appreciate your input.

NOW: I use renewable energy for (check ones that best describe your situation)

- All electricity
- Most electricity
- Some electricity
- Backup electricity
- Recreational electricity (RVs, boats, camping,)
- Vacation or second home electricity
- Transportation power (electric vehicles)
- Water heating
- Space heating
- Business electricity

In The FUTURE: I plan to use renewable energy for (check ones that best describe your situation)

- All electricity
- Most electricity
- Some electricity
- Backup electricity
- Recreational electricity (RVs, boats, camping,)
- Vacation or second home electricity
- Transportation power (electric vehicles)
- Water heating
- Space heating
- Business electricity

RESOURCES: My site(s) have the following renewable energy resources (check all that apply)

- Solar power
- Wind power
- Hydro power
- Biomass
- Geothermal power
- Tidal power
- Other renewable energy resource (explain)

The GRID: (check all that apply)

- I have the utility grid at my location.
I pay _____¢ for grid electricity (cents per kiloWatt-hour).
_____% of my total electricity is purchased from the grid.
- I sell my excess electricity to the grid.
The grid pays me _____¢ for electricity (cents per KiloWatt-hour).

(continued on reverse)

I now use, or plan to use in the future, the following renewable energy equipment (check all that apply).

NOW	FUTURE		NOW	FUTURE	
<input type="checkbox"/>	<input type="checkbox"/>	Photovoltaic modules	<input type="checkbox"/>	<input type="checkbox"/>	Methane digester
<input type="checkbox"/>	<input type="checkbox"/>	Wind generator	<input type="checkbox"/>	<input type="checkbox"/>	Thermoelectric generator
<input type="checkbox"/>	<input type="checkbox"/>	Hydroelectric generator	<input type="checkbox"/>	<input type="checkbox"/>	Solar oven or cooker
<input type="checkbox"/>	<input type="checkbox"/>	Battery charger	<input type="checkbox"/>	<input type="checkbox"/>	Solar water heater
<input type="checkbox"/>	<input type="checkbox"/>	Instrumentation	<input type="checkbox"/>	<input type="checkbox"/>	Wood-fired water heater
<input type="checkbox"/>	<input type="checkbox"/>	Batteries	<input type="checkbox"/>	<input type="checkbox"/>	Solar space heating system
<input type="checkbox"/>	<input type="checkbox"/>	Inverter	<input type="checkbox"/>	<input type="checkbox"/>	Hydrogen cells (electrolyzers)
<input type="checkbox"/>	<input type="checkbox"/>	Controls	<input type="checkbox"/>	<input type="checkbox"/>	Fuel cells
<input type="checkbox"/>	<input type="checkbox"/>	PV tracker	<input type="checkbox"/>	<input type="checkbox"/>	RE-powered water pump
<input type="checkbox"/>	<input type="checkbox"/>	Engine/generator	<input type="checkbox"/>	<input type="checkbox"/>	Electric vehicle

FOLD HERE AND TAPE EDGES

Please write to us here. Tell us what you like and don't like about Home Power. Tell us what you would like to read about in future issues. Thanks for your attention and support.

Check here if it is OK to print your comments as a letter to Home Power.

FOLD HERE AND TAPE EDGES

Return Address



Home Power Magazine
Post Office Box 520
Ashland, OR 97520